

**CITY  
OF  
COLLINSVILLE**



**INFRASTRUCTURE DESIGN MANUAL  
EFFECTIVE MONTH DAY, YEAR.**



## TABLE OF CONTENTS

Section 1 General Provisions and Requirements.....	1
1.010 Definitions.....	1
1.020 Abbreviations.....	10
1.030 General.....	10
1.040 Utility Coordination.....	10
1.050 Plan Standards .....	11
1.050.01 Survey.....	11
1.050.02 Civil Construction Plan Submittal.....	11
1.060 Notification of Construction .....	20
1.070 Quality Control Testing .....	20
1.080 Inspection.....	21
1.090 As-Built and Record Drawings.....	21
1.090.01 As-Built Plans.....	21
1.090.02 Record Drawings .....	23
1.100 Acceptance of Facilities.....	24
1.100.10 Final Letter of Acceptance .....	24
1.100.20 Warranty .....	25
1.110 Modifications .....	25
1.120 Appeal of City Engineer Order or Decision .....	26
1.130 Revision to these Specifications.....	26
Section 2 Design Requirement for Transportation Facilities .....	27
2.010 Standards for Street Design .....	27
2.010.01 General.....	27
2.010.02 Location and Layout of New Streets .....	27
2.010.03 Circulation Plan and Transportation Impact Analysis Required .....	28
2.010.04 Connectivity .....	33
2.010.05 Private Streets.....	33
2.010.06 Applicability.....	33
2.020 Street Classification and Right-of-Way .....	33
2.020.01 Functional Classification .....	33

## Table of Contents

2.020.02	Cross Sections .....	34
2.020.03	Right-of-Way and Easements.....	35
2.030	Design Criteria.....	37
2.030.01	Desired Operating Levels of Service .....	37
2.030.02	Design Traffic Levels.....	37
2.030.03	Design Vehicle.....	38
2.030.04	Minimum Turning Paths of Design Vehicles .....	38
2.030.05	Design Speed.....	38
2.030.06	Street and Lane Widths.....	42
2.030.07	Special Street Configurations.....	42
2.030.08	Horizontal Alignment .....	46
2.030.09	Vertical Alignment.....	49
2.030.10	Sight Distance.....	52
2.030.11	Lane Transitions .....	54
2.030.12	Auxiliary Lanes .....	54
2.030.13	Intersections .....	54
2.030.14	Sidewalks, Curbs & Gutters, Shoulders and Ditches.....	67
2.030.15	Medians.....	70
2.030.16	On-Street Parking.....	71
2.030.17	Bridges.....	73
2.030.18	Clearance Requirements.....	73
2.030.19	Barriers and Fencing .....	74
2.030.20	Provision for Utilities.....	75
2.030.21	Emergency Access Street Requirements .....	78
2.030.22	Bus Stops.....	79
2.030.23	Access Management & Design.....	80
2.040	Pedestrian Facilities .....	96
2.040.01	ADA Requirements.....	96
2.040.02	Typical Sections.....	96
2.040.03	Managing Access for Pedestrian Safety .....	96
2.040.04	Intersections .....	96
2.040.05	Sidewalk Ramps .....	97

## Table of Contents

2.040.06	Corners.....	97
2.040.07	Crosswalks.....	97
2.040.08	Detectable Warning Surfaces.....	97
2.040.09	Transit Stops.....	98
2.040.10	Grade-Separated Pedestrian Crossings.....	98
2.050	Bicycle Facilities.....	99
2.050.01	Types of Facilities.....	99
2.050.02	Bicycle Shared Streets.....	99
2.050.03	Multi-Use Paths/Greenways.....	100
2.050.04	Bicycle Typical Sections.....	100
2.050.05	Intersections.....	100
2.060	Traffic Calming.....	102
2.060.01	General.....	102
2.060.02	Traffic Calming Techniques.....	102
Section 3 Traditional Neighborhood Development (TND) Street Design.....		112
Section 4 Pavement Design.....		113
4.010	General.....	113
4.010.01	Pavement Thickness.....	113
4.010.02	Pavement Design.....	113
4.010.03	Pavement Type.....	113
4.020	Grading.....	113
4.030	Pavement Construction.....	114
4.030.01	Subgrades.....	114
4.030.02	Subgrade Modification.....	114
4.030.03	Granular Subbase.....	115
4.030.04	Compaction Verification.....	115
4.030.05	Flexible Pavement.....	116
4.030.06	Rigid Pavement.....	118
4.040	Curbing and Sidewalk.....	124
4.040.01	Residential Sidewalks.....	124
4.040.02	Commercial Sidewalks.....	127
4.040.03	Bikeways.....	127

Table of Contents

4.040.04 Handicapped Ramps ..... 128

4.040.05 Curb and Gutter Sections..... 128

4.050 Stamped Concrete and Brick Pavers ..... 129

4.050.01 Stamped Concrete ..... 129

4.050.02 Concrete Unit Pavers ..... 130

4.060 Inspection and Laboratory Testing ..... 130

4.060.01 Testing Frequency..... 131

Section 5 Signal Design ..... 132

5.010 Introduction ..... 132

5.020 Administration ..... 132

5.020.01 Signal Warrants ..... 132

5.020.02 Engineering Study ..... 132

5.020.03 Signal Spacing..... 132

5.020.04 Private Benefit Signals..... 133

5.020.05 Designer Prequalifications ..... 133

5.050.06 Intersection Design Study (IDS)..... 133

5.030 Design Standards..... 134

5.030.01 Referenced Standards..... 134

5.030.02 Design Requirements..... 134

5.030.03 Traffic Signal System Requirements..... 137

5.030.04 Electrical Requirements ..... 137

5.030.05 Construction..... 138

5.030.06 Pedestrian Signals and Timings..... 138

Section 6 Street Lights ..... 140

6.010 Introduction ..... 140

6.020 Ownership/Responsibility..... 140

6.020.01 Responsibilities Delineated..... 140

6.030 Design Guidelines..... 142

6.030.01 General Design Standards..... 142

6.030.02 Local and Private Streets..... 144

6.030.03 Collector and Arterial Streets..... 145

Table of Contents

6.030.04 Submission Requirements (Ameren Illinois or Southwestern Electric Cooperative Owned Streetlights) ..... 147

6.030.05 Submission Requirements (City Owned Street Lights) ..... 148

6.030.06 Light Levels..... 151

6.040 Record Drawings ..... 153

Section 7 Traffic Signs and Markings ..... 155

7.010 Signing ..... 155

7.010.01 Type and Location of Signs..... 155

7.010.02 Design, Installation, and Maintenance ..... 155

7.010.03 Sight Visibility Standards for Traffic Control Signs ..... 155

7.010.04 New Street Signing..... 156

7.010.05 Other Standards ..... 156

7.010.06 Sign Posts, Supports, and Mountings..... 156

7.010.07 Sign Reflectivity ..... 156

7.010.08 Sign Blanks ..... 156

7.020 Pavement Marking and Striping ..... 156

7.020.01 Type and Location of Striping and Markings..... 156

7.020.02 Design, Installation, and Maintenance ..... 157

7.020.03 Crosswalks..... 157

Section 8 Storm Drainage Facilities and Sediment Control ..... 158

8.010 General..... 158

8.020 General Requirements of Storm Sewer Construction ..... 158

8.020.01 Size and Shape ..... 158

8.020.02 Materials ..... 158

8.020.03 Bedding ..... 158

8.020.04 Concrete Pipe or Conduit Strengths ..... 159

8.020.05 Monolithic Structures ..... 159

8.020.06 Alignment..... 159

8.020.06 Location..... 160

8.020.07 Flowline ..... 161

8.020.08 Manholes ..... 161

8.020.09 Overflow/Design System..... 162

Table of Contents

8.030 Stormwater Conveyance Systems Design Criteria ..... 163

    8.030.01 Flow Quantities ..... 163

    8.030.02 Hydraulic Grade Line for Closed Conduits ..... 166

    8.030.03 Hydraulic Grade Line Limits ..... 173

    8.030.04 Inlets..... 174

    8.030.05 Improved Channels ..... 175

    8.030.06 Culverts ..... 184

8.040 Bridges ..... 184

    8.040.01 Waterway Capacity and Backwater Effects ..... 184

    8.040.02 Clearance..... 184

    8.040.03 Waterway Alignment ..... 184

    8.040.04 Erosion Protection..... 184

8.050 Outlet Erosion Protection ..... 185

8.060 Stormwater Management for Development and Redevelopment Projects ..... 185

    8.060.01 Minimization of Increases in Runoff Volumes and Rates ..... 185

    8.060.02 Water Quality and Multiple Uses..... 186

    8.060.03 Design Criteria, Standards, and Methods ..... 187

    8.060.04 Accommodating Flows from Upstream Tributary Areas ..... 197

    8.060.05 Early Completion of Detention Facilities..... 198

8.070 Soil Erosion and Sediment Control ..... 198

    8.070.01 General..... 198

    8.070.02 Erosion and Sediment Control Plan Submittal Requirements ..... 200

    8.070.03 Design and Operation Standards and Requirements ..... 200

    8.070.04 Maintenance of Control Measures ..... 203

8.080 Long Term Maintenance Responsibility..... 204

    8.080.01 Long Term Maintenance Responsibility..... 204

    8.080.02 Inspections and Testing ..... 205

    8.080.03 Specialized Precautions..... 207

    8.080.04 Amendments of Plans ..... 208

    8.080.05 Final Certification ..... 208

Exhibit 8-A..... 209

Section 9 Sanitary Sewer Facilities..... 221



Table of Contents

9.010 General..... 221

9.020 General Requirements of Sanitary Sewer Construction ..... 221

    9.020.01 Size and Shape ..... 221

    9.020.02 Materials ..... 221

    9.020.03 Bedding and Backfill..... 222

    9.020.04 Pipe or Conduit Under Streets and Pavements ..... 222

    9.020.05 Joints ..... 222

    9.020.06 Monolithic Structures ..... 223

    9.020.07 Alignment..... 223

    9.020.08 Location..... 223

    9.020.09 Flowline ..... 224

    9.020.10 Manholes ..... 224

    9.020.11 Sewage Treatment Facilities ..... 226

9.030 Design Requirements ..... 226

    9.030.01 General..... 226

    9.030.02 Gradients..... 226

    9.030.03 Depth and minimum Cover..... 227

    9.030.04 Flow Design ..... 228

    9.030.05 Population Factors ..... 228

    9.030.06 Sanitary Flow Table ..... 229

    9.030.07 Hydraulic Grade Line ..... 229

    9.030.08 Infiltration ..... 235

    9.030.09 Special Situations and Design Requirements..... 235

9.040 Inspection and Testing ..... 239

    9.040.01 Manholes ..... 239

    9.040.02 Flexible Pipe Testing..... 240

Section 10 Water Distribution Facilities..... 241

    10.010 General..... 241

    10.020 General Requirement of Water Main Construction ..... 241

        10.020.01 Size ..... 241

        10.020.02 Materials ..... 241

        10.020.03 Bedding and Backfill ..... 242

## Table of Contents

10.020.04	Pipe Under Streets and Pavements .....	242
10.020.05	Fittings and Valves .....	242
10.020.06	Fire Hydrants .....	243
10.020.07	Location.....	243
10.020.09	Grade.....	244
10.020.10	Protection of Water Supply.....	244
10.020.11	Dead Ends.....	245
10.020.12	Thrust Blocking.....	245
10.020.13	Service Connections .....	246
10.020.14	Hydrostatic Testing .....	246
10.020.15	Disinfection .....	247

## Section 1 General Provisions and Requirements

### 1.010 Definitions

**AASHTO:** American Association of State Highway and Transportation Officials.

**ADA:** Americans with Disabilities Act.

**ADAAG:** Americans with Disabilities Act Accessibility Guidelines.

**Allowable Release Rate:** The pre-development or existing condition peak flow corresponding to a selected rainfall frequency event.

**ANSI:** American National Standards Institute.

**APWA:** American Public Works Association.

**ASTM:** American Society of Testing and Materials (now ASTM International).

**Agreement Guaranteeing Road Improvements:** Same as Escrow, Special.

**Architect:** An Illinois registered professional architect.

**Backfill:** The material used to fill an excavation.

**Base Flood:** The flood having a 1% chance of being equaled or exceeded in any given year. The base flood is also known as the 100-year frequency flood event.

**Basement:** The lowest level or story of a structure, which has its floor below grade on all sides.

**Bedding:** The material on which the pipe or conduit is supported and protected.

**Benchmark:** A definite point of known elevation and location and of more or less permanent character. The identity and elevation shall be based on United State Geological Survey (USGS) Datum.

**BMP:** “Best Management Practices”. Structural and non-structural stormwater management methods designed to improve stormwater quality by meeting pollutant removal goals; to reduce stormwater runoff volume and discharge rate from a site; and, for certain features, to provide a degree of channel protection.

## Section 1 General Provisions and Requirements

**B.O.D.:** “Biochemical Oxygen Demand”; means the quantity of oxygen utilized in 5 days in the biochemical oxidation of carbonaceous and nitrogenous compounds and certain inorganic materials in water or wastewater using procedures in 40 CFR 136 and expressed in milligrams per liter.

**Bridge:** A structure having a clear span greater than 20 feet measured on a horizontal plane along the centerline of the roadway; also a multiple span structure where the total length of spans are in excess of 20 feet. For both single and multiple span bridges, the clear span shall be construed to mean the total distance from stream face to stream face of end bents or outer walls of structure. For multiple pipes, the span shall be construed to mean the total distance measured between the two exterior pipes, provided the clear distance between each pipe is less than one-half the diameter of the pipe.

**Building:** A structure that is affixed to the land, having one or more floors, external walls and a roof.

**Channel:** A natural or artificial water course.

**City:** The City of Collinsville, Illinois.

**City Engineer:** For the purposes of this Manual, the City Engineer of the City of Collinsville, or its designee. In the event there is no City Engineer or designee, then the “City” shall be deemed in its place.

**Community Development Director:** For the purposes of this Manual, the Director of Community Development of the City of Collinsville, or its designee. In the event there is no Director or designee, then the “City” shall be deemed in its place.

**Compensatory Storage:** An artificially excavated, hydraulically equivalent volume of storage within the floodplain used to balance the loss of natural flood storage capacity when fill or structure are placed within the floodplain.

**Construction Cost Index (CCI):** An annual analysis, which measures the effects of wage-rate and material-price trends. The percent change of the construction cost index from December of a given year to December of the following year as published in the Engineering News Record is used to inflate trust fund and traffic generation assessment rates.

**Creep:** The lengthening of concrete pavement due to cycles of contraction and expansion of individual slab sections.

**Culvert:** A closed conduit for the free passage of surface drainage water under a highway, railroad, or other embankment.

**Dedication:** The process by which the owner gives approved sidewalk, street, sanitary sewer, storm sewer, water main, and other facilities to the City for public use and maintenance.

## Section 1 General Provisions and Requirements

**Department:** For the purposes of this Manual, the City of Collinsville Department of Public Works.

**Design Speed:** On existing roadways design speed shall be the 85<sup>th</sup> percentile speed of motorists on the roadway as established by radar studies, or 5 miles per hour (mph) greater than the posted speed limit, whichever is greater. On new roadways, design speed shall be 5 mph greater than the anticipated posted speed limit. For non-residential and residential streets with a pavement width of 32 feet or less, the design speed shall be the anticipated posted speed limit.

**Developed Runoff Rate:** The peak flow corresponding to a selected rainfall event as a result of developed site conditions.

**Development Site:** The specific area of land where regulated activities in the municipality are planned, conducted, or maintained.

**Differential Runoff Rate:** The difference between the pre-developed runoff rate and the developed runoff rate normally using PI factors.

**Differential Volume of Stormwater:** The amount of differential stormwater volume between the pre-developed and developed runoff rates which the detention basin must detain (hold).

**Director:** For the purposes of this Manual, the Director of Public Works of the City of Collinsville, or its designee. In the event there is no Director, then the "City" shall be deemed in its place.

**Drainage Facility:** Any system of artificially constructed drains, including open channels, whether lined or unlined, and storm sewers used to convey storm water, surface water or groundwater. A drainage facility may also convey effluent discharged pursuant to an NPDES permit when such use is approved by the City Engineer.

**Drive, Multi-Family Access:** A private way or driveway which affords a means of vehicular access to parking areas and bays and to abutting building in a multiple dwelling unit subdivision.

**Driveway:** A privately maintained travel way used for vehicular access to a site and distribution within a site, not including sidewalks.

**Driveway, Common (Party):** A single driveway providing vehicular access to two adjoining properties.

**Drop:** A structural configuration where flow falls into a structure from an incoming pipe.

**East-West Gateway Council of Governments (EWG):** The Metropolitan Planning Organization for the St. Louis Region.

**Engineer:** An Illinois registered professional Engineer.

## Section 1 General Provisions and Requirements

**Entrance, Commercial:** A driveway providing ingress and egress for a commercial site.

**Entrance, Residential:** A driveway providing ingress and egress for a residential site.

**FEMA:** Federal Emergency Management Agency.

**Fence, Sight Proof:** A fence with an opaque value of seventy (70) percent or greater.

**Finish Elevation:** The proposed elevation of the land surface of a site after completion of all site preparation work.

**Finished Grade:** The final elevation of the ground surface after development.

**Flood Insurance Floodway Maps:** Current maps from the Federal Emergency Management Agency Flood Insurance Study.

**Flood Insurance Study:** The Official Report proved by the Federal Emergency Management Agency containing flood profiles; flood boundaries; floodway maps and the water surface elevation of the base flood.

**Flood Plain:** A geographical area susceptible to periodic inundation from the overflow of natural waterways during the base (100-year) flood.

**Flood Plain Study:** An engineering analysis to determine the hydraulic effect, if any, of the proposed development to the existing Flood Plain.

**Floodway:** The channel of the river or other watercourse and the adjacent land areas that must be reserved in order to discharge the base flood without cumulatively increasing the water surface elevation more than one foot or so delineated in the Flood Insurance Study.

**Force Main:** A pressurized sewer carrying wastewater.

**Freeboard:** The difference in elevation (expressed in feet) between the hydraulic grade line elevation and (1) the inlet sill elevation; or (2) the top of structure elevation; or (3) the top of channel bank elevation; or (4) the top of wall elevation.

**Frontage:** The edge of a lot bordering a street.

**Geotechnical Report:** A report, signed and sealed by an engineer, used to determine extent of development and grading, slope stability in the form of maximum slopes, sink hole conditions, need for

## Section 1 General Provisions and Requirements

interceptor ditches and any items that may affect the extent of development and/or location of structures on the site.

**Grade:** The rate of deviation of the ground surface from the horizontal surface, expressed in percentages.

**Highway:** Same as street.

**House Lateral:** Private sewer from building drain to the public sewer. This shall include the connection to the sewer.

**Hydraulic Grade Line:** A line coinciding with the level of flowing water at any given point along an open channel or sewer; or the level to which water would rise in a vertical tube connected to any point along a pipe or closed conduit flowing under pressure.

**HS-10:** The live truck wheel loads as designated by the AASHTO Specifications.

**HS-20:** The live truck wheel loads as designated by the AASHTO Specifications.

**IES:** Illuminating Engineering Society of America.

**Improved Channel:** Improved stormwater channels are open trapezoidal or vertical walled channels designed to certain standards and typically constructed from man-made structural materials, such as poured concrete, concrete block, placed stone, or gabion baskets.

**Improvements:** Street pavement, turning lanes, traffic signals, bridges and culverts, sidewalk and pedestrian way pavement, utilities, fire hydrants, storm sewers and roadside drainage ditches, erosion and siltation control, sanitary sewers, signs, monuments, landscaping, street lights, and other similar items.

**Inlet Time:** The overland flow time for runoff to reach the inlet.

**Land Surveyor:** An Illinois registered Professional Land Surveyor.

**LEED:** Leadership in Energy and Environmental Design.

**LLF:** Light Loss Factor: A percentage of the initial light output of a fixture that will be present at the maintained average life of the fixture.

**Low Sill:** The lowest elevation of any opening in a building.

**Main Sewer:** The principal sewer to which branch sewers and submains are tributary; also called trunk sewers.

## Section 1 General Provisions and Requirements

**Micro-Detention:** A single or series of small stormwater detention areas that absorb or detain some or all of the stormwater runoff in a development site. It works by temporarily storing stormwater near where it falls as precipitation. Micro-detention can include common landscaping features such as small garden areas, tree grates, perimeter hedges, and bioretention areas such as rain gardens. It may also include non-vegetated areas such as sub-surface storage areas with regulated outflow. Micro-detention is one of several best management practices that can be used to treat and/or infiltrate stormwater or collect it for reuse at a development site.

**MPH or mph:** Miles per hour.

**MUTCD:** Manual on Uniform Traffic Control Devices for Streets and Highways, U.S. Department of Transportation and the Federal Highway Administration (FHWA), Washington, D.C., as amended.

**NFPA:** National Fire Protection Association

**On-Street Parking Space:** A temporary storage area for a motor vehicle, which is located on a dedicated street right-of-way.

**Outfall:** Any point of discharge into a watercourse, or other body of surface or groundwater.

**Overland Flow Path:** A design feature of the major stormwater system which carries flows in excess of the minor stormwater system design capacity in an open channel or swale, or as sheet flow or weir flow over a feature designed to withstand the particular erosive forces involved.

**Parking Area:** An area of land used or intended for off-street parking facilities for motor vehicles.

**Parking Bay:** A paved vehicle storage area directly adjacent to the access street or privately controlled pavement.

**Parking Space:** A durably dust proof, properly graded for drainage, usable space, enclosed in a main building or in an accessory building, or unenclosed, reserved for the temporary storage of one vehicle, and connected to a street, alley, or other designated roadway by a surfaced aisle or driveway.

**Pave (Pavement):** The act or result of applying a hard, watertight material to any ground surface in such a manner as to present a uniform surface over a large area.

**Pedestrian Way:** An easement or right-of-way designated to facilitate pedestrian access to adjacent streets and properties.

**Pre-Development Runoff Rate:** The amount of flow from an existing site prior to new development or improvements as computed by the Rational Formula.



## Section 1 General Provisions and Requirements

**Private Sewer:** A sewer within the boundaries of the City but not owned or controlled by the City.

**PROWAG:** Public Rights-of-Way Accessibility Guidelines.

**Public Sewer:** A sewer which has been accepted for public maintenance by the City.

**Right-of-Way (R/W, R.O.W. or ROW):** A strip of land reserved or acquired by dedication, prescription, condemnation, gift, purchase, eminent domain or any other legal means, occupied or intended to be occupied by a street, sidewalk, railroad, utility, sewer, or other similar use.

**Road:** The entire width and length of the right-of-way or the easement of a road, street, avenue or boulevard or similar item.

**Roadway:** That portion of a road intended for use by the general traveling public, typically delineated by curbs, edge lines, edge of pavement.

**Sidewalk:** A paved area separate from the highway or roadway intended to be used by pedestrians.

**Sign, Guide:** A sign identifying entrances, exits, aisles, ramps, and similar traffic-related information.

**Shared-Use Path:** A paved area separate from the highway or roadway intended to be used by a variety of non-motorized users, including bicyclists, pedestrians, skaters, joggers, and others.

**Soils Report:** See Geotechnical Report.

**Springline:** The line or plane in which an arch rises from its impost. In circular conduits, the horizontal plane through the midpoint of the section.

**Steady Flow:** The quantity of water passing a cross section is constant, i.e., has patterns and magnitudes which do not vary with time.

**Steep Grade:** Roadway grades in excess of 6% or 8% as applicable to the street classification.

**Stormwater Drainage System:** All means, natural or man-made, used to convey stormwater to, through, or from a drainage area to the point of final outlet from a property. The stormwater drainage system includes, but is not limited to, any of the following: conduits and appurtenance features, canals, channels, ditches, streams, culverts, streets, storm sewers, detention basins, swales, and pumping stations.

**Stormwater:** Runoff from the surface of the land resulting from precipitation or snow or ice melt.

## Section 1 General Provisions and Requirements

**Stormwater Detention:** A stormwater runoff facility or feature designed to detain (hold) stormwater temporarily during and immediately after a runoff event.

**Stormwater Quality Management Facility:** A stormwater runoff facility or feature designed to improve quality and/or reduce volume of stormwater runoff (generally referred to as BMP). These facilities, to be approved, must properly use appropriate techniques and features as approved by the City over time and for intended water quality and/or volume reduction strategies and compliance goals.

**Street:** A public or private thoroughfare that affords the principal means of access to abutting property, including all facilities that normally occur within the right-of-way. The term shall also include such other designations as highway, thoroughfare, parkway, throughway, road, pike, avenue, boulevard, lane, place, court, but shall not include alley or a pedestrian way. The pavement requirements for private streets shall be the same as public streets except that special roadway sections may be used for drainage and perpendicular parking.

**Street, Access:** A private thoroughfare or driveway, which affords a means of access to parking areas and bays and to abutting buildings.

**Street, Arterial:** A major street so designated by IDOT and EWG, and utilized primarily for heavy volumes of traffic on a continuous route or for high vehicular speeds with intersections at grade.

**Street, Collector:** A secondary land service street that moves traffic from the arterial streets, and distributes traffic regionally, to the minor streets. Collector streets also may serve individual lots, parcels, and uses as a secondary or additional function.

**Street, Cul-de-Sac:** A street terminating in a circular turnaround.

**Street, Dead-End (No Outlet):** A street having only one point of ingress and egress.

**Street, Frontage or Service:** A secondary street, generally parallel and adjacent to arterial streets and highways, which provides access to abutting properties and protection from through traffic by way of controlled access points along arterial streets or highways.

**Street, Local Access:** Same as Street, Minor.

**Street, Loop:** A short, independent, minor street that usually terminates along the same collector street of its origin.

**Street, Minor:** A land service facility for access to abutting properties. Minor streets serve the local neighborhood and are in the form of a cul-de-sac or loop streets. Any combination of loop and cul-de-sac street may be utilized without the streets being designated as collector streets provided such an arrangement serves the same function.

## Section 1 General Provisions and Requirements

**Street, Multi-Family Access:** A private way or driveway which affords a means of vehicular access to parking areas and bays and to abutting buildings in a multiple dwelling unit subdivision.

**Street, Private:** A privately maintained thoroughfare which affords the principal means of public access to abutting property and which is constructed within private right-of-way or easements provided by adjacent property owners.

**Street, Public:** A street established and dedicated for public use.

**Time of Concentration:** Consists of inlet time plus the travel time in the sewer or channel from the most remote point in the watershed to the point under consideration.

**Travel Time:** The time it takes for the runoff to flow through the drainage system from one point of reference to the next point of reference.

**Unclassified Road:** All roads in the City of Collinsville which are not classified, typically a minor or local access street.

**Uniform Flow:** The flow in a channel, conduit or pipe, having a uniform cross section and velocity at every location within a given reach.

**Unimproved Channel:** Stormwater channels that have not been improved, including natural streams, stone revetments, and grad controls.

**Watercourse:** A natural or manmade surface drainage channel or body of water (including a lake or pond) in which a flow of water occurs, either continuously or intermittently.

**Water Quality Volume:** The storage volume needed to capture and treat runoff from the first inch of rain from a rainfall event to reduce stormwater nonpoint source pollution.

**Zero Increase Rate:** A routed release rate for a 24-hour storm, which represents no allowed increase in peak discharge.

## 1.020 Abbreviations

CFR	Code of Federal Regulations
FEMA	Federal Emergency Management Agency
IDNR	Illinois Department of Natural Resources
IDOT	Illinois Department of Transportation
IDPH	Illinois Department of Public Health
IEPA	Illinois Environmental Protection Agency
IUM	Illinois Urban Manual
MS4	Municipal Separate Storm Sewer System
MUTCD	Manual of Uniform Traffic Control Devices
NACTO	National Association of City Transportation Officials
NRCS	Natural Resources Conservation Service (formerly SCS)
OWR	Office of Water Resources (IDNR)
SCS	Soil Conservation Service (now NRCS)
SWCD	Soil and Water Conservation District
SWPPP	Storm Water Pollution Prevention Plan
USACE	U.S. Army Corps of Engineers
USDA	U.S. Department of Agriculture
USEPA	U.S. Environmental Protection Agency

## 1.030 General

This Manual gives the minimum acceptable criteria for new and modified public infrastructure facilities within the City of Collinsville. These requirements will provide better infrastructure throughout the City, reflecting best practices and support ongoing development and growth of the City of Collinsville.

Deviations or variances from these standards may be considered; however, it shall be the responsibility of the applicant to demonstrate to the satisfaction of the City Engineer the proposed variances meets or exceeds the minimum acceptable criteria. Any proposed waiver of a City Code provision may only be made according to the procedures set forth in the City Code. Policies and technical criteria not specifically addressed in this Section shall follow the provisions of the latest editions, or as noted in the Specifications, of the AASHTO's *"A Policy on Geometric Design of Highways and Streets"*, IDOT's *"Standard Specifications for Road and Bridge Construction"* and Illinois Society of Professional Engineers (ISPE), *"Standard Specifications for Water and Sewer Construction"*.

## 1.040 Utility Coordination

Locating and coordination for the relocation of existing utilities within the City's right-of-way is the responsibility of the contractor. JULIE and the City of Collinsville utility location service shall be utilized in addition to coordination with local utility owners. The contractor shall at all times protect existing utilities and will be responsible for costs due to damage caused to any utility lines.

## 1.050 Plan Standards

In order to provide consistency and maintain accuracies, the following criteria are required for the roadway plans.

Plans must be submitted in PDF, AutoCAD, and hardcopy form.

Exemptions to these standards may be granted by the City Engineer upon request, based on project scope and location.

### 1.050.01 Survey

Survey information in the form of point files must be included at the time of plan submission. All survey data gathering shall adhere to IDOT Standard Specifications.

Survey procedures require that all surveys be tied to the Illinois State Plane Coordinate System, West Zone. All surveyed coordinate values will be based on the North American Datum 1983 (NAD 83) coordinates. All elevations shall be based on National Geodetic Vertical Datum 1929 (NGVD 29). Appropriate notes indicating the coordinate system and vertical datum shall appear on the plans.

### 1.050.02 Civil Construction Plan Submittal

The plan submittal shall consist of neat, scaled drawings with specifications and any other pertinent supportive data as required for review approval. These drawings shall include all aspects of the street, grading and drainage, including documentation or supporting evidence that proves sufficient engineering calculations have been performed in accordance with the approved project or site plan. The civil construction drawings and drainage calculations shall bear the stamp of a Registered Illinois Professional Engineer. Other submittals for approval which are necessary and to be done by the Developer may include, but are not limited to the Illinois Department of Transportation, the Illinois Environmental Protection Agency, and the Illinois Department of Natural Resources.

As a general guideline, the *supporting calculations shall include any engineering information that is pertinent to the project*. These may include, but are not limited to the following:

- Drainage calculations including culvert and bridge analysis, drainage areas, runoff values, energy dissipators
- Intersection sight distance calculations
- Quantity calculations (City projects)
- Structural calculations

The designer is encouraged to add notes on the plans explaining special situations or items which are not readily apparent and that would influence the proposed design. The

## Section 1 General Provisions and Requirements

following sheets and information will be reviewed for quality assurance at this submission:

1. Cover Sheet
  - Project numbers
  - Project location map including north arrow and scale
  - Description of project work type
  - Design data including current zoning, proposed zoning, land use type, site area, total area disturbed, existing impervious area, proposed impervious area, parking space calculations (including required and proposed), design speed, design criteria, functional classification of roadways, traffic data, etc.
2. Subdivision Plat
3. General Notes
4. Approved Site Plan (commercial projects)
5. Dimensional Control Plan (commercial projects)
  - Dimensions for all buildings, pavement and hardscape areas (i.e. parking areas, driveways, fire lanes, turn lanes, sidewalks, radii, etc.) measured to the nearest 0.0'
  - Control points to structures (i.e. inlets, manholes, etc.) based on dimension from property corner or known feature (not from an arbitrary point parallel to property line)
  - Verification of public right-of-way widths. Dimension each property corner adjacent to public right-of-way to a perpendicular point on opposite side of right-of-way line (do not label "variable width" only)
  - Dimension along right-of-way to nearest cross-street and/or driveway measured from edge of drive to edge of drive
6. Tree Survey
  - Property lines, right-of-way and easements shown and dimensioned
  - All buildings, structures, and utilities (existing and proposed) shown
  - FEMA floodway and 100-yr floodplain
  - Show existing and proposed grading contours
  - List in table format, the species and size of all trees at least 6" in caliper measured at 4.5' trunk height from ground
  - Show surveyed location of trees
7. Tree Preservation Plan

## Section 1 General Provisions and Requirements

- Property lines, right-of-way and easements shown and dimensioned
  - All buildings, structure, and utilities (existing and proposed) shown
  - FEMA floodway and 100-yr floodplain
  - Show existing and proposed grading contours
  - List in table format, the species and size of all trees at least 6" in caliper measured at 4.5' trunk height from ground
  - Show surveyed location of trees and note existing trees to remain, trees to be removed and/or replacement tree types
  - Show tree preservation fencing, and include standard fencing detail placed at drip line
8. Erosion and Sediment Control Plan
- Existing and proposed contours clearly shown/labeled, drainage clarified by flow arrows.
  - Existing and proposed storm lines, inlets and manholes shown.
  - List the total disturbed acreage including offsite and delineate limits of construction.
  - Location of the grading limits line.
  - Location of FEMA floodway and 100-yr floodplain delineated
  - Location and description of the erosion and sediment control measures to be employed during construction
  - For an structures proposed to be located within the grading limits, the map shall include the limits of disturbance including tree removal, erosion and sediment control measures during construction, cross section view of any proposed cut or fill, erosion and sediment control measures during construction, details of method(s) proposed for providing slope stability, permanent stormwater control measures, and permanent erosion and sediment control measures all being certified by a registered professional engineer or a "Certified Professional Erosion Control Specialist."
  - The predominant soil types on the site, their location, and their limitations for the proposed use as defined by the USDA Natural Resources Conservation Service.
  - The proposed use of the site, including present and planned development, areas of clearing, stripping, grading, excavation and filling; proposed contours, finished grades, and street profiles; existing and proposed storm lines, inlets and manholes; depressional storage areas; detention/retention facilities; kinds and locations of utilities, areas and acreages proposed to be paved, sodded or seeded, vegetatively stabilized, or left undisturbed; and the location and specimen of trees over eight (8) inches in diameter.
  - Location and description, including standard details, of all sediment control measures, runoff control measures, including diversions, waterways and

## Section 1 General Provisions and Requirements

outlets, and design specifics of sediment basins and traps including outlet details.

- Location and description of all soil stabilization and erosion control measures, including seeding mixtures and rates, types of sod, method of seedbed preparation, expected seeding dates, type and rate of lime and fertilizer application, kind and quantity of mulching for both temporary and permanent vegetative control measures, and types of non-vegetative stabilization measures.
- Location and description of methods to prevent tracking of sediment off-site including construction entrance details, as appropriate.
- Description of dust and traffic control measures.
- Locations of stockpiles and description of stabilization methods.
- Locations of concrete washouts and batch plant area shown and labeled.
- Locations of off-site fill or borrow volumes, locations and methods of stabilization.
- Provisions for maintenance of control measures, including type and frequency of maintenance, easements, and estimates of the cost of maintenance.
- The proposed phasing/staging of development of the site, including stripping and clearing, rough grading and construction, and final grading and landscaping. Phasing should identify the expected date on which clearing will begin, the estimated duration of exposure of cleared area, and the sequence of installation of temporary sediment control measures (including perimeter controls), installation of storm water drainage, paving of streets and parking areas, final grading and the establishment of permanent vegetative cover, and the removal of temporary measures. It shall be the responsibility of the applicant to notify the City Engineer of any significant changes which occur in the site development schedule after the initial erosion and sediment control plan has been approved.

### 9. Drainage Plan

- A topographic survey of the property at one (1) foot contours unless otherwise approved by the City Engineer.
- Property boundary, dimensions, and approximate acreage
- Area of existing and proposed impervious surface in square feet
- List the total site open space area (acres) – Residential Projects
- All existing or proposed easements
- All existing, abandoned, or proposed water or monitoring well head locations
- All sanitary and private sewage systems
- The banks and centerline of streams and channels



## Section 1 General Provisions and Requirements

- Shoreline of lakes, ponds, and detention basins with normal water level elevations
- Known farm drains and tiles
- Soils classifications
- Location, size and slope of storm water conduits and drainage swales
- Depressional storage areas
- Detention/retention facilities
- Roads, streets and associated storm water inlets including finished grades
- Base flood elevation, flood fringe, and regulatory floodway
- Wetlands delineated where applicable, and delineate areas to be protected from disturbance
- Location of known sinkholes
- Known proposed environmental mitigation features
- Basis of design for the final drainage network components
- A statement giving any applicable engineering assumptions and calculations
- Cross-section data for open channel flow paths and designated overland flow paths
- Direction of storm flows
- Off-site drainage areas contributing to the site
- Flow rates and velocities at critical points in the drainage system (may be included in the hydraulic report)
- A statement by the design engineer of the drainage system's provision for handling events greater than the 100-year, 24 hour runoff (may be included in the hydraulic report)
- A statement of certification of all drainage plans, calculations, and supporting data by a Licensed Professional Engineer.
- Description of long-term operation and maintenance of BMPs

### 10. Grading Plan

- Both onsite and offsite existing/proposed contours shown clearly labeled
- Date and name of firm who prepared geotechnical report with corresponding note stating: "Work shall be done in accordance with Geotechnical Report by \_\_\_\_\_, dated \_\_\_\_\_."
- Drainage clarified by flow arrows, high points, sags, ridges, and valley gutters
- Show driveway locations for all lots adjacent to storm inlets
- Positive overflow provided at all low points; easements dedicated as needed
- Finished pad and/or floor elevations shown
- Minimum finished floor elevations shown adjacent to floodplains, ponds, creeks/channels, storm sewers, etc.
- Clearly show all walls and label top/bottom elevations of walls at key

## Section 1 General Provisions and Requirements

locations

- Base flood elevation, flood fringe, and regulatory floodway (show both pre and post project floodway and floodplain.
- Cross-sections and flow data for all swales and open channels provided
- Spot shots shown to ensure proper drainage and adequate ADA/IAC routing where applicable

### 11. Storm Water Pollution Prevention Plan (SWPPP)

- Purpose
- Construction site description
- Activities/materials to be addressed
- Construction site operating procedures
- Activities/materials monitoring and maintenance
- Emergency and spill procedures

### 12. Drainage Area Map

- Existing contours clearly shown for entire drainage basin, both onsite and offsite. Aerial topography or similar is acceptable for offsite areas with major contour labels shown
- Drainage area and sub areas delineated and labeled
- Flow arrows for surface drainage shown
- Existing and proposed storm lines and open channels shown
- Inlet designation labels shown
- Detention pond shown and labeled
- Drainage easements shown and labeled
- Zoning indicated for all offsite areas and/or land use assumptions specified
- List the total site impervious area (sq. ft. of all paving, roof areas, etc.) – Commercial Projects
- Base flood elevation, flood fringe, and regulatory floodway

### 13. Storm Drain Plans

#### Plan View

- Show and label all proposed and existing utilities
- Dimension and location/spacing of utilities
- Label inlet type, invert elevations, and top of curb elevation at a minimum
- Label type and size of existing/proposed structures (i.e. headwalls, manholes/junction boxes)
- Label type, size and dimensions of all permanent outfall erosion protection
- Show centerline stationing for pipe with PC & PT stations and curve data
- Label centerline sections for lateral connections, manhole & junction box locations, pipe size changes, headwalls, and future stub out connections

## Section 1 General Provisions and Requirements

- 100-yr gutter flows and bypass shown at each inlet along public streets and fire lanes
- Base flood elevation, flood fringe, and regulatory floodway
- Provide applicable construction details for all drainage structures

### Profile View

- Existing and proposed ground line and centerline of pipe shown and labeled correctly
- Show all hydraulic data including design flow, full flow capacity, hydraulic grade line, and velocity
- Label station and flowline elevation information for all structures, crossings, laterals, etc.
- Indicate length, type/class, slope and size of all storm pipes
- All utility crossings and parallel sewer lines shown in profile
- Open channels shall also include a typical cross section with all hydraulic data

## 14. Water Plans

### Plan View

- Show and label all existing and proposed utilities
- Label size, type and pressure class for all proposed water mains
- Show location for all water services and meters
- Show and label all easements
- Dimension and location of all mains, services, meters, and spacing from other utilities
- Curve data a stationing provided as necessary
- Show and label all fire hydrants, valves, fittings, and backflow prevention

### Profile View

- Profile all water mains 12" and larger, or where a potential conflict may arise
- Existing and proposed ground line at centerline of pipe shown and labeled correctly
- Indicate length, type/class and size of all lines
- All utility crossings and parallel sewer/storm lines shown in profile
- Indicate length, type and size of encasement as needed

## 15. Sanitary Sewer Plans

### Plan View

- Show and label all existing and proposed utilities
- Dimension and location of all mains from other utilities

## Section 1 General Provisions and Requirements

- Label line name, size and type/class
- Stub-outs labeled with size, slope, length and flowline elevations
- Show and label all easements
- Show centerline stationing for sanitary sewer
- Show and label all manholes with invert and rim elevations, as well as cleanouts
- Indicate type and size of encasement as needed
- Show flow direction arrows for sewer main

### Profile View

- Profile shown for all mains 8" and larger, or where a potential conflict may arise
- Existing and proposed ground line at centerline of pipe shown and labeled
- Label station and invert elevation information for all manholes, cleanouts, crossings and laterals
- Indicate the type and diameter for all manholes
- Indicate length, type/class, slope and size of all sanitary sewer pipe between manholes
- All utility crossings and parallel storm lines shown in profile
- Indicate type and size of encasement as needed

## 16. Paving Plan

### Plan View

- Horizontal alignment
- Typical Pavement Section details shown (fire lane, parking areas, streets, subgrade, etc.)
- For streets, centerline stationing at every 100 feet, PC's, PT's, and curve data labeled
- Intersection, driveway and island curb radii labeled
- All sidewalks and curb ramps shown, labeled and dimensioned
- Existing, proposed, future streets and drives shown and labeled
- Right-of-way corner clips and sight distance easements provided
- Storm inlets identified with paving stations and top of curb elevations at center of inlet
- Drainage clarified by flow arrows at crests, sags, ridges, intersections, and valley gutters
- Show driveway locations for all lots adjacent to storm inlets and intersections

### Profile View

- Typical cross sections to include lane and shoulder widths, cross slopes,

## Section 1 General Provisions and Requirements

pavement details, curbs, sidewalk locations and widths, bicycle facilities, side slopes, etc.

- Vertical alignment with vertical curve stationing and elevations including PVC, PVI, PVT, crest/sag location, curve length, algebraic grade difference, and “K” values shown at a minimum
- Street grades shown to the nearest 0.0’. Max and min grades per [Section 2.030.09, Vertical Alignment](#).
- Show “compacted fill” callout/note for all areas of fill

### Typical Cross Sections

- Lane and shoulder widths tied to centerline
- Construction centerline
- Profile Grade Line
- Cross slopes
- Pavement Design
- Station ranges/limits
- Curbs
- Sidewalk locations and widths
- Bicycle facilities
- Side slopes
- Shoulder configurations if warranted
- Retaining walls, culverts, and bridges if warranted
- Ditches, Seed/Sod areas

### Detail Sheets

- Turning movements and turn lanes
- Pavement markings
- Signals
- Signs, including sign structures
- Superelevation transition structures

### 17. Sidewalk Layout Plan

- Provide a single scalable sheet showing all sidewalks/shared-use paths to be installed with the development
- Show actual layout locations and sizes of all proposed sidewalks and curb ramps
- Specify the type of curb ramp used at all locations
- Show curb ramp details

### 18. Construction Details

- Lighting

## Section 1 General Provisions and Requirements

- Retaining walls
- Special drainage structures
- Plans for traffic maintenance details and traffic design elements (intersections, signals, signing and lighting)

19. Landscape Plan (residential and commercial projects)

20. Screening and Buffering Plans (residential and commercial projects)

21. Attachments

- Hydraulic Calculations
- Detention Calculations
- Transportation Impact Analysis (TIA)
- Intersection Design Study (IDS)
- Geotechnical Report including pavement design

### **1.060 Notification of Construction**

In addition to any other notices required by law (e.g., JULIE, notices to non-participating utilities), before commencing construction operations, a 72 hour notice must be given during regular business hours to:

- City Engineers Office and the Public Works Department for streets, sidewalks, and storm sewers
- Water Department for water mains
- Sewer Department for sewer mains

This advance notice is required for all public infrastructure construction projects to ensure proper inspection staff scheduling. Demolition permits, if required for the project, shall be obtained from the Community Development Department.

### **1.070 Quality Control Testing**

Construction materials, including aggregate base stone, asphalt, concrete, and roadway sub-grades shall be fully tested in accordance with the designations and requirements of IDOT's "*Standard Specifications for Road and Bridge Construction*".

Testing shall be done by an independent testing laboratory whose qualifications are approved by the City. Testing results shall be submitted to and approved by the City Engineer. The City reserves the right to require industry standard certifications of testing and inspections by the testing laboratory, mills, shops and factories. Such certification required shall be submitted in duplicate.

The Developer shall provide the necessary labor and supervision required to support field testing by the independent testing firm and inspections by City Officials at no cost to the City. Test reports of field testing if applicable shall be submitted directly to the City Engineer. Defects disclosed by tests shall be rectified at no cost to the City. The Developer is required to have the design engineer or a certified

## Section 1 General Provisions and Requirements

quality control inspector present during all phases of construction. A daily log of work performed shall be kept by this individual and submitted to the City upon request.

### 1.080 Inspection

All projects shall be subject to inspection during and upon completion of construction by an authorized representative(s) of the City. Presence or absence of an inspector during construction does not relieve the Developer and/or Contractor from adherence to approved plans and material contained in these specifications or from liability. Materials and/or workmanship found not meeting requirements of approved plans and specifications shall be immediately brought into conformity with said plans and specifications.

An authorized representative of the City shall make a final inspection of the project after completion to determine acceptability of the work and for release of performance bonds if required. Before this final inspection can be made, the Engineer responsible for the project shall certify in writing to the City Engineer that the work has been completed in accordance with approved plans and specifications.

The cost for inspection during construction is calculated and paid as part of the **Land Development Permit**. Additional inspection fees will be required only when an inspection requiring City approval fails and requires subsequent re-inspections. The **Permit Fees** (current prices can be found in the Title 4 of the Collinsville Municipal Code) shall be paid to the City before issuance of Permits.

Water facilities including, but not limited to, water mains, valves and hydrants shall be inspected, tested and given approval at each stage

### 1.090 As-Built and Record Drawings

#### 1.090.01 As-Built Plans

The following requirements apply to As-Built Plan Submittal

**1. As-Built Review Process**

A set of redline plans must be submitted with “as-built” redline markings to the Department of Public Works for review. These markings must represent actual as constructed conditions. Once the redline as-builts are approved and accepted by the Department of Public Works the final as-builts can be prepared and submitted.

**2. As-Built Plans**

One set of as-built plans will be provided as a hard copy, printed and bound in 24”x36” size. As-built plans shall be signed and sealed by an Illinois registered engineer or an Illinois registered professional land surveyor as applicable, prior to producing the hard copies. In addition, the original signatures of the approval block shall be intact.

**3. Test Results, Certifications, Registrations and Reports**

The following is a summary of documents that will be required as part of the as-built

## Section 1 General Provisions and Requirements

submittal.

- A. Compaction, Density Test Results for Bedding, Backfill, Sub-grade, Base Materials and Pavement.
- B. Pressure and Leakage Testing.
- C. Disinfection Testing.
- D. Drilling Logs, Registration and Certification.
- E. Closed Circuit Television (CCTV) DVD for the sanitary and storm sewer systems.
- F. Coating System Test results
- G. Percolation Test Results for all basins.
- H. Certified Pad or Finished Floor Elevations.
- I. Certification of Provision of Required Retention Volume.
- J. Signal Phase Timing Charts.
- K. Well Abandonment Registration of Certification.
- L. Acknowledgement of Completion to Satisfaction of other Jurisdiction or Agency requirements.
- M. Final Drainage Report.
- N. Operation, Service and Maintenance Manuals.
- O. Warranties.
- P. Pavement Evaluation Report.
- Q. Survey Monument Replacement.



Section 1 General Provisions and Requirements

**4. As-Built Certification**

The following As-Built Certification statement must be added to the plans and executed:

AS-BUILT CERTIFICATION

I HEREBY CERTIFY THAT THE "AS-BUILT" MEASUREMENTS AS SHOWN HEREON WERE MADE UNDER MY SUPERVISION OR AS NOTED AND ARE TRUE AND CORRECT TO THE BEST OF MY KNOWLEDGE AND BELIEF.

\_\_\_\_\_  
Registered Land Surveyor                      Registration No.                      Date

Contractor: \_\_\_\_\_

Permit No.: \_\_\_\_\_

Approval Date: \_\_\_\_\_

By City Inspector: \_\_\_\_\_

NOTICE:

THE CITY OF COLLINSVILLE ASSUMES NO RESPONSIBILITY FOR THE ACCURACY OF THE "AS-BUILT" INFORMATION PROVIDED AS PUBLIC RECORD.

**1.090.02 Record Drawings**

Record Drawings are only required on facility or utility facility projects. Record Drawings will be used by the City of Collinsville or their designees for facility maintenance and/or future project modifications. Typically, projects requiring Record Drawings will be City of Collinsville Capital Improvement projects or City of Collinsville Operational projects. However, if a developer is required to construct a facility or utility facility with a development project, then record drawings are required by the City.

The term "Record Drawing" shall mean that drawing prepared for submission to the City of Collinsville by Applicant. A "Record Drawing" is prepared in CAD and contains the Registrant's corrections to the drawings based on as-built constructed conditions (RFI clarifications, field sketches, and scope additions/deletions) in addition to the construction markings provided by the Contractor. Record Drawings represent the combined knowledge of the Designer and Contractor as the accurate representation of the constructed facility for the benefit of the City of Collinsville and shall be prepared by the Design Firm of Record.

## Section 1 General Provisions and Requirements

### 1. **Record Drawing Certification**

The following Record Drawing Certification statement must be added to the plans and executed:

RECORD DRAWING CERTIFICATION

I HEREBY CERTIFY THAT THESE RECORD DRAWINGS WERE MADE UNDER MY SUPERVISION OR AS NOTED AND ARE CORRECT TO THE BEST OF MY KNOWLEDGE AND BELIEF.

\_\_\_\_\_

Registered Land Surveyor

\_\_\_\_\_

Registration No.

\_\_\_\_\_

Date

### **1.100 Acceptance of Facilities**

After construction has been completed, a final inspection will take place by the City. City acceptance occurs when a Final Letter of Acceptance is issued by the City and the City of Collinsville releases performance bonds.

#### **1.100.10 Final Letter of Acceptance**

The Final Letter of Acceptance will be granted when the entire project is completed. To obtain the Final Letter of Acceptance, the following items must be approved:

1. All work shown on the approved plans completed and installed.
2. Pavement Design approval.
3. Compaction reports approved.
4. All concrete work (curb, sidewalk) is accepted, or if cracked, replaced if a hazard (tripping, etc.).
5. Completed BMP Maintenance Agreement executed and recorded copy received by the City.
6. "As-built" drawings, certified by an Illinois registered land surveyor or Illinois registered professional engineer for:
  - A. Grading and Drainage including certificates of pad elevations or finished floor elevations, retention/detention basin elevations and flood zone determinations.
  - B. Sanitary sewer system, including dimension between manholes, actual location of services and length of services installed, rim and flowline elevations and type of pipe, etc.
  - C. Water system, including valve locations, depth of water line, type of pipe, actual

## Section 1 General Provisions and Requirements

location of services, dimension to hydrant locations, dimensions to tees and crosses.

- D. Paving, curb, gutter and sidewalk, including locations and widths of driveways, elevations, and streetlight locations.
- E. Storm Drain, including type of pipe, dimension of pipe, and location of structures with rim and flowline elevations.
- F. Bank stabilization, if any included in as-builts.
- G. Traffic signal/stripping and signage.
- H. Provide CAD drawings, compatible with City software of the water, sewer, and storm drain system base maps with as-built locations of the mains.

7. All fees must be paid.

8. All streetlight installation costs have been paid.

### **1.100.20**      **Warranty**

The Final Letter of Acceptance will constitute the beginning of the 2-year warranty.

### **1.110 Modifications**

Occasions may arise where the minimum standards are either inappropriate or cannot be justified economically. Modifications from the standards in this Manual will be considered by the City Engineer on a case-by-case basis using the following criteria:

- Whether the modification requested complies with acceptable engineering standards;
- Whether the modification requested does not present a danger to the general health, safety or welfare to the traveling public or pedestrians; and
- Whether the modification is necessary and meets or exceeds the standard using acceptable alternative design or methods.

If the developer, contractor, or utility responsible to the City for public improvements desires to design and construct such improvements in modification of these standards, such modification(s) shall be identified in a written attachment to the initial submittal of plans. A request for modification shall be denied if the following information is not provided:

- Identification of the standard provision to be modified.
- Identification of the alternative design or construction standards proposed.
- A thorough justification of the modification request including impact on short- and long-term capital and maintenance requirements and cost.
- Request shall be prepared and sealed by an Illinois registered professional engineer.

## Section 1 General Provisions and Requirements

### **1.120 Appeal of City Engineer Order or Decision**

Any person aggrieved by any order or determination of the City Engineer may appeal said order or decision in the manner as provided for in Chapter 15.48 of the City's Code of Ordinances.

### **1.130 Revision to these Specifications**

These specifications will be adopted by ordinance of the City Council of Mayor and Council Members and shall be revised by ordinance; however, forms and administrative procedures or regulations to effectuate the intent of these specifications are subject to change as deemed necessary by the City Engineer with thirty (30) days' notice from posting on the City's website or advertising in a publication of general circulation within Madison and St. Clair County and placed on file at the City Clerk's Office and at the City Engineer's Office for public inspection and written comment.

## Section 2 Design Requirement for Transportation Facilities

### 2.010 Standards for Street Design

The purpose of this Section is to present the City criteria and guidelines for the design of conventional streets and other related elements in the street right-of-way. It is to be used by the City, developers and their engineers in the design of public and private streets for which approval by the City Engineer is required.

#### 2.010.01 General

All design drawings and support data submitted to the City Engineer for approval must be sealed by an Illinois registered professional engineer.

The design criteria, as presented, are intended to aid in preparation of plans and specifications and include minimum standards where applicable. These design criteria are considered minimum and a complete design will usually require more than is presented in this Manual. Design of streets shall follow IDOT's *"Local Roads and Streets Manual"* and IDOT's *"Standard Specifications for Road and Bridge Construction"* unless otherwise noted in these specifications. For items not addressed by IDOT's *"Local Roads and Streets Manual"* and IDOT's *"Standard Specifications for Road and Bridge Construction"*, AASHTO's *"Green Book"* and other relevant AASHTO design documents shall be consulted for guidance. Where conflicts exist or interpretations are required, the City Engineer shall make the final determination in consultation with the designer.

#### 2.010.02 Location and Layout of New Streets

The location and layout of new streets shall support the Future Land Use Map and meet the needs of the specific development and satisfy all other specific requirements of this Section. The City Engineer retains the authority for approval of the overall street layout.

All streets shall have a logical relationship to the existing topography and to the location of existing, platted or planned streets within adjacent properties. Proposed streets should support a rectangular grid or modified grid street network to the maximum extent practicable. Curvilinear street networks shall only be used when topographic or environmental constraints make use of the grid pattern undesirable, or when established development patterns on adjacent lands make the grid pattern infeasible.

The street layout for all subdivisions shall be designed to ensure connectivity, enhance general circulation and to provide a secondary point for emergency access. They shall also provide safe, efficient, and convenient vehicular, bicycle, and pedestrian access within and between developments. Certain streets may need to be extended to property boundaries to provide for the future logical extension of the street through adjacent properties. If an arterial or collector street is located within or adjacent to a development, the development shall continue the street to a logical termination point as determined by the City Engineer.

## Section 2 Design Requirements for Transportation Facilities

A major component in street layout is neighborhood traffic safety. This is an essential transportation issue in the City. Streets shall be designed to limit excessive traffic speeds and volumes in neighborhoods and provide for safe travel for all modes of transportation including pedestrian, bicycle, and vehicles. In addition, new streets in neighborhoods shall be laid out to minimize opportunities for cut-through traffic.

### **2.010.03 Circulation Plan and Transportation Impact Analysis Required**

All new development and redevelopment in the City shall prepare a Circulation Plan. The Circulation Plan shall address street connectivity, emergency and service vehicle access, parking movements, accommodation of loading operations, and similar issues. The City Engineer may waive the requirement for a Circulation Plan on a case-by-case basis in the event that, in his/her opinion, a new development has no anticipated impact upon circulation, or proposes no change in existing circulation patterns. See Title 17 of the Collinsville Municipal Code for more information on requirements for Circulation Plans.

As part of the required Circulation Plan, the City Engineer or his/her designee may require that a transportation impact analysis (TIA) be prepared for developments or projects meeting the criteria specified in this subsection. The TIA shall consider traffic capacity and service, traffic controls, intelligent transportation systems (ITS), multi-modal accommodations and safety issues in accordance with the following standards:

#### 1. When Required

A TIA shall be required to assess the transportation impacts of a proposed development or project when:

- A. The expected number of primary trips generated by a proposed land use exceeds an estimated 1,000 vehicle trips per day or 100 peak hour vehicle trips per day; or
- B. A proposed land use generates less than 1,000 vehicle trips per day, or 100 peak hour trips per day when:
  - (1) The use is on a site located at or within 600 feet of an existing or planned signalized intersections; or
  - (2) The proposed land use may constitute a danger to the safe and efficient flow of traffic, as determined by the City Engineer or his/her designee.

#### 2. Preparation of TIA

A TIA shall be prepared by an Illinois registered professional engineer using the standard format specified by the Institute of Transportation Engineers (ITE's), "*Transportation Impact Analysis for Site Development*", in accordance with the

## Section 2 Design Requirements for Transportation Facilities

following:

### A. Initial Meeting

Prior to the preparation of a TIA, the preparer shall review the following with the City Engineer or his/her designee:

- (1) Study methodology and assumptions;
- (2) The study area designation;
- (3) The development phasing, sequence and timing;
- (4) The study horizon year;
- (5) The time periods to be analyzed;
- (6) Other approved developments in progress; and
- (7) Planned or on-going relevant roadway projects.

### B. Preliminary Data Requirements and Draft Findings of the TIA

The applicant shall provide the following information at the time of the initial submittal of the plan review application:

- (1) Traffic analysis base information, site location map, site layout, if applicable;
- (2) Data on the existing/proposed land use;
- (3) Description of the project;
- (4) Draft findings of the TIA; and
- (5) Additional information as may be required by the City Engineer from the initial meeting up to the time of the initial submittal.

### C. Study Area Boundaries

The extent of the study area for the TIA depends upon the location and size of the proposed development and the prevailing conditions of the surrounding area. The study area is defined in the following [Table 2.1](#). The distances described below are to be measured from the property boundaries and include those intersections within the identified area.

Section 2 Design Requirements for Transportation Facilities

STUDY AREA BOUNDARIES	
Trip Generation	Study Area
100 - 150 peak hour trips	One-half (1/2) mile plus any intersection on which at least seven percent (7%) of any traffic movement approach volume is generated by the proposed project.
More than 150 peak hour trips	One (1) mile plus any intersection on which at least seven percent (7%) of any traffic movement approach volume is generated by the proposed project.

**Table 2.1**

D. Minimum Requirements/Data in the TIA

The TIA shall evaluate the projected impact of the proposed development on the public and private facilities in the study area at the time of projected build-out. Build-out shall be assumed to be five (5) years from the date the application was submitted. The applicant may request that the City Engineer or his/her designee approve an alternative build-out timeline for the City to take into consideration during the study

The TIA shall take into account not only the status of existing facilities and the impact of the proposed development, but also the projected impact of the following items on the capacity of those facilities:

- (1) Future capital improvements that will increase the capacity of the facilities in question shall be considered;
- (2) All single-family residential building lots that have received final plat approval but that do not contain a completed dwelling;
- (3) All single-family residential building lots for which development plan approval has been granted and all non-residential and multifamily residential developments for which a development plan or preliminary plat has been approved;
- (4) Proposed developments or projects that have received a notice to proceed to begin the preparation of a TIA;
- (5) Current City and State traffic counts for surrounding streets;
- (6) Any additional traffic counts performed as a part of preparing the study;



## Section 2 Design Requirements for Transportation Facilities

- (7) Trip generation and directional distribution;
- (8) Traffic assignment to streets and access locations;
- (9) Traffic forecasting for twenty-four-hour and a.m. and p.m. peak hour traffic (on-site and off-site), including mid-day peak hour for nonresidential development;
- (10) Safety analysis, capacity analysis and level of service of adjoining streets, and nearby intersections (including at least one signalized intersection beyond the project boundary) before and after the proposed full development;
- (11) Recommendations for Intelligent Transportation System (ITS) elements, if applicable.

### E. Trip Generation Standards

Trip generation data for each project shall be based upon the most current edition of the ITE's, "*Trip Generation Manual*" or, at the discretion of the City Engineer, other sources of trip generation data (e.g., local data) may be used if it is deemed to be more representative of the proposed development use.

The following additional standards shall also apply:

#### (1) **Credit for Mixed Use, Pass-By Trips**

The determination of the number of trips generated shall also account for pass-by trips, internal trip capture for integrated mixed use projects (e.g., roadway and/or pedestrian connectivity) and any proposed transportation demand management system, provided that adequate guarantees can be provided to the City to ensure that such demand management system shall function as claimed for the life of the project. In addition, if the proposed development is designed and integrated with an adjacent mixed use project (e.g., roadways), then a credit for trips may be permitted.

#### (2) **Estimated Trips for Rezoning**

In evaluating the impact of a proposed rezoning where the specific uses or exact number of dwelling units have not been specified, estimates shall be based upon the highest level of density or intensity of use that would be authorized by the requested approvals. However, if the highest level of intensity of use is a use that generates trips that meet or exceed the threshold but do not occur during the adjacent roadway system's peak

## Section 2 Design Requirements for Transportation Facilities

hour, such as athletic fields, outdoor amphitheaters, or other similar uses, then the analysis shall be based upon the normal trip generation for the proposed use and not that associated with special event(s).

### F. Minimum Level of Service Standards

The following minimum levels of service shall be maintained before, during, and after new development or redevelopment in accordance with the following:

#### (1) Roadway and Intersection Operation

All intersections involving at least one arterial roadway shall be a minimum Level of Service D based upon the standard ITE average peak hour. All other intersections shall be required to maintain a minimum Level of Service C based upon the standard ITE average peak hour.

#### (2) Intersection Turning Movements

Lanes used for turning movements within intersections shall maintain a minimum Level of Service D. Where forecasted conditions without the site traffic indicate levels of service below the acceptable minimum threshold, the developer shall perform all improvements necessary to restore the pre-development level of operation.

### 3. Draft Findings of TIA

If a TIA is required, the City shall not accept a plan review application unless the applicant submits the Draft Findings of the TIA or documentation that the City Engineer or his/her designee has granted an extension to the deadline for submitting the Draft Findings.

### 4. Review and Approval of a TIA

The City Engineer or his/her designee shall review and approve the TIA submitted by the applicant. If the TIA is for a high profile project the City of Collinsville shall utilize a retained consultant to provide a third-party review of the TIA and the City Engineer or his/her designee shall review and approve the findings of the review prepared by the retained consultant and approve the TIA submitted by the applicant.

### 5. Expiration of TIA

The TIA shall expire after three (3) years from the date of approval of the TIA by the City Engineer or his/her designee. After the expiration of the TIA, the applicant shall submit an updated TIA prior to submitting an application to revise an approved development or project.

### 6. Appeal of TIA Methodology

## Section 2 Design Requirements for Transportation Facilities

Applicants shall have the option to appeal the determination of the TIA by submitting a formal appeal in writing to the City Engineer. If the City Engineer does not approve the appeal, then the applicant shall have the option to appeal the determination of the TIA and the City Engineer in the manner as provided for in Chapter 15.48 of the City's Code of Ordinances.

### **2.010.04 Connectivity**

Circulation Plans shall achieve internal street connectivity by providing multiple connections to the existing City street network wherever possible. Whenever cul-de-sac streets are created at least one ten-foot-wide trail easement shall be provided, to the maximum extent practicable between each cul-de-sac head or street turnaround and the sidewalk or trail system of the closest adjacent street, pedestrian sidewalk or pathway, or bicycle or shared-use path. In addition to the internal street connectivity, Circulation Plans shall maintain external street connectivity in accordance with the standards set forth in Title 17 of the Collinsville Municipal Code. To encourage shared access points on public streets, Circulation Plans prepared for all new attached residential, nonresidential, and mixed-use development shall also facilitate cross access between adjacent land uses.

### **2.010.05 Private Streets**

Private streets serving more than one lot shall be built to the same standards as required for public streets and shall be located in public utility, drainage and access easement.

### **2.010.06 Applicability**

In the event of conflict or overlap with the street design requirements in this Manual and the requirements of Title 16 and 17 of the Collinsville Municipal Code, the standards and specifications in this Manual shall control.

## **2.020 Street Classification and Right-of-Way**

### **2.020.01 Functional Classification**

East-West Gateway Council of Governments (EWG) is responsible, in cooperation with the Illinois department of Transportation (IDOT), for updating the Roadway Functional Classification System for the City of Collinsville. The City has further classified some of the Local Streets as Alleys and Private Streets. Roadways are classified according to their urban or rural setting and the type of service they provide based on considerations such as: connectivity, mobility, accessibility, vehicle miles traveled, average annual daily traffic, and abutting land use.

#### **1. Other Principal Arterial**

These roadways serve major centers and provide a high degree of mobility. They include access to abutting land and at-grade intersections with other roadways.

There are two other principal arterial roads in the City of Collinsville:

## Section 2 Design Requirements for Transportation Facilities

- Illinois Route 157
- Illinois Route 159

### 2. Minor Arterial

These roadways provide service for trips of moderate length, serve geographic areas that are smaller than their higher arterial counterparts, and offer connectivity to the higher arterial system. They interconnect and augment the higher arterial system and provide intra-community continuity. The following are minor arterial roads in the City of Collinsville:

- Belt Line Road
- Clay Street (N. Combs Ave. to IL-159)
- Collinsville Road
- Horseshoe Lake Road
- Keebler Avenue (Belt Line Rd. northward)
- Main Street (IL-157 to IL-159)
- Saint Louis Road

### 3. Collector

These roadways serve a critical role in the roadway network by gathering traffic from local roads and funneling them to the Arterial network. Major collectors serve a medium volume of traffic at lower speeds than Arterial Roads. They typically allow for higher speeds and less access to surrounding properties than Minor Collectors.

### 4. Local Streets

These roadways account for the largest percentage of all roadways in terms of mileage. They are not intended for long distance travel. General use is at the origin or destination end of a trip, due to their provision of direct access to abutting land. They are typically designed to discourage through traffic.

### 5. Alleys

These roadways are intended to serve very slow speeds and volumes associated with the rear access and service functions for residential and commercial properties.

### 6. Private Streets

These roadways provide access to one or more lots but are not owned, operated and maintained by the City.

## 2.020.02 Cross Sections

Typical features and dimensions of standard City streets are listed in [Table 2.2](#). These standard sections may be revised by the City Engineer on a case-by-case basis, to meet

## Section 2 Design Requirements for Transportation Facilities

specific needs that may exist, or are projected to exist, along a particular street section. The following table summarizes for each standard section the primary design elements and their dimensions.

<b>Street Typical Cross Section Elements by Classification</b>						
Street Type	Right-of-Way	Travel Lanes	Bike Lanes	Sidewalks	Multi-Use Path	Parking Lane
Minor Arterial	90'	Four @ 12'	Two @ 5'	Two @ 6'	No	No
Minor Arterial	90'	Four @ 12'	No	One @ 6'	One @ 12'	No
Major Collector	90'	Four @ 12'	Two @ 5'	Two @ 6'	No	No
Major Collector	90'	Four @ 12'	No	One @ 6'	One @ 12'	8' Parking Allowed
Minor Collector	75'	Three @ 12'	Two @ 5'	Two @ 6'	No	8' Parking Allowed
Minor Collector	75'	Two @ 12'	No	One @ 6'	One @ 12'	8' Parking Allowed
Local Industrial	70'	Two @ 12'	No	One @ 6'	One @ 12'	8' Parking Allowed
Local Industrial	70'	Two @ 12'	No	Two @ 6'	No	8' Parking Allowed
Local Commercial	60'	Two @ 12'	No	One @ 6'	One @ 12'	8' Parking Allowed
Local Commercial	60'	Two @ 12'	No	Two @ 6'	No	8' Parking Allowed
Local Residential	55'	Two @ 11'	No	One @ 6'	One @ 12'	8' Parking Allowed
Local Residential	55'	Two @ 11'	No	Two @ 6'	No	8' Parking Allowed
Alley	25'	One @ 18'	No	No	No	No

**Table 2.2**

### 2.020.03 Right-of-Way and Easements

#### 1. Right-of-Way

Minimum right-of-way widths shall be as shown in [Table 2.2](#). Topography, special design features and other factors may require widths greater than these minimums. The City Engineer shall have final review with determination of any additional right-of-way that is required for the design of a specific street segment.

#### 2. Easements

There are several types of street-related easements allowed in the City.

- A. Public Utility, Drainage and Access Easement that shall be approved for use by the City Engineer on a case-by-case basis.
- B. Public Utility and Drainage Easement that shall be approved for use by the City Engineer on a case-by-case basis.
- C. Public Access Easement that allows public access to use and cross the property.
- D. Public Drainage Easement for drainage purposes only.

## Section 2 Design Requirements for Transportation Facilities

- E. Sight Distance Easement that provides for the line of sight leaving the right-of-way onto private property.
  - F. Slope Easement that provides for slopes between the street right-of-way and adjacent property.
  - G. Temporary Construction Easement that may be used to provide adequate construction area in the construction of a street project.
3. Improvements in Right-of-Way
- It is the policy of the City to place all permanent public streets, traffic signals, equipment, traffic signs and street-related feature in public street right-of-way, with fee simple ownership by the City.
4. Additional Right-of-Way Widths on Existing Streets
- Developments that adjoin existing streets shall dedicate additional fee simple right-of-way, where necessary, to meet the minimum requirements for the functional classification of the existing street, or other dimensions as required by the City Engineer. This dedication shall be as follows:
- A. The entire right-of-way shall be provided where any part of the development is on both sides of the existing street.
  - B. When the development is located on only one side of the existing street, one half (1/2) of the required width of the right-of-way, measured from the center line of the existing roadway, shall be provided. If the development provides improvements to the existing roadway that shifts the centerline of the roadway, then the one half (1/2) of the required width of the right-of-way shall be measured from the new centerline of the roadway.
  - C. When required by the City Engineer, additional right-of-way shall be required to accommodate future roadway improvements.
5. Dedication Process
- The dedication of right-of-way and easements for street purposes shall normally occur through the platting process. When dedications are required outside the platting process, they shall be dedicated in a manner and format approved by the City Engineer and Corporate Council.

## 2.030 Design Criteria

The design criteria presented in this Section apply to all roadways that are required to be designed and constructed to City standards and specifications. The design criteria presented below shall be used as minimum requirements for new developments and may be increased at the direction of the City Engineer if warranted by safety hazards or traffic operations.

The City Engineer, in consultation with other City departments and State agencies, may allow modifications to the design criteria set forth in this Section. Modifications may be necessary to allow private or public construction to be compatible with in-place improvements or to address unusual circumstances that justify an alternative design or criteria. Modifications to design criteria may be allowed provided that an investigation by the City Engineer concludes that all of the following criteria can be satisfied.

- The modification to the design criteria is based on sound engineering principles and practices.
- The modification to the design criteria will not create an unsafe or hazardous situation to occur.
- The modification to the design criteria will be equivalent to the minimum criteria set forth herein in terms of functionality, efficiency, durability, structural integrity and long-term maintenance.
- The modification to the design criteria will not adversely impact adjacent properties or individual property owners, provided that safety is not compromised.

The City Engineer is authorized to require studies or other pertinent information to be provided by the petitioner to help support or validate the modification request at no cost to the City.

All streets are to be designed in accordance with the design speeds specified for each street classification in this Section, or as amended by the City Engineer, and as summarized in [Table 2.3](#) and [Table 2.4](#).

### 2.030.01 Desired Operating Levels of Service

It is the policy of the City to design street segments and intersections to operate at a Level of Service "D" or better during the routine peak traffic loading conditions to the system. Lanes used for turning movements within intersections shall maintain at least a LOS "D". Should these levels of service not be achievable due to verifiable constraints, the City Engineer shall have final approval on the street design requirements necessary to attain the optimal operating and safety conditions available given the specific circumstances of a street or intersection location. Should these levels of service not be achievable, even with additional improvements, the Planning Commission and the City Council shall be presented the attainable levels of service. The development will be subject to approval or disapproval by the City Council based on substandard levels of service.

### 2.030.02 Design Traffic Levels

Streets shall generally be designed to accommodate projected future traffic conditions a minimum of twenty (20) years (or another target year agreed to in the Transportation

## Section 2 Design Requirements for Transportation Facilities

Impact Analysis Memorandum of Understanding (MOU)) after the street is opened to traffic. These projected traffic conditions shall address total daily traffic loads along with directional distribution of the peak-hour loads. These loads shall address typical weekday conditions as well as off-peaks and weekend periods when applicable. Season and special event conditions shall also be considered where appropriate as determined by the City Engineer.

### **2.030.03 Design Vehicle**

All streets shall be designed to accommodate the predominant type and composition of vehicles that can be reasonably expected to travel through them. At a minimum, for streets and intersections designed in the City, the vehicle types in [Table 2.5](#) shall be accommodated in the design process. For special circumstances other design vehicles may be required by the City Engineer.

### **2.030.04 Minimum Turning Paths of Design Vehicles**

All street and intersection geometric designs shall be evaluated to ensure that the minimum turning paths for the selected design vehicles can be safely and efficiently accommodated by the proposed street and intersection geometry.

### **2.030.05 Design Speed**

There are two primary types of speeds that must be considered in the street design process. The first is “design” speed, which is the selected speed used to determine the minimum geometric design features of the street. The second type is “operating” speed, which is the speed at which drivers operate their vehicles in free-flow conditions. The “85<sup>th</sup> percentile speed” (the speed at which 85 percent of the vehicles travel at or less) is generally assumed to be the operating (and typically posted) speed of a street.

The design speed selected for street design purposes shall take into consideration several factors including street classification, adjacent land use, topography and

distance, pedestrian and bicycle activity, and the desired operating speed of the facility. The design speed used in street design shall be approved by the City Engineer and shall generally be in accordance with [Table 2.4](#) for desirable design speed by street classification.



STREET STANDARDS - GENERAL PARAMETERS												
Design Feature or Characteristic	Minor Arterial		Major Collector		Minor Collector		Local Industrial		Local Commercial		Local Residential	
	90'	90'	90'	90'	75'	75'	70'	70'	60'	60'	55'	55'
Right of Way (ROW) Width	90'	90'	90'	90'	75'	75'	70'	70'	60'	60'	55'	55'
No. of Travel Lanes	4	4	4	4	3	3	2	2	2	2	2	2
Minimum Lane Width	12'	12'	12'	12'	12'	12'	12'	12'	12'	12'	12'	11'
Minimum Lane Width (total)	48'	48'	48'	48'	36'	36'	24'	24'	24'	24'	24'	22'
Median Width												
Curb & Gutter:												
Vertical or Mountable	V	V	V	V	V	V	V	V	V	V	V	V/M
Designated Bike Lanes	Yes	No	Yes	No	Yes	No	No	No	No	No	No	No
Bike Lane Width per side	5'	n/a	5'	n/a	5'	n/a	n/a	n/a	n/a	n/a	n/a	n/a
Parking Lane Width	n/a	n/a	n/a	8'	8'	8'	8'	8'	8'	8'	8'	8'
Minimum Sidewalk Width	6'	(1 side)	6'	(1 side)	6'	(1 side)	6'	(1 side)	6'	(1 side)	6'	(1 side)
Multi-Use Path	No	12'	No	12'	No	12'	No	12'	No	12'	No	12'
Grass Strip Width	6'	(1 side)	6'	(1 side)	6'	(1 side)	6'	(1 side)	6'	(1 side)	6'	(1 side)
Left Turn Lanes Req'd?	Yes	Yes	Yes	Yes	Yes	Yes	Yes	Yes	Yes	Yes	Yes	Yes
Right Turn Lanes Req'd?	Yes	Yes	Maybe	Maybe	No	No	No	No	No	No	No	No
Traffic Volume Capacity (1000 veh/day)	5-15	5-15	1.5-5	1.5-5	0.5-1.5	0.5-1.5	<1	<1	<1	<1	<0.5	<0.5
Speed Limit, MPH <sup>a</sup>	40	40	35	35	30	30	25	25	25	25	25	25
Driveway & Street Access	Limited	Limited	Limited	Limited	Frequent	Frequent	Unlimited	Unlimited	Unlimited	Unlimited	Unlimited	Unlimited
Continuity of Travel	High	High	Moderate	Moderate	Low	Low	Very Low	Very Low	Very Low	Very Low	Very Low	Very Low
Street Lights	Yes	Yes	Yes	Yes	Yes	Yes	Partial	Partial	Yes	Yes	Partial	Partial
Traffic Calming	None	None	None	None	Possible	Possible	Possible	Possible	Possible	Possible	Possible	Possible

NOTES: a. Design speed shall be a minimum of 5mph above the posted speed limit.

Table 2.3

STREET STANDARDS - TECHNICAL DESIGN CRITERIA										
Design Element	Arterial		Collector		High Volume <sup>e</sup>	Local		Low Volume	Alley	
	Major	Minor	Major	Minor		Intermediate Volume	Volume		Alley	
<b>Overall Design Parameters</b>										
Design Speed/Posted Speed	50/45	45/40	40/35	35/30	30/25	25/25	25/25	25/25	15/15	
Min Stopping Sight Distance <sup>a</sup>	425'	360'	305'	250'	200'	155'	115'	80'		
Passing Sight Distance	1,835'	1,625'	1,470'	1,280'	n/a	n/a	n/a	n/a	n/a	
<b>Horizontal Alignment<sup>b</sup></b>										
Minimum centerline radius:	with no super-elevation (NC)	1,391'	1,039'	762'	510'	333'	150'	70'	55'	
	with 0.02 super-elevation	1,011'	794'	593'	408'	Not Allowed	Not Allowed	Not Allowed	Not Allowed	
	with 0.04 super-elevation	905'	711'	533'	371'	Not Allowed	Not Allowed	Not Allowed	Not Allowed	
Maximum super-elevation	0.04 ft/ft	0.04 ft/ft	0.04 ft/ft	0.04 ft/ft	n/a	n/a	n/a	n/a	n/a	
Minimum tangent between curves or at intersections	200'	150'	150'	100'	100'	0	0	0	0	
<b>Vertical Alignment</b>										
Maximum Centerline Grade %	6	7	8 <sup>c</sup>	8 <sup>c</sup>	8 <sup>c</sup>	10 <sup>c</sup>	10 <sup>c</sup>	10 <sup>c</sup>	8	
Minimum Gutter Flow-line Grade %	0.5	0.5	0.5	0.5	0.5	0.5-1.0	0.5-1.0	0.5-1.0	1	
Min. K-values for Vertical Curves (Stopping Sight Distance)	Crest	84	61	44	29	19	12	7	7	
	Sag	96	79	64	49	37	26	17	17	
<b>Access Management</b>										
Distance Between Intersections	Signalized	2,640'		1,320'	1,320'	n/a	n/a	n/a	n/a	
	Non-Signalized	1,200'	600'	300'	300'	200 <sup>d</sup>	200 <sup>d</sup>	200 <sup>d</sup>	200 <sup>d</sup>	
Minimum distance between high volume driveways/alleys & street intersections	800'	600'	300'	300'	200'	200'	200'	200'	n/a	
Minimum distance between low volume driveway edges	250'	250'	150'	150'	150'	20'	20'	20'	10'	
Minimum corner clearance between low volume driveway edges & street intersections	250'	250'	230'	125'	50'	50'	50'	50'	40'	
Driveway width (two-way)	25' - 36'	25' - 36'	25' - 36'	25' - 36'	25' - 36'	25' - 36'	10' - 20'	10' - 20'	n/a	
Driveway approach configuration	Radius Return	Radius Return	Radius Return	Radius Return	Radius Return	Radius Return	Curb Cut	Curb Cut	Radius Return	

**NOTE:**

- a. AASHTO "Green Book" latest standards supersede these requirements and shall be adjusted based on roadway grades.
- b. AASHTO "Green Book" latest standards supersede these requirements. Requirements based on Low-Speed Urban Streets.
- c. These dimensions may be increased or amended by the City Engineer as deemed necessary for safe and efficient street operations.
- d. These distances may be reduced to 125 feet when both intersecting streets are cul-de-sacs.
- e. This category is used for Local Industrial and Commercial Streets

**Table 2.4**

<b>Design Vehicle Requirements</b>	
Street Classification	Vehicles Accommodated
Alley	Passenger cars and single-unit trucks.
Local	Passenger cars, single-unit trucks (SU-30), and conventional school buses must be able to turn easily from one street to the next and remain in the correct lane for each street. Combination trucks (WB-50) shall be able to physically traverse local streets by using the full width of the traveled way if necessary, including intersection turns, and without tracking onto the curb at corners.
Local Commercial	Passenger cars, transit buses (S-40), single-unit trucks, conventional school buses and combination trucks (WB-62) must be able to turn easily from one street to the next and remain in the correct lane for each street, and without tracking onto the curb at corners.
Local Industrial	Passenger cars, transit buses (S-40), single-unit trucks, conventional school buses and combination trucks (WB-62) must be able to turn easily from one street to the next and remain in the correct lane for each street, and without tracking onto the curb at corners.
Minor Collector	Passenger cars, single-unit trucks (SU-30) and conventional school buses must be able to turn easily from one street to the next and remain in the correct lane for each street. Combination trucks (WB-50) shall be able to physically traverse the street by using the full width of the traveled way if necessary, including intersection turns, and without tracking onto the curb at corners.
Major Collector	Passenger cars, transit buses (S-40), single-unit trucks, conventional school buses and combination trucks (WB-62) must be able to turn easily from one street to the next and remain in the correct lane for each street, and without tracking onto the curb at corners.
Major and Minor Arterial	Passenger cars, transit buses (S-40), single-unit trucks, conventional school buses and combination trucks (WB-67) must be able to turn easily from one street to the next and remain in the correct lane for each street, and without tracking onto the curb a

**Table 2.5**

**2.030.06 Street and Lane Widths**

1. Street Widths

The minimum width of a street pavement section shall be determined by its functional classification. Other elements such as topography, special requirements identified in Circulation Plans and Transportation Impact Analysis (such as turn lanes and deceleration/acceleration lanes), and unique street design features may necessitate a change in the minimum street section width. The City engineer will approve the final required street width.

2. Lane Widths

The minimum and desirable widths of different types of lanes based on the street classification are provided in [Table 2.3](#). These widths may be modified by the City Engineer based on the specific requirements of a street section.

**2.030.07 Special Street Configurations**

1. Cul-de-Sacs

A. Where Allowed: Cul-de-sacs are permitted only on Local Street classifications

## Section 2 Design Requirements for Transportation Facilities

and shall not extend for more than 500 feet (unless necessitated by topography and approved by the City Engineer) as measured from the center of the cul-de-sac turn around to the nearest right-of-way boundary of the adjoining street right-of-way intersection. This length may be extended to 1,000 feet with approval of the Fire Chief. In no case shall a cul-de-sac or temporary dead-end street serve more than twenty (20) single-family residential lots.

- B. Secondary Access: Any Local Street with a cul-de-sac that exceeds the maximum lengths above shall be provided with a secondary access point.
- C. Design Requirements: Cul-de-sac streets shall terminate in a circular turn around having a right-of-way radius of at least 65 feet, and a paved radius of at least 50 feet at its outside edge.
- D. Prohibited Designs: All cul-de-sac designs must allow for automobiles and typical service vehicles to turn around without requiring backing maneuvers.
- E. Temporary Cul-de-Sac: Where development is being implemented by sections, a temporary cul-de-sac may be used if the overall development plan allows the cul-de-sacs to be eliminated at final build out of the development. Temporary cul-de-sacs shall be replaced with a street connection within three (3) years or less from the date construction starts unless otherwise approved by the Fire Chief. The cul-de-sac shall be provided with an asphalt or concrete turn-around having a radius of at least 50 feet. No designs requiring backing maneuvers will be allowed. The easement radius shall be a minimum of 65 feet in areas where there is no adjacent public utility and access easement, and a minimum of 60 feet where public utility and access easements are required and/or provided.

All temporary cul-de-sacs shall be constructed within dedicated street right-of-way or a dedicated Public Utility, Drainage and Access Easement for those areas outside the tangent street right-of-way section. The Easement outside the tangent right-of-way section shall be vacated by the City when the Easement is no longer necessary. Application for vacation of the easement must be initiated and paid for by the Developer or property owner.

A sign must be provided at the end of the temporary cul-de-sac noting that the street will be extended in the future.

- F. Cul-de-Sac Parking: Parking in a cul-de-sac is typically discouraged in order to allow adequate room for emergency and service vehicles to maneuver. If parking is proposed in the cul-de-sac, a plan shall be submitted to the City Engineer demonstrating that parked vehicles will not impede movements

## Section 2 Design Requirements for Transportation Facilities

contemplated to be made by emergency vehicles. When on-street parking is allowed, the minimum cul-de-sac dimensions shall normally be increased by a minimum of eight (8) feet.

### 2. Eyebrows

- A. Where allowed: Eyebrows shall be permitted only on Local Streets. They may only be used in tangent sections or at intersection corners to improve accessibility to odd-shaped sites. Design of eyebrows shall be as shown in [Figure 2.1](#).

- B. Design requirements:  
Eyebrows shall be a minimum of twenty-five (25) feet in length and a maximum of fifty (50) feet measured along the flowline. Lengths exceeding fifty (50) feet shall incorporate an island as approved by the City Engineer. Designs that require backing maneuvers for typical use vehicles are prohibited.



Typical Eyebrow

- C. Location: The location of the eyebrow shall be in conformance with intersection spacing requirements as provided in [Section 2.030.23, Access Management & Design](#).

### 3. Dead-End Streets

- A. Where allowed: Permanent dead-end streets without cul-de-sac designs are prohibited.
- B. "Stub" Streets: Temporary dead-end "stub" streets (without temporary cul-de-sacs) will only be permitted on Local Streets at the discretion of the City Engineer. On residential local streets, "stub" streets shall not be longer than on residential lot.

Section 2 Design Requirements for Transportation Facilities

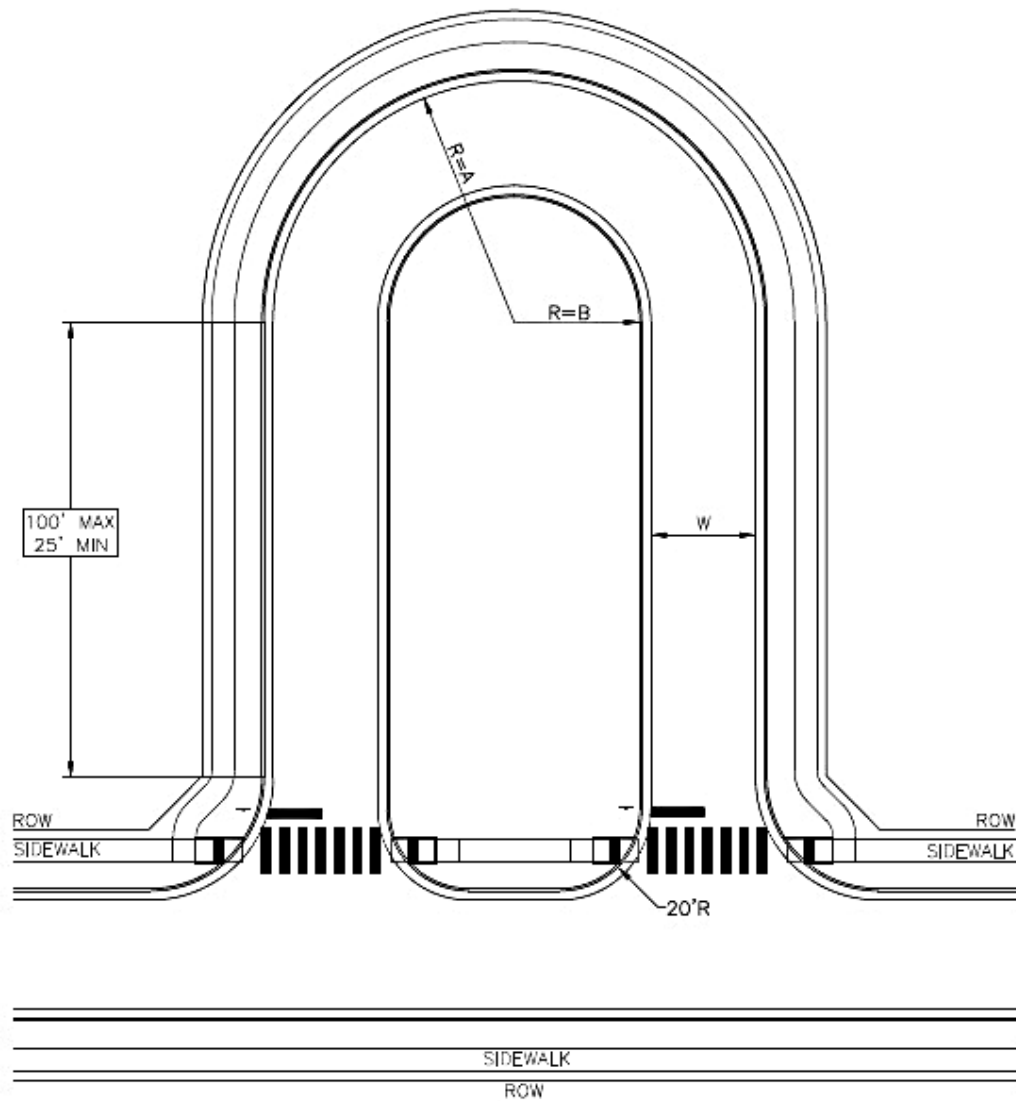

STREET CLASSIFICATION	RADIUS (MIN.)		NO PARKING W	PARKING	
	A	B (MAX)		ONE SIDE W	TWO SIDES W
LOCAL SINGLE FAMILY RESIDENTIAL	55'	30'	15'	23'	31'
LOCAL MULTIFAMILY RESIDENTIAL	60'	30'	22'	30'	38'
LOCAL COMMERCIAL & INDUSTRIAL	65'	26'	24'	32'	38'

- 1) THE SIDEWALK AROUND THE EYEBROW SHALL BE PLACED ACCORDING TO THE STREET CLASSIFICATION. THE SIDEWALK ACROSS THE STREET END OF THE ISLAND IS TO BE PLACED IN THE SAME LOCATION AS ON THE CROSS STREET.
- 2) MEDIAN MAY BE LANDSCAPED OR HARDCAPED AS REQUIRED AND SHALL BE MAINTAINED BY THE OWNERS ASSOCIATION.
- 3) WHEN PARKING IS RESTRICTED TO ONE SIDE, IT SHALL BE PROVIDED ON THE OUT-SIDE OF THE STREET.

Figure 2.1

## Section 2 Design Requirements for Transportation Facilities

- C. Signs Required: A sign must be provided at the temporary street end noting that the street will be extended in the future.

### 4. Half Streets

The City Engineer may allow the construction of half streets on Minor Collector and Local streets when only one side of a street right-of-way is available. A minimum of 22 feet of pavement must be provided on any half street. In such cases, the property owner is responsible for right-of-way dedication and construction of the half of the new street section that is adjacent to their property. These partial street sections will be built to permanent street standards including all curb and gutter, drainage, sidewalks and other elements as called for in the typical section for that street classification. Additional dedication of street easement may be required by the City Engineer in these cases.

### 5. Provisions for Future Public Street Intersections

Where provisions are to be made to intersect a future side street with the street being designed, the curb radii and pavement section of the future intersecting street "stub" shall typically be built to the end of the radii curb return. If the expected construction of the future street connection is anticipated to occur more than three (3) years after the primary street is constructed, then the street approach "stub" may be omitted and temporary curb, gutter and sidewalk improvements provided through this Section. In such cases, the curb and gutter shall be concrete while the temporary sidewalk or path may be asphalt.

### 6. Improvement of Annexed Streets

Streets annexed into the City may be required to meet these engineering standards before they are accepted as City streets. The City Engineer shall evaluate all proposed street annexations to determine their adherence to these standards, and any recommendations for improvements to meet minimum public safety, health and welfare requirements.

## **2.030.08 Horizontal Alignment**

The design of horizontal curves in street design shall be based on an appropriate relationship between design speed and curvature and on their joint relationships with superelevation and side friction. On Arterial and Major Collector streets curve radii and tangents shall be as large as possible using the minimums only where necessary. However, minimum radius curves shall be used on Local and Minor Collector streets unless otherwise required. Angle point direction changes are not allowed. All changes in direction shall be made using standard curves.

### 1. Horizontal Curve Radii

The minimum allowable centerline radii for horizontal curves shall be as designated

## Section 2 Design Requirements for Transportation Facilities

in [Table 2.4](#). Reverse and compound curves shall be used only when a single radius curve will not work. For driver safety, compound curves shall preferably have a ratio no greater than 1:1.5 where the value of the larger radius is divided by the smaller radius. When they are designed, IDOT Standard Specifications and AASHTO's "Green Book" design standards and procedures shall be used.

Based on typical conditions in the City, the absolute minimum and desirable horizontal curves for streets without superelevation are shown in [Table 2.4](#). This table also provides the minimum tangent distance between reverse curves.

The effect of grade shall also be considered by the designer when selecting horizontal curvature. The design of more complex horizontal curve geometry shall be conducted in accordance with IDOT Standard Specifications, AASHTO's "Green Book" and AASHTO's "Guidelines for Geometric Designs of Very Low-Volume Local Roads (ADT ≤ 400)".

### 2. Minimum Tangent Length

- A. **Intersection:** Whenever a minor street intersects a street of higher classification, a tangent length (measured from the nearest gutter flow-line of the intersected street to the point of curvature in the intersecting street) shall be provided for a safe sight distance and safe traffic operation. The minimum required tangent lengths indicated in [Table 2.4](#) apply to the minor leg(s) only. The angle of departure shall not exceed ten (10) degrees for the length of the tangent.
- B. **Reverse Curves:** Reverse curves in streets shall be separated by minimum tangents of between two hundred (200) and one hundred (100) feet for Arterial and Major Collector streets as shown in [Table 2.4](#).
- C. **Broken Back Curves:** Two curves in the same direction (broken back curves) shall be separated by a tangent with a length of at least two times the minimum length shown in [Table 2.4](#).

### 3. Curves with Small Deflection Angles (10° or less)

To reduce the appearance of kinks in the street, minimum lengths of curve shall be designed with minimum arc lengths as shown in [Table 2.6](#).



<b>Minimum Centerline Arc Length</b>	
Street Classification	Minimum Centerline Arc Length (ft)
Local - Residential	100
Local - Commercial & Industrial	200
Minor Collector	250
Major Collector - Residential	250
Major Collector - Commercial & Industrial	300
Minor Arterial	300

**Table 2.6**

4. **Horizontal Curves on Vertical Curves**  
 For driver safety, horizontal curves shall not begin near the top of a crest vertical curve nor near the bottom of a sag vertical curve.
  
5. **Off-Site Design Centerline, Flowlines and Cross-Sections**  
 To assure that future street improvements will meet these Standards, the centerline, flowline, and cross-sections of all streets, except cul-de-sacs, shall be continued for five hundred (500) feet beyond the proposed construction. The grade and ground lines of all arterials shall be continued an additional five hundred (500) feet for a total of one thousand (1000) feet beyond the end of the proposed construction.
  
6. **Joining Existing Improvements**  
 Connection with existing streets shall be made to match the existing alignment grade of the existing improvements, in accordance with horizontal alignment criteria.
  
7. **Cross Slope**
  - A. **Minimum Cross Slope:** A minimum cross slope on all new streets and on reconstruction or overlays is one and one-half (1.5) percent. All other values of cross slope shall be independently reviewed and approved by the City Engineer.
  
  - B. **Maximum Allowable Cross Slope:** Maximum allowable tangent cross slope on all new construction shall be two (2.0) percent. Maximum allowable cross slope on any reconstruction or overlays of existing streets shall be four (4.0) percent.
  
  - C. **Cross Slope for Street Modifications:** When widening an existing street or adding turn lanes to an existing street, the resulting cross slope of the widened portion shall be within the limits stated above and the new Cross Slope shall be no less than the existing cross slope. However, if the cross slope of the existing street exceeds the Standards, then new curb and gutter shall be designed such

## Section 2 Design Requirements for Transportation Facilities

that the existing pavement, when overlaid, will result in a straight-line cross slope grade that meets these Standards. Alternatively, the existing pavement may be removed and re-profiled to comply with these Standards.

- D. **Cross Slope for Cul-de-Sacs:** Cul-de-sac cross slopes shall not be less than one and one-half (1.5) percent nor more than five (5.0) percent, with two (2.0) being desirable.

### 8. Superelevation on Horizontal Curves

The purpose of superelevating a street is to maintain the riding comfort on horizontal curves. Superelevation is not typically used on streets in the City with design speeds at or less than 30 MPH. For design speeds higher than 30 MPH or where superelevation is required or preferred, IDOT's "*Bureau of Local Roads and Streets Manual*" and AASHTO's "*Green Book*" design standards and procedures shall be used. The following criteria shall be followed:

- A. **Where Superelevation is Permitted:** Superelevation may be allowed for curves on arterial and collector streets. In no case shall superelevation exceed four (4.0) percent cross slopes. As specified in [Table 2.4](#), superelevation shall not be used on local streets.
- B. **Transition Length:** When superelevation is used, use the IDOT method with the transition length distributed 75-percent on tangent and 25-percent on the curve.
- C. **Drainage:** Where superelevation is used, the gutter shall always be an inflow type. The water must enter a storm sewer system or other acceptable outlet from the street rather than crossing the street in sheet flow. Where medians are present in a super-elevated section, water may be allowed to sheet flow from the median to the street gutter.

### 2.030.09 Vertical Alignment

The design of vertical curves in street design shall be simple in application and shall result in a design that is safe and comfortable in operation, pleasing in appearance and adequate for drainage.

#### 1. Maximum and Minimum Grades for Streets

The maximum and minimum grades for specific street classifications are shown in [Table 2.4](#). The centerline grade in the bulb of a cul-de-sac shall not exceed five (5.0) percent.

## Section 2 Design Requirements for Transportation Facilities

### 2. Grade Breaks

No single point shall exceed four tenths (0.40) percent, except for the flow line in sag curves where the maximum grade break is (1.0) percent. In curb returns, a grade break may be as great as three (3.0) percent for extreme circumstances.

### 3. Minimum Flow-line Grades

Minimum flow-line grades for gutters shall be one-half (0.50) percent, except in the bulb of cul-de-sacs where the minimum shall be one (1.0) percent.

### 4. Grades Through Intersections

The profile grade lines on the legs of an intersection shall be adjusted for a distance back from the intersection to provide a smooth junction and proper drainage. Normally, the grade line of the major street shall be carried through the intersection and that of the minor street shall be adjusted to it. Any changes in profile through an intersection shall meet the crest and sag curve criteria noted below, to the extent deemed practical. The City Engineer shall approve all variations from these criteria. Intersection approach grades shall consider the deceleration and acceleration that occurs due to traffic control and turning movements. It is desirable to provide near level intersection approach grades to improve operations and safety within the intersection area. Maximum intersection approach grades are shown in [Table 2.7](#).

<b>Minimum Centerline Arc Length</b>		
Classification	Maximum Grade	Maximum Grade Approaching Signalized Intersection
Major Arterial	6%	2% for 500 ft.
Minor Arterial	7%	2% for 500 ft.
Major Collector Commercial/Industrial	8%	3% for 400 ft.**
Major Collector Residential	10%	3% for 300 ft.
Minor Collector	10%	3% for 300 ft.
Local Commercial/Industrial	8%	4% for 200 ft.**
Local Residential*	14%*	4% for 100 ft.
Cul-de-Sac	5%	n/a
Alley	8%	n/a

\*Maximum desirable grade is 10% unless existing conditions justify the use of a higher grade. When a higher grade is proposed, it must be approved by the City Engineer to ensure ease of service for emergency and service vehicles.

\*\*Concrete pavement may be required to maintain acceptable pavement conditions on steep sections.

**Table 2.7**

## Section 2 Design Requirements for Transportation Facilities

### 5. Requirements for Using Vertical Curves

The major control for safe operation on “crest” vertical curves is the provision of ample sight distance for the design speed. Crest vertical curves shall be designed to at least provide the minimum stopping sight distance as established in AASHTO’s “Green Book”.

The design of “sag” vertical curves is controlled by headlight distance, passenger comfort, drainage control and general street appearance. At under-crossings the structure may limit sight distance which could cause the need for higher K factors to achieve adequate stopping sight distance.

### 6. Joining Existing Improvements

Connection with existing streets shall be made to match the existing grade of the existing improvements, in accordance with vertical alignment criteria (grade breaks shall not exceed allowable).

### 7. Vertical Clearance

Vertical clearance above a street shall be a minimum of sixteen and one-half (16.5) feet. The City Engineer may require greater clearance when considered necessary to meet future street operation requirements.

### 8. Off-Site Continuance of Grade and Ground Lines

To assure that future street improvements will meet these Standards the grade and ground lines of all local and collector streets, except cul-de-sacs, shall be continued on the plans for five hundred (500) feet beyond the proposed construction. The grade and ground lines of all arterials shall be continued one thousand (1000) feet beyond the end of the proposed construction.

### 9. Coordinating Horizontal and Vertical Alignments

Horizontal and vertical design shall not be designed independently. Horizontal alignment and profile are among the more important design elements of a street. Their effective combination increases safety, encourages uniform speed, and improves appearance. Some general guidelines for their relationships are:

- A. Curves and grades shall be in proper balance. The designer shall not combine extreme horizontal and/or vertical conditions or introduce significant curves at the end of long tangent sections or flat grades.
- B. Sharp horizontal curvature shall not be introduced at or near the top of a pronounced crest vertical curve, nor shall it be introduced near the bottom of a steep grade approaching or near the low point of a pronounced sag vertical

## Section 2 Design Requirements for Transportation Facilities

curve.

- C. Both horizontal and vertical curvature and profile shall be made as flat as practical at intersections where sight distance along both streets is important and vehicles may have to slow or stop.
- D. Designers should begin evaluating horizontal alignment and profile in the preliminary design stage. Proposed alignment and profile shall be submitted to the City for review and comment prior to advancing the design process.

### 2.030.10 Sight Distance

#### 1. General

Sight distance calculations shall be based on AASHTO's "*Green Book*" requirements.

All streets designed in the City shall provide adequate sight distance for all types users, considering both horizontal and vertical alignment. Sight distance shall be carefully considered in the preliminary stages of design when both the horizontal and vertical alignment may still be subject to adjustment.

#### 2. Sight Obstructions

Any object within a sight distance triangle more than twenty-four (24) inches above the flow-line elevation of the adjacent street shall constitute a sight obstruction and shall be removed or lowered. Such objects include but are not limited to berms, buildings, parked vehicles on private property, cut slopes, hedges, trees, shrubs, mailbox clusters, utility cabinets or tall crops. Since vehicles parked on-street are under the control of the City, parked vehicles shall not be considered an obstruction for design purposes. The City may limit parking to protect visibility when needed. The sight distance shall be measured to the approach lane position as shown in [Figure 2.2](#). In no case shall any permanent object encroach into the line-of-sight of any part of the sight distance triangle. Street trees within the sight distance easement may be excepted from this requirement if pruned up to eight (8) feet, and the trunks at maturity do not collectively hinder sight lines as determined by the City Engineer. The shaded portion of the diagram depicts the sight triangle area where site element heights and locations are strictly limited.

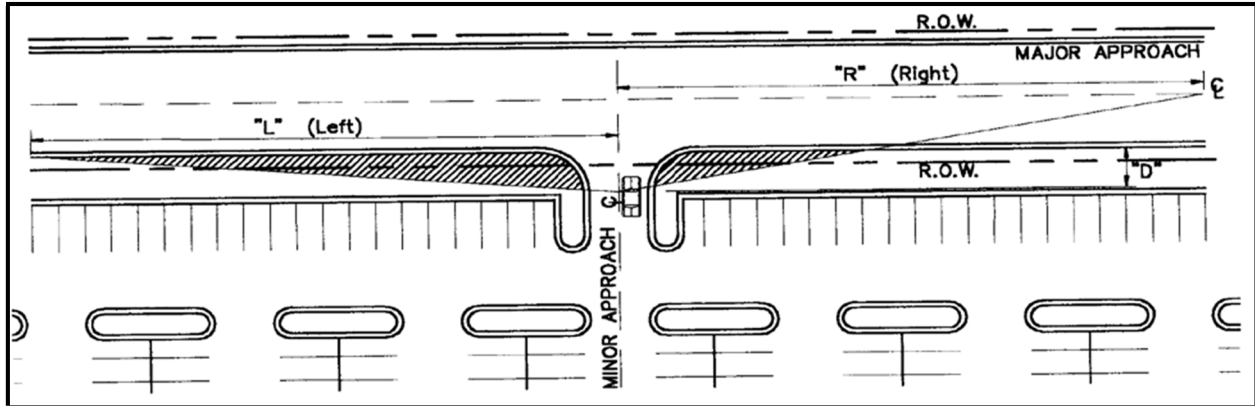

Intersection Sight Distance Triangle

**Figure 2.2**

During the street design process, the designer shall identify and correct for any sight obstructions that could limit the driver's sight distance beyond the distances noted above. This process shall investigate both the vertical and horizontal plane for sight obstructions. No landscaping or hardscaping shall be permitted within a corner area that will block the line of sight for pedestrian visibility (not higher than twenty-four (24) inches and possibly less depending on street geometry).

Street intersections shall be designed so that adequate sight distance is provided along all streets. The required sight distance shall be determined by the design speed and grades of the street and the acceleration rate of an average vehicle. In addition, for all streets that intersect with Arterial and Collector Streets, the sight distance must be large enough to allow a vehicle to enter the street and accelerate to the average running speed without interfering with the traffic flow on the Arterial or Collector Street. Intersection sight distance is generally determined based on the different types of traffic control at an intersection. In most cases sight distance triangles will be required as described below. The different situations, or cases, that must be considered are defined in the following discussion.

3. Sight Distance Easements

All sight distance easements must be shown on the street plan/profile plans. All necessary sight distances must be within the public right-of-way or a sight distance easement dedicated to the City. When the line of sight crosses onto private property, a "Sight Distance Easement" shall be dedicated to the City; however, maintenance shall be the responsibility of the property owner or the appropriate home owners association (HOA).

### 2.030.11 Lane Transitions

Lane transitions are necessary when through lanes require lateral transitions without the use of horizontal curves. Also, when constructing a street that will directly connect with an existing street of different width, it is necessary to install a transition taper between the two. The length of taper depends on the lateral offset distances between the outside traveled edge of the two sections and the design speed of the roadway. Formulas for determining transition taper lengths are shown below:

$$\text{For speeds } \leq 40 \text{ mph: } L = \frac{W * S^2}{60}$$

$$\text{For speeds } > 40 \text{ mph: } L = W * S$$

L = transition taper length, feet

W = width of pavement offset, feet

S = roadway design speed, mph

When transition tapers are located on a curve, the separate halves of the roadway shall be designed with different curves to create the taper without any angle points in the curvature.

### 2.030.12 Auxiliary Lanes

Auxiliary through lanes may be required along sections of any arterial or collector street to address existing or projected capacity or safety issues, at the determination of the City Engineer.

### 2.030.13 Intersections

Intersections shall be designed to provide for the safety of motorists, pedestrians, and bicyclists. Designs shall be based on criteria from the ITE's *"Traffic Engineering Handbook"* and AASHTO's *"Green Book"*.

#### 1. Basic Intersection Design

By their nature, intersections are conflict locations. Vehicles, pedestrians, and bicycles cross paths. Each crossing is a conflict point. Intersection contain many conflict points. The basic design of intersections includes the following objectives:

- Minimize points of conflict;
- Simplify areas of conflict;
- Limit conflict frequency; and

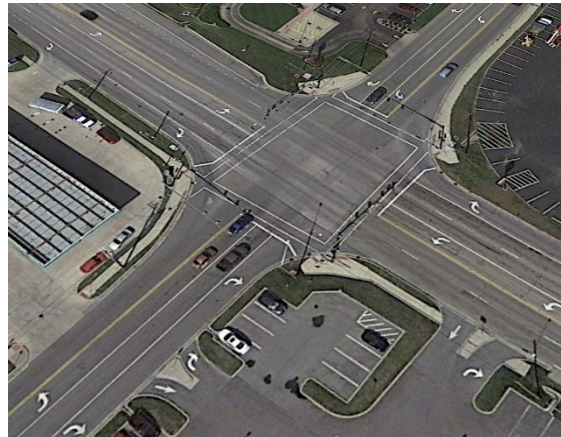

## Section 2 Design Requirements for Transportation Facilities

- Limit conflict severity
2. Minimum Number of Intersection Turn Lanes  
Intersections planned and constructed in the City shall allow for a minimum number of turn lanes to provide acceptable levels of traffic operations. [Table 2.8](#) identifies the minimum number of turn lanes to be provided at typical arterial, collector and local street intersections. The City Engineer may increase or decrease these requirements based on a transportation impact analysis or other relevant factors.
  3. Location of Intersections  
Intersections create turning movements and therefore conflict points in the traffic stream. It is therefore essential that they be carefully planned, located and designed to function effectively and safely. For intersection location criteria, refer to [Section 2.030.23, Access Management & Design](#).
  4. Spacing of Intersections  
Intersection spacing shall be determined based on a traffic circulation and operations analysis considering elements such as left and right turn lane requirements, traffic weaving movements, location of private access points, and traffic signal coordination. In no case shall these intersections be less than those shown in [Table 2.4](#). Street jogs and/or intersections on local streets of less than two-hundred (200) feet shall not be allowed, except where both intersecting streets are cul-de-sacs in which case the street jogs with centerline offsets of less than one hundred twenty-five (125) feet shall not be allowed.
  5. Lane Alignment  
All lanes shall be in alignment through each intersection, with a maximum of a two (2) foot shift in a hardship situation only, subject to approval by the City Engineer. Should a shift of greater than two (2) feet be allowed, special markings and signs may be required to support that shift design.
  6. Angle of Intersection  
Crossing streets shall intersect at ninety (90) degrees whenever possible. In no case shall they intersect at less than eighty (80) degrees or more than one-hundred (100) degrees.



Section 2 Design Requirements for Transportation Facilities

Typical Minimum Intersection/Interchange Requirements						
Class	Intersecting with A:					
	Minor Arterial	Major Collector	Minor Collector	Local Industrial	Local Commercial	Local Residential
<b>Major Arterial</b>	Separate Rights Double Lefts Possible Interchange	Separate Rights Double Lefts Possible Interchange	Separate Rights Double Lefts Possible Interchange	Should not connect	Possible Lefts on Collector	Should not connect
<b>Minor Arterial</b>	Separate Rights Double Lefts on Arterial	Separate Rights on Arterial Lefts on Collector	Separate Rights on Arterial Lefts on Collector	Should not connect	Possible Lefts on Collector	Should not connect
<b>Major Collector</b>	Separate rights Single lefts	Single lefts Possible separate rights Possible roundabout	Single lefts Possible separate rights Possible roundabout	Possible Lefts on Collector	Possible Lefts on Collector	Possible Lefts on Collector
<b>Minor Collector</b>	Separate rights Single lefts	Single lefts Possible separate rights Possible roundabout	Single lefts Possible separate rights Possible roundabout	Possible Lefts on Collector	Possible Lefts on Collector	Possible Lefts on Collector
<b>Local Industrial</b>	Should not connect	Possible lefts on Collector Possible roundabout	Possible lefts on Collector Possible roundabout	Possible roundabout	Possible roundabout	Possible roundabout
<b>Local Commercial</b>	Possible Lefts on Arterial	Possible lefts on Collector Possible roundabout	Possible lefts on Collector Possible roundabout	Possible roundabout	Possible roundabout	Possible roundabout
<b>Local Residential</b>	Should not connect	Possible lefts on Collector Possible roundabout	Possible lefts on Collector Possible roundabout	Possible roundabout	Possible roundabout	Possible roundabout

NOTE: It is assumed that, at a minimum, single left turn lanes will be provided at all public street intersections along major street, and will also be provided on any collector approach to an arterial street.

**Table 2.8**

## Section 2 Design Requirements for Transportation Facilities

### 7. Horizontal Alignment and Vertical Profile

- A. Horizontal: The horizontal alignment of streets through an intersection shall be designed in conformance with [Table 2.4](#). Intersections may be placed on horizontal curves, provided that the tangent lengths given in [Table 2.4](#) are provided on the minor street and the required intersection sight distance is met.
- B. Vertical: The street profile grade shall not exceed the percentages shown in [Table 2.7](#) for the approaches to the intersection, as measured along the centerline of the street. The profile grade within the intersection streets shall not exceed three (3) percent.
- C. Prevailing Street Grade: The grade of the street with the higher classification shall prevail at intersections. The lesser street shall adapt to the grade of the major street. Grading of adjacent property and driveways shall adapt to the street grades. When streets are of equal classification, the City Engineer shall determine which street grade prevails.

### 8. Exclusive Left Turn Lanes

Exclusive left turn lanes shall be provided on all arterial streets and other streets wherever left turn lanes are specified as needed by an access plan, required by these Specifications or warranted and approved by the City Engineer. The Designer shall use information in the transportation impact analysis, when available, to determine whether an exclusive left turn lane is warranted on non-arterial streets.

- A. At Signalized Intersections: A separate left turn lane shall be required unless otherwise determined by the City Engineer.
- B. At Unsignalized Intersections: Left turn lanes may be required at approaches to intersections for which the combination of through, left, and opposing volumes exceeds warrants as stated in a traffic analysis. The City Engineer will determine which peak hours to consider in this evaluation. The transportation impact analysis (TIA) shall make recommendations for the location and dimensions of all left turn lanes.
- C. Design Criteria: Left turn lanes shall be designed to provide the following functions:
  - (1) A means for safe deceleration outside the high speed through lane.
  - (2) A storage length long enough for left turning vehicles so that the signal phasing can be optimized and intersection delay minimized.
  - (3) A means of separating movements at unsignalized intersections to reduce

## Section 2 Design Requirements for Transportation Facilities

left turn impacts on other flows.

The design elements for a left turn lane are the approach taper, bay taper, length of lanes, width of lanes, and departure taper. For a graphical representation of bay taper and approach taper lengths, see [Figure 2.3](#). The required left turn lane widths shall be as specified in [Table 2.3](#). Other dimensions shall be as defined in the transportation impact analysis (TIA).

### 9. Exclusive Right Turn Lanes

Exclusive right turn lanes shall be provided at locations where they are specified as needed by an access plan, or where required by the applicable transportation impact analysis, approved by the City Engineer.

- A. Warrants for Right Turn Lanes: The transportation impact analysis (TIA) shall determine whether a right turn lane is to be provided at intersections or accesses.
- B. Design Criteria: Right turn lanes shall be designed to accomplish the following functions:
  - (1) Provide a means of safe deceleration outside the high speed through lane.
  - (2) Provide a separate storage area for right turns to assist in the optimization of traffic signal phasing.
  - (3) Provide a means of separating right turn movements at stop controlled intersections.

The design elements are the approach taper, bay taper, lengths of lanes, width of lanes, and departure taper. For approach taper lengths and other elements, see [Figure 2.4](#).



Pedestrian Refuge

- C. Pedestrian Refuge: Where pedestrian refuge is required between a right turn lane and through lanes, it shall be designed in accordance with [Figure 2.5](#).

## Section 2 Design Requirements for Transportation Facilities

### 10. Acceleration/Deceleration Lanes

For each high volume driveway and major intersection, acceleration/deceleration lanes shall be considered. The specific designs for these lanes shall be in accordance with the design for left and right turn lanes given above. *NCHRP Report 279* shall also be considered during the design process for additional guidance.

- A. Acceleration Lane Transition Tapers: The transportation impact analysis (TIA) shall determine the necessary distances for designing acceleration lane lengths and tapers, subject to approval of the City Engineer.
- B. Deceleration Lane Transition Tapers: The transportation impact analysis (TIA) shall determine the necessary distances for designing deceleration lane lengths and tapers, subject to approval of the City Engineer.
- C. Left Turn Approach and Bay Tapers: When left turn lanes are designed with lateral transitions, the formulas on [Figure 2.3](#) shall be used to compute the necessary distances, subject to approval of the City Engineer.
- D. Right Turn Approach and Bay Tapers: When right turn lanes are designed with lateral transitions, the formulas on [Figure 2.4](#) shall be used to compute the necessary distances, subject to the approval of the City Engineer.

Section 2 Design Requirements for Transportation Facilities

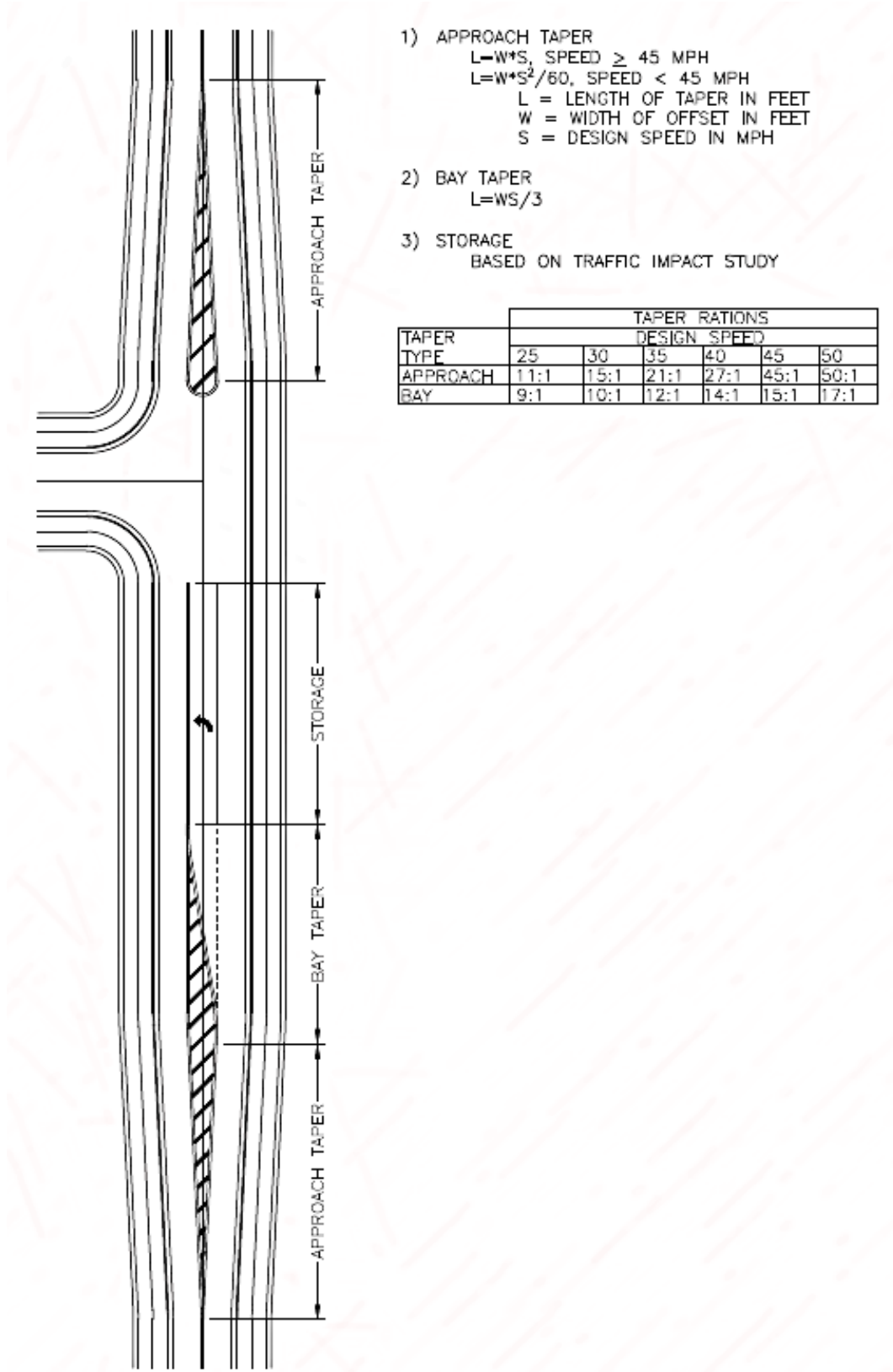

Left Turn Lane

Figure 2.3

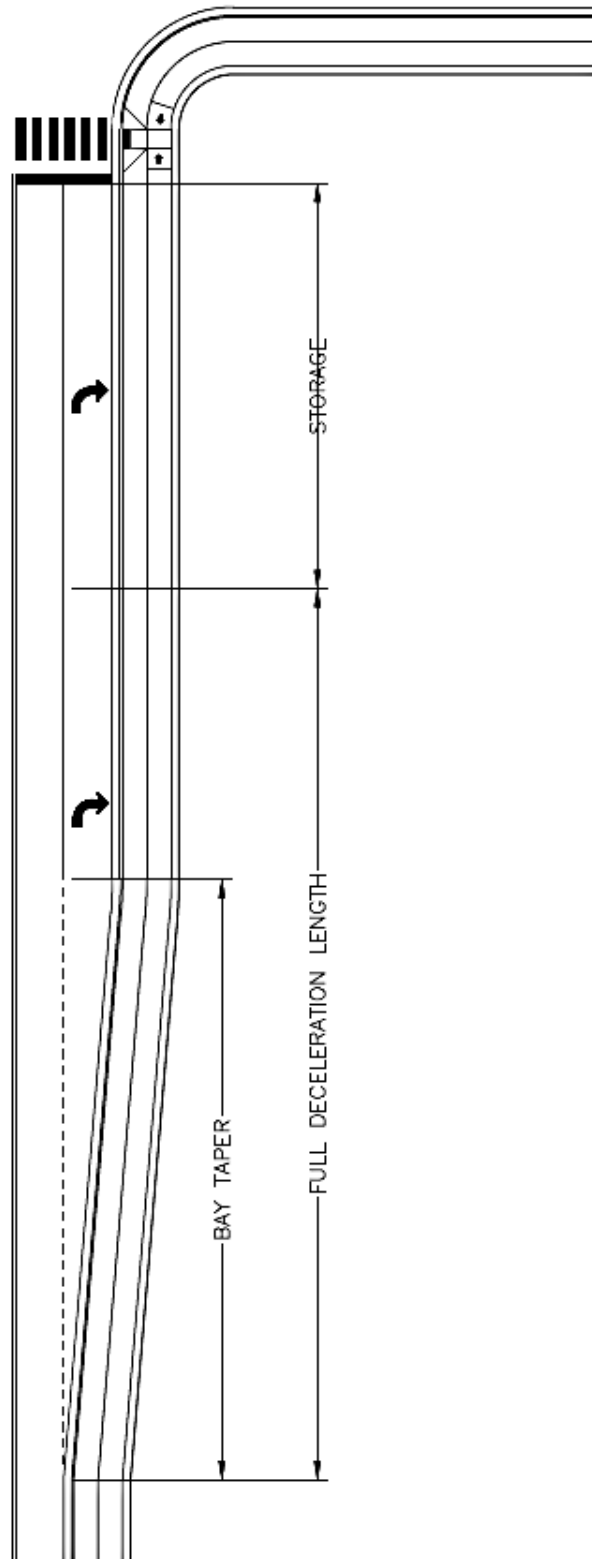

Right Turn Lane  
Figure 2.4

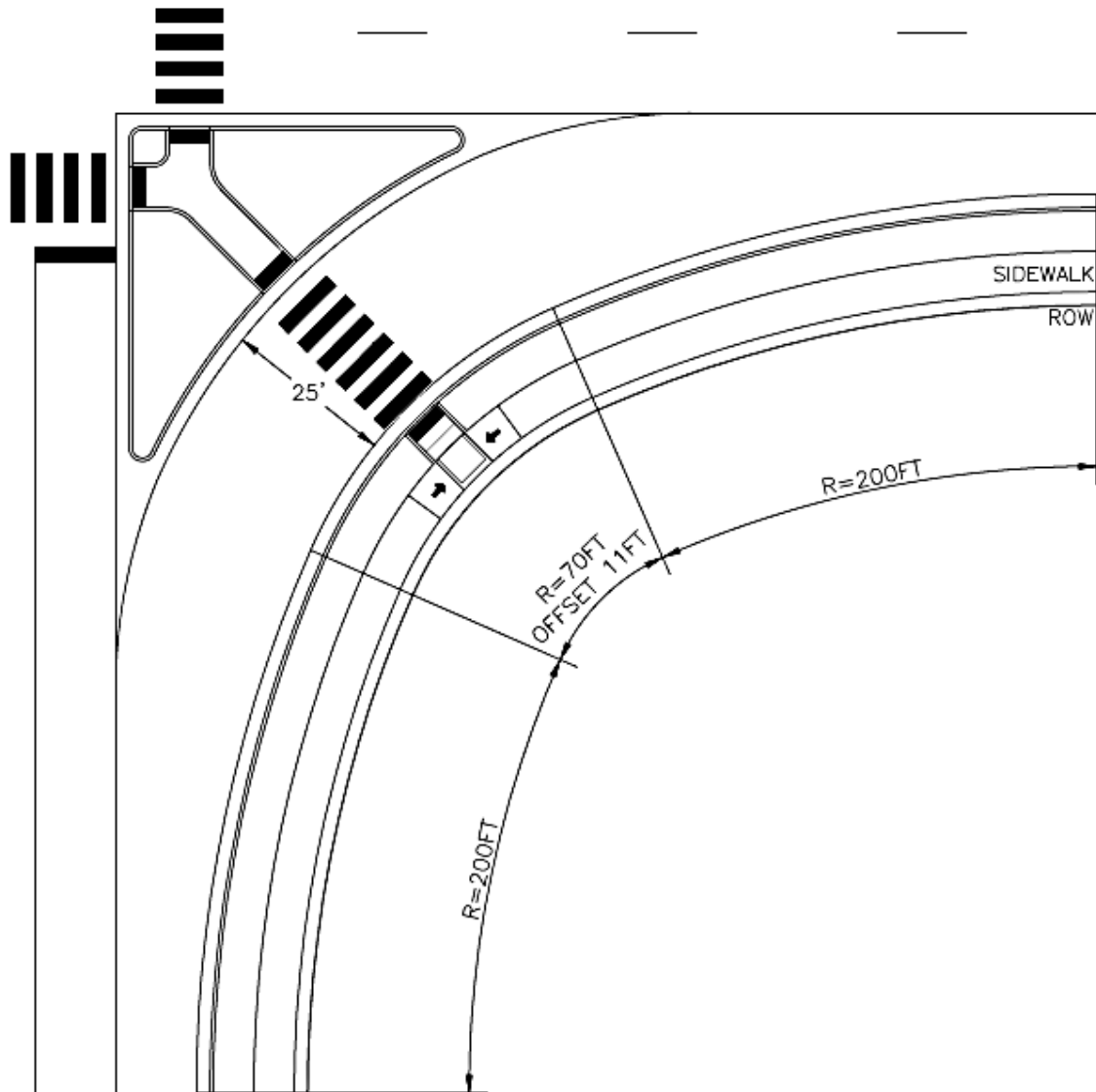

- 1) SEE GREEN BOOK AND TDOT STANDARDS FOR DESIGN OF CORNER ISLANDS.
- 2) REFER TO MUTCD AND TDOT STANDARDS FOR PAVEMENT MARKINGS.
- 3) TURNING RADIUS BASED ON DESIGN VEHICLE AND ROADWAY CLASSIFICATION.

Pedestrian Refuge Island Design with Continuous Right Turn  
and Three-Centered Curve

**Figure 2.5**

11. Curb Returns

- A. Radii of Curb Returns: The corner radii at street intersections shall meet the following minimum requirements of [Table 2.9](#) unless otherwise approved or required by the City Engineer. For curb returns on a State Highway, IDOT’s curb radii requirements shall supersede these requirements. At street intersections in residential areas, the minimum curb return shall be twenty-five (25) feet. In industrial and commercial areas, and when a residential street intersects with a non-residential street, the minimum curb return radius shall be thirty (30) feet. Should the expected right-turning truck volumes exceed ten (10) vehicles per hour in the design hour, then the designer shall use larger radii or 3-centered compound curves to provide for the turning movements of the larger vehicles. Where the angle of the street intersection is less than ninety (90) degrees, the City Engineer may require greater radii. See [Table 2.5](#) for general requirements regarding vehicle turning needs at intersections.

Corner Radius	Operational Characteristics
≤ 9	Not appropriate for passenger cars.
25-30	Low speed turn for passenger car; crawl-speed for single unit trucks with minor lane encroachment.
40	Moderate speed turn for passenger cars. Low speed turn for single unit trucks with minor lane encroachment.
50	Moderate-speed turns for all vehicles up to WB-50.

Curb Returns

**Table 2.9**

- B. Curb Return Grades: The desirable grade for gutter flow-lines around the curb return shall be a minimum of one (1) percent. The minimum allowable grade for gutter flow-lines around curb returns shall be a minimum of one-half (0.5) percent.

12. Traffic Islands

- A. Corner Islands Separating Right Turns: Standard corner islands shall be used in four (4) or six (6) lane Arterial/Arterial intersections to channelize traffic where required to provide pedestrian refuge or where required by the City Engineer. The corner islands shall be designed as raised islands in accordance with [Figure 2.5](#) and “Green Book” Standards, for a right turn lane continuing to an exclusive lane or for a right turn lane stop or yield condition, respectively. The striping shall be in accordance with the requirements of the [Section 7, Traffic Signs and Markings](#).



## Section 2 Design Requirements for Transportation Facilities

### B. Median Islands Separating Opposing Traffic: Median Islands are required at all Arterial/Arterial Intersections.

If raised medians are not required by these Specifications, the median islands may be raised or painted. The length of the island shall include the appropriate approach taper, bay taper and length of lane required by the Specifications, or supported by another approved resource standard. The design shall be as follows:



Typical Raised Median

- (1) No Obstruction. Medians must not obstruct the minimum left turn radius for the design vehicle(s).
- (2) Drainage. Landscaped medians shall include drainage facilities to handle sprinkler run-off and nuisance flows. When low maintenance landscaping is used in conjunction with trickle irrigation, drainage requirements may be waived and outfall curb and gutter shall be used.
- (3) Median Islands Required. Median islands are standard on all new 6-lane and 4-lane Arterial streets. These islands shall be designed to provide pedestrian refuge.

### C. Median Islands on Minor Arterials, Collectors, or Local Streets: Raised medians may be placed in Minor Arterial, Collector, and all Local streets. If medians are included, they shall be placed in the public right-of-way, and they must meet the following standards for design:

- (1) No Obstruction. The medians may not obstruct the design vehicle turns.
- (2) Visibility. The medians must be placed such that the required visibility in the intersection is not obstructed.
- (3) Undiminished Use. Medians must be placed so they do not diminish the intersection use except where designing a right-in/right-out intersection.
- (4) Alignment. Lanes on one side of the intersection must align with the correct lanes on the opposite side of the intersection.
- (5) Median Maintenance. Most medians will be maintained by parties other than the City. The maintenance responsibility must be defined on the Final Plat or Development Agreement. The City will maintain selected medians, primarily along State highways based on agreements with IDOT.
- (6) Public Use. The City may use these islands for street signing and may choose

## Section 2 Design Requirements for Transportation Facilities

to remove the medians if it is deemed necessary by the City Engineer.

- (7) Additional Right-of-way. The Developer shall dedicate all additional right-of-way necessary to include these medians.
- (8) Compliance with these Standards. The median design must comply with all applicable median criteria in these Standards and the streetscape standards of the City.

- D. Turn Prohibition Islands: An intersection may be designed with islands to prohibit left and right turn movements into or out of the intersection. Typically, these islands should not be used unless there is also a street median present to ensure that improper movements are not made.



Turn Prohibition Island

- E. Splitter Islands on Roundabouts: In modern roundabout designs, raised splitter islands shall be designed in accordance with the Federal Highway Administration "*Roundabouts: An Informational Guide*" to direct traffic and provide pedestrian refuge.

### 13. Right-of-Way

All intersection rights-of-way and utility easements shall be dedicated to provide adequate right-of-way to include sidewalks, access ramps, and utilities. Additional right-of-way may be required at intersections to provide space for additional left or right turn lanes without reducing the widths of standard required facilities. Where standard intersections are used, additional right-of-way may be required to accommodate the potential installation of a roundabout in the future.

### 14. Channelization

Channelization refers to physical or visual guides used to separate vehicles, bicycles

## Section 2 Design Requirements for Transportation Facilities

and pedestrians into particular lanes.

### A. Intent of Channelization:

- (1) Prohibit undesirable or wrong way movements.
- (2) Define desirable vehicular paths.
- (3) Encourage safe vehicle speeds.
- (4) Separate points of conflict wherever possible.
- (5) Cause traffic streams to cross at right angles and merge at flat angles.
- (6) Facilitate high-priority traffic movements.
- (7) Facilitate traffic control scheme.
- (8) Remove decelerating, stopped, or slow vehicles from high-speed through-traffic streams.
- (9) Provide safe crossings for pedestrians/bicycles.
- (10) Provide safe refuge for pedestrians.



Channelization at Intersection

### B. Specific Channelization Requirements: Channelization shall be required at locations where it is necessary for safety or to protect the operation of the major street. Examples include:

- (1) Providing raised medians in all Arterials where left turns are prohibited.
- (2) Prohibiting undesirable turning movements such as right and left turns, in and/or out.
- (3) Providing exclusive turning lanes, with appropriate striping.
- (4) Providing travel lanes, with widths as specified in the standard street cross sections.
- (5) Raised islands must be large enough to be visible to vehicle drivers. Therefore, no single island, including pedestrian paths and/or pedestrian refuge, shall be smaller than 100 square feet.

## 15. Street Narrowing

Minor Collector or Local Streets may be narrowed at intersections to provide more visibility for pedestrians. This shortens the distance necessary for pedestrians to cross the street. The narrowing shall not encroach into bike lanes or travel lanes. Narrowing may not be used on Major Collectors without any parking lanes, on any Arterials, or where the standard width is necessary. When narrowing is proposed, turning paths shall be evaluated to ensure that anticipated service vehicles (fire,

## Section 2 Design Requirements for Transportation Facilities

sanitation, school buses) can be accommodated with the proposed design.

### 16. Roundabouts

Roundabouts are considered a form of traffic control. Roundabouts shall be considered as two types:

- A. **Modern Roundabouts:** Modern Roundabouts shall be specially designed to the specific need on high traffic volume streets and used to improve traffic flow. Roundabouts shall be designed based on the FHWA's, "*Roundabouts: An Informational Guide*", "*IDOT Local Roads and Streets Manual*" for typical layout and comply with all "*PROWAG*" requirements.
- B. **Mini Roundabouts:** Mini Roundabouts may be allowed in a neighborhood setting for traffic calming. Mini roundabouts may be used on Local Streets. The design shall be performed in accordance with the FHWA's "*Roundabouts: An Informaitonal Guide*", or other design criteria approved by the City Engineer.

## **2.030.14 Sidewalks, Curbs & Gutters, Shoulders and Ditches**

### 1. Sidewalks

- A. **Typical Cross-Sections:** Street cross sections that include sidewalks shall be as specified in this Section.
- B. **Clear Zone:** Sidewalks shall be designed to provide a desirable lateral clear zone of six (6) feet for conventional areas. Vertical clearance shall be seven (7) feet or higher.
- C. **Other Sidewalk Requirements:** Refer to [Section 2.040, Pedestrian Facilities](#), and Title 17 of the Collinsville Municipal Code for other related sidewalk requirements and guidance.
- D. **Setback:** Sidewalks shall be set back a minimum of six (6) feet behind the street curb along lots within conventional areas. The intervening space between the back of the curb and the edge of the sidewalk is intended for the placement of street trees and other roadside features.
- E. **Minimum Width:** Sidewalks and trails running along streets shall meet the minimum widths as specified in [Table 2.3](#).
- F. **Ramps:** Ramps meeting requirements of the Americans with Disabilities Act (ADA) shall be installed at the intersection of all sidewalks with public streets. Ramps shall be designed in accordance with *Accessibility Guidelines for*

## Section 2 Design Requirements for Transportation Facilities

### *Pedestrian Facilities in the Public Right-of-Way and Illinois Accessibility Code.*

#### G. Configuration

- (1) Sidewalks shall be constructed of concrete, textured pavers or a combination of these materials, and shall be raised above the adjacent street level. In special circumstances, brick sidewalks may be allowed by the City Engineer, provided that an agreement is executed requiring maintenance by others.
- (2) Pedestrian street crossings at intersections may be raised above the adjacent street level as a traffic-calming measure.
- (3) Sidewalks shall connect with existing or planned sidewalks at property boundaries.
- (4) Sidewalks shall connect building entries within and between developments.
- (5) Except where brick or pavers are used, all public sidewalks shall maintain a brushed concrete finish for safety.

H. Inlets: Drainage inlet accesses located in a sidewalk shall be integrated with sidewalks. The inlet access shall be flush with the sidewalk surface. No manholes, inlets, or other storm sewer facilities are allowed within curb ramps. Refer to [Section 8.030.04 of these Standards](#) for requirements for sizing of inlets. Inlets are not allowed in the curb return but shall be located at or behind the tangent points of the curb returns.

I. Payment In-Lieu of Sidewalks: See Title 17 of the Collinsville Municipal Code.

#### 2. Curb and Gutter

Type and Location: [Table 2.3](#) notes the type of curb and gutter to be used for the various street classifications and sections. The standard sections include a vertical face combined curb and a mountable curb section with integral gutter.

- A. Barrier Curb: Barrier curb sections without an integral gutter pan shall not be used unless approved by the City Engineer. Under no circumstances will they be used when water flows along the curb face.
- B. Ribbon Curbs: Ribbon curb, which is typically 8-inches wide at the top and is cast near the asphalt surface, may be used in locations such as alleys and adjacent to medians where surface water runoff is conveyed over the curb to detention areas.
- C. Standard Combined Curb with Gutters: The standard vertical face curb and gutter section shall be IDOT B-6.24. Local streets shall be allowed to use B-6.12



## Section 2 Design Requirements for Transportation Facilities

curb and gutter, according to IDOT Standard Specifications, as approved by the City Engineer.

- D. Spill Curbs: Where curb and gutter sections are used in superelevated streets and adjacent to medians, the gutter pan shall be sloped away from the median (“spill curb”) to allow sheet flow toward the drainage structures.
- E. Mountable Curbs: The standard mountable curb or “rollover” curb shall be IDOT M-6.24. Local streets shall be allowed to use M-6.12 curb and gutter, according to IDOT Standard Specifications, as approved by the City Engineer. Vane grating for mountable curbs requires a width transition of the gutter pan to match the traffic edge of the drain casting.



Vertical combined curb and gutter



Mountable curb with grate transition

- 3. Shoulders: All street constructed in the City shall be constructed with curb and gutter. However, in extenuating circumstances, shoulders may be allowed by the City Engineer on a case-by-case interim basis. Where authorized, they shall be provided in addition to the elements required for the typical cross sections contained in [Table 2.3](#).
- 4. Roadside Ditches
  - A. Location: Ditches are not normally allowed in the City unless otherwise approved by the City Engineer.
  - B. Ditch Profile: The profile grade of the ditch shall be maintained at a minimum slope of one (1.0) percent and a maximum slope of five (5.0) percent. The side slopes of the ditches outside of the right-of-way shall be minimum of 4:1 and meet any specific criteria of the drainage study. Flatter slopes may be considered when a paved invert is designed for the ditch bottom.
  - C. Ditch Slope: The slope and capacity of any roadside ditches shall be maintained in any areas that driveways cross the ditch. Each site is required to provide a concrete pipe, a minimum of twelve (12) inches in diameter, calculated to meet

## Section 2 Design Requirements for Transportation Facilities

capacity and strength requirements. The pipe shall be designed to have no less than twenty-four (24) inches of cover over the pipe. All portions of the driveway within the right-of-way shall be paved with concrete or asphalt.

- D. Ditch Maintenance: All driveway improvements within the right-of-way including piping, ditches, curb and gutter, and sidewalks are generally the responsibility of the City.

### 2.030.15

#### Medians

1. General Requirements

General criteria for medians are specified in [Table 2.3](#).

Also refer to Title 17 of the Collinsville Municipal Code.

In the City, medians are required on all Arterial and Major Collector Streets.

Raised medians are preferred, but depressed medians may be allowed on a case-by-case basis. Other

medians may be required by the City Engineer for specific circumstances to control traffic. Medians requested by developers may be approved as long as additional rights-of-way are dedicated and all maintenance shall be done by viable private parties. The minimum width of any raised median shall be four (4) feet wide, from face-of-curb to face-of-curb.



Typical Street Median

2. Turn Lane and Access

The design of medians shall include the evaluation for current and future turn lanes and accesses.

3. Design of Openings

Median openings shall be designed to accommodate the selected design vehicle for all movements. Raised islands and other geometric design features shall be installed at median openings when necessary to prohibit certain turning or cross movements in the intersection.

4. Spacing of Openings

The effectiveness of medians is diminished by frequent and/or poorly spaced median openings. Openings should therefore be carefully coordinated with public and private street access points. Median openings shall be located only at major

## Section 2 Design Requirements for Transportation Facilities

public or private access points, or at mid-block locations if needed to serve as U-turns. Optimum location of openings is best determined based on the findings of a Circulation Plan and Transportation Impact Analysis. Minimum spacing on major streets should be at least six-hundred (600) feet to accommodate back to back left turn lanes and weaving between openings.

### 5. Drainage

Landscaped medians shall be provided with drainage facilities to handle sprinkler runoff and nuisance flows. Sprinklers shall be designed to prevent spray onto pavement surface. A properly designed drain system shall be required.

### 6. Nose Design

Vehicle tracking templates shall be used to determine the optimum position and design of the median nose so that vehicles do not track onto the median and are coordinated with other movements within the intersection. The minimum radius for nose curbs shall be two (2) feet to flow-line.

### 7. Paving

When medians are not landscaped, they shall be paved with stamped, colored, or broom finished concrete in accordance with the City's streetscape standards.

### 8. Transitions

The ends of medians shall transition into turn lanes with a minimum radius of one-hundred (100) feet. Change in curb directions must be accomplished with the use of radii. Angle points shall not be allowed.

### 9. Objects

No permanent structures, including light poles, fire hydrants, trees, walls or other fixed objects in the median shall be placed within the clear zone as determined by the *Green Book*, or in any location that would obstruct sight distance except for structures as approved in these Standards. All objects placed within the clear zone shall be an approved IDOT/FHWA breakaway design.

## 2.030.16 On-Street Parking

### 1. General

This Section defines the parking criteria for on-street parking, including Uptown parking, parking on cul-de-sacs, and other special areas. Parking may be allowed on Local and Minor Collector streets at the discretion of the City Engineer. Parking shall not be allowed on Major Collector or Arterial streets, except in the Uptown area and along the St. Louis Road corridor.



## Section 2 Design Requirements for Transportation Facilities

2. Parallel Parking  
Parallel parking is permitted on certain streets as approved by the City Engineer.
3. No Parking Signs  
For all streets in which parking is limited or not allowed, “No Parking” street signs may be required as part of the street design.
4. Non-Parallel Parking  
Diagonal parking shall not be allowed on City public streets and shall not be allowed to utilize the public street for maneuvering. The City Engineer must specifically approve any on-street parking areas that are not designed as parallel parking. All areas approved for diagonal parking shall be designed at an angle of thirty, forty-five, or sixty degrees, as approved by the City Engineer.
5. Parking in Cul-de-Sacs  
See [Section 2.030.07.1, Cul-de-sacs](#).
6. On-Street Handicap Parking Requirements  
Where on-street parking is provided on the block perimeter and the parking is marked, a minimum number of parking spaces must be accessible and shall comply with the *Public Rights-of-Way Accessibility Guidelines* and *Illinois Accessibility Code*.
7. Inset Parking  
Parking inset from the curb line may be allowed by the City subject to the approval of the City Engineer. In these cases, additional right-of-way will likely be required to provide the roadside features listed in [Table 2.3](#).
8. Driveway Clearance  
A vehicular parking space within the street shall be designed with a minimum clearance of six (6) feet from the edge of a driveway.
9. Intersection Clearance  
A vehicular parking space within the street shall be designed with a minimum clearance of thirty (30) feet from the intersection flow-line. The designer shall establish the minimum clearance by reviewing sight distance requirement in the *Green Book*.
10. Mailboxes  
Special consideration shall be given to mailbox locations near on-street parking such that parked vehicles do not interfere with mail delivery.
11. Sidewalks and Trails Adjacent to On-Street Parking

## Section 2 Design Requirements for Transportation Facilities

Sidewalks, trails, and grass strips adjacent to on-street parking shall meet the minimum widths as specified in [Table 2.3](#). In the rare occurrences where space constraints necessitate the sidewalk or trail to be located immediately adjacent to the on-street parking, the grass strip may be removed subject to the approval of the City Engineer. In these cases, the sidewalk or trail width shall be as specified in [Table 2.3](#), but not less than 7 feet.

### 2.030.17 Bridges

#### 1. Lane and Sidewalk Widths

The width of street travel lanes and sidewalks across bridge structures shall be equal to the widths on the street approaching the structure. Sidewalk and lane widths shall not be reduced from approach dimensions when crossing a bridge structure. Grass strip width may be eliminated across the bridge.

#### 2. Rails

All bridge rail or safety barriers shall be concrete or metal beam guardrail constructed in accordance with approved IDOT Standard Specifications as approved by the City Engineer. Bridge rails shall incorporate aesthetic features such as form liners or stone veneers where approved by the City Engineer.

#### 3. Approach End Treatments

Approach end treatments for bridge rails shall be required at each end and shall be in accordance with IDOT Standard Specifications as approved by the City Engineer.

### 2.030.18 Clearance Requirements

#### 1. General

Streets shall be designed to minimize the potential for traffic accidents involving fixed objects beside the street travel way. The street designer shall consult the latest edition of the AASHTO *“Roadside Design Guide”* to design the safest possible roadside along City streets.

#### 2. Horizontal Clearance to Obstructions

The AASHTO *“Roadside Design Guide”* shall be consulted in the design process to identify the suggested clear zone dimensions and/or barrier for the street being designed. Regardless of this guidance, the desirable minimum lateral clearance from the face of curb to the nearest edge of an object is two (2) feet.

#### 3. Vertical Clearance

The minimum vertical clearance above a street is sixteen feet and six inches.

#### 4. Guardrails

The type and location of guardrails used in the City shall be approved by the City

## Section 2 Design Requirements for Transportation Facilities

Engineer on a case-by-case basis and comply with IDOT and FHWA standards. Wood guardrails are prohibited on public and private roadways within the City of Collinsville.

### 2.030.19 Barriers and Fencing

#### 1. Roadside Barriers

All safety barriers shall be IDOT/FHWA approved crash-tested barriers. Aesthetic treatments such as stone veneer, concrete with a form liner finish, or painted railings may be used with the approval of the City Engineer.



Bridge Rail Barrier

#### 2. Median Barriers

All median divider barriers shall be IDOT approved, crash tested barrier walls. Glare screens may be required for high volume streets as approved by the City Engineer.

#### 3. Fencing

No fencing shall be installed in the street right-of-way. Fencing installed behind the right-of-way shall not result in sight distance less than the recommended distances in this Manual.



## Section 2 Design Requirements for Transportation Facilities

### Access Fencing

#### 4. Maintaining Sight Distance

No fencing or barrier installed in or adjacent to the street right-of-way shall result in sight distance less than the recommended distances in this Manual.

#### **2.030.20 Provision for Utilities**

This Section sets forth the criteria and location requirements for all utilities located within the rights-of-way and/or public utility easements located adjacent to public rights-of-way, such as: water, sewer, storm sewer, subdrains, power (electric and natural gas), phone, cable television (CATV), fiberoptic cables, traffic signals and mailboxes. The City Engineer or appropriate agency, in consultation with the City Engineer, shall determine the final alignments of utilities. For new and widened streets, provisions shall be made to include conduit for future signal interconnects and all required pull boxes.

##### 1. Minimum Depth

Utilities shall be located at least thirty-six (36) inches below the finish grade elevation, unless specifically approved to be less by the City Engineer. The minimum depth of cover for storm sewer pipes may be reduced to twenty-four (24) inches to the top of pavement. Greater depth of cover may be specified by the City Engineer.

##### 2. Access Covers

A. Clearance: All manhole lids, utility access covers, and range box access covers shall be flush with the street finished surface. If located in concrete drives or sidewalks, all access covers shall be set flush with the surrounding concrete.

B. Wheel Path: Manholes or valves installed in the street travel way shall not be designed or constructed in the wheel path of the travel lane or at any location within a bike lane.

##### 3. Trees and Large Shrubs

A. Buried Utilities: Trees, berms or large shrubs shall not be placed directly over buried utilities in the public right-of-way or easement. Additional horizontal clearances from the trunk of any tree or shrub to any buried utility may be required by the City Engineer or respective agency, as required for access, repair and/or maintenance activities.

B. Overhead Utilities: Trees shall not be planted under overhead power lines when mature growth of the tree would encroach within the influence areas of the power lines.

## Section 2 Design Requirements for Transportation Facilities

4. Location Criteria
  - A. General: The utility locations discussed below are recommended for new development and preferred in the case of existing streets and established developments.
  - B. Water Mains: Water mains shall be located on the north and east side of streets. Water mains shall be separated by a minimum of ten (10) feet horizontally from sanitary sewer and storm sewer facilities. The vertical depth of the water lines shall meet the requirements of [Section 10 Water Distribution Facilities](#) of these standards.
  - C. Fire Hydrants: Fire hydrants shall be located two (2) feet minimum from curb and gutter flow-line or two (2) feet minimum from back edge of a sidewalk or ten (10) feet minimum from edge of pavement if no curb is present. In addition, the water line shall be located such that the valves will not be in the wheel path of the street lane.
  - D. Sanitary Sewers: Sanitary sewers shall be located on the centerline of the street pavement. If a median is present, the sanitary sewer line shall be located west or south of the median. The sanitary sewer shall be located such that the manhole locations are not within the wheel path of the street lane. The vertical depth of the sanitary sewer lines shall meet the requirements of [Section 9 Sanitary Sewer Facilities](#) of these standards.
  - E. Storm Sewers: The storm sewers shall be placed so the manhole locations are not within the wheel path of the street lane. The storm sewer lines shall meet the requirements of [Section 8 Storm Drainage Facilities](#) of these standards.
  - F. Natural Gas: Gas mains shall be located either within the right-of-way or in an adjacent public utility easement on the south and west sides of the street.
  - G. Power and Street Lighting: Generally, power and street lighting conduits shall be located on both sides of the street either within the right-of-way or in an adjacent public utility easement.
5. Other Systems
  - A. Cable TV/Telephone/Fiber Optic: Cable TV, telephone lines and fiber optic lines generally serve properties from the back. For mains along the street front the utility shall coordinate the location in the right-of-way or in an adjacent public utility easement with the City Engineer. All pedestal boxes, new and relocated, located in the right-of-way between the curb and the sidewalk shall be installed below ground.

## Section 2 Design Requirements for Transportation Facilities

- B. Mailboxes: Mailboxes shall be installed a minimum of one and one-half (1.5) feet from the face of the curb, or travel lane. Mailboxes shall not cause any sight obstruction for motorists exiting side streets or driveways. Mailbox supports shall not pose a fixed object hazard for vehicles and pedestrians.
- C. Poles:
- (1) Location: Poles, signs, and any other above ground streetscape (except regulatory signs) shall be located within five (5) feet of the right-of-way line or ten (10) feet from the travel lane (flow line), whichever is most restrictive.
  - (2) Clearance: Street light poles shall be placed no closer to the street than two (2) feet behind a vertical curb line and no closer than two (2) feet to any sidewalk.
  - (3) Pole Requirements: The City Engineer may require breakaway poles on public right-of-way where the speed limit is 40 MPH or higher.
  - (4) Engineer Approval: All poles within the public right-of-way must be approved by the City Engineer prior to the permit application for installation.
  - (5) Other Requirements: All signs and heights shall meet the requirements of [Section 7, Traffic Signs and Markings](#).
- D. Subdrains: Subdrain main lines may be permitted within the public right-of-way. The Developer shall be required to provide additional information and perform a soils investigation. In addition, subdrains shall be designed in accordance with the requirements of this manual. If the soils investigation shows that subdrains are required for private property foundations, these lines may be designed to be installed within the public right-of-way if all requirements of these Standards are met:
- (1) Private Property. Subdrains built within the right-of-way for private drainage shall be private improvements and shall have provisions for viable maintenance by the local homeowners association or other private entities. The City may require the private party to abandon or relocate such subdrains.
  - (2) Public Property. A subdrain is public if it is used to drain public improvements, such as the street/pavement section.
  - (3) Depth. Top of pipe shall be at least thirty-six (36) inches below pavement surface.
  - (4) Outlet. All subdrains shall outlet to a detention pond, inlet, or other approved location. Each outlet shall have a device to prohibit backflow into

## Section 2 Design Requirements for Transportation Facilities

outlet pipe.

- (5) Perforated subdrains for private improvements shall not be allowed within any public right-of-way or easement.
- (6) Professional Engineer. Subdrains must be designed by a Professional Engineer and are subject to approval of the City Engineer.

### 6. Utility Crossings with Bridge Structures

Conduit sleeves may be required within the bridge structures to provide for electrical, gas, telephone, and cable crossings. The City Engineer may require additional sleeves to be designed with the bridge structure for sewer, water, or other utilities.

### **2.030.21 Emergency Access Street Requirements**

Any emergency street access not on public right-of-way shall be provided in accordance with the Collinsville Municipal Code or in accordance with the requirements of the City Fire Chief.

#### 1. Grade

The grade of the fire lanes shall be a minimum of one-half (0.5) percent and a maximum of eight (8.0) percent.

#### 2. Cross Slope

The Cross Slope of the fire lanes shall be a minimum of one (1.0) percent and a maximum of four (4.0) percent.

#### 3. Lane Width

The lane width shall be a minimum of twenty (20) feet from edge of the street to edge of the street and shall be in an access easement. The access easement shall have a minimum width of twenty (20) feet. The lane widths may be required to be increased through horizontal curves to accommodate fire truck passage.

#### 4. Vertical Clearance

There shall be a minimum of thirteen and one-half (13.5) feet of vertical clearance over the entire fire lane.

#### 5. Barricade

The fire lane may contain an approved barricade, but it must be of a type approved by the City Fire Chief.

#### 6. Signs and Markings

The fire lane shall contain signs and markings as required by the City Fire Chief.

## Section 2 Design Requirements for Transportation Facilities

### 7. Street Surface

The surface of the street must be a paved surface complying with Local Street pavement thickness requirements, unless approved otherwise by the City Engineer.

### 8. Maintenance

All access streets shall be maintained and kept clear for emergency use at all times.

## 2.030.22

### Bus Stops

#### 1. General

The minimum design criteria for the location and construction of bus stops is as described below. The City Engineer may vary any of the following requirements as deemed appropriate for the site and its particular situation. The Designer shall propose, and the City Engineer will approve the exact location of the bus stop in a proposed development. All bus bay locations shall be coordinated with the City Engineer.

Bus stop locations may be required to be constructed with special pavement designs.

#### 2. Bus Lane Width

Bus lanes shall be at least ten (10) feet wide.

#### 3. Approach Leg (Near-side) Minimum Criteria

Bus stops on the approach leg of an intersection shall be at least fifty (50) feet long, plus sixty (60) to eighty (80) feet of transition distance kept clear approaching the stop.

#### 4. Departure Leg (Far-side) Minimum Criteria

Bus stops on the departure leg of an intersection shall be at least fifty (50) feet long, plus forty (40) to sixty (60) feet of transition distance.

#### 5. Mid-Block Stops

The entrance and exit for mid-block stops shall be designed for the posted speed limit in accordance with transition criteria approved by the City Engineer.

#### 6. Bus Bays

All bus pullouts and bays required by the City shall be designed and constructed in accordance with AASHTO guidelines.

#### 7. Bus Shelters

For access and design guidelines for bus shelters required by the City, refer to AASHTO guidelines and "PROWAG" standards.



8. Bus Pullout Lanes

Bus pullouts shall be constructed with no less than fifty (50) feet between an intersection curb return (point of curvature, P.C.) and the beginning of the lead-in taper.

**2.030.23 Access Management & Design**

1. General

Driveway and street access to the public street system shall be evaluated in the preparation of any Circulation Plans and Transportation Impact Analysis. The City Engineer may modify any of the requirements of the driveway location and design standards based on trip generation, topography, and/or the anticipated impacts on traffic safety and movement on the street. Notwithstanding any other provisions of these standards, an access, which demonstrates a potential threat or danger to the public and/or which could affect the safe and efficient flow of traffic, may be denied by the City Engineer, based on commonly accepted and applied traffic engineering principles.

2. Driveway Design Criteria

The Circulation Plan shall provide for compliance with the minimum standards noted below for access from one or more lots in traditional and conventional areas to a public street.

3. Number of Driveways Permitted

Access to streets shall be provided to lots either by means of shared access easements, private-drive easements, including frontage or rear access drives, or direct access.

A. From Arterial Streets

- (1) Shared-access or private-drive easements shall be used to serve multiple lots. However, when these are unavailable or deemed unnecessary by the City Engineer, then single lots fronting less than six-hundred (600) feet along an arterial street shall have no more than one driveway onto the arterial street.
- (2) Lots fronting between six-hundred (600) feet and twelve-hundred (1,200) feet along an arterial street may have a second driveway, provided that the City Engineer may approve additional driveways based on trip generation or topography.
- (3) Lots fronting in excess of twelve-hundred (1,200) feet along an arterial street may have additional driveways, provided that the City Engineer may approve additional driveways based on trip generation or topography, and it

## Section 2 Design Requirements for Transportation Facilities

is determined that the impact on traffic safety and movement on the street will be minimal.

- (4) Driveways serving the same lot shall be a minimum of two-hundred fifty (250) feet apart, measured from the nearest point of the radius return of the two driveways.
- (5) Access to a corner lot fronting two arterial streets shall be required to have access from the street with the lower average daily traffic volume. Access to a corner lot fronting an arterial street, and bordered by a collector or local street, shall be required to have access only from the collector or local street. A lot may be permitted to have an additional driveway from the abutting arterial street, provided that the City Engineer may approve additional driveways based on trip generation or topography, and it is determined that the impacts on traffic safety and movement on the street will be minimal. Approval may be conditioned upon other geometric improvements which will mitigate traffic impacts.

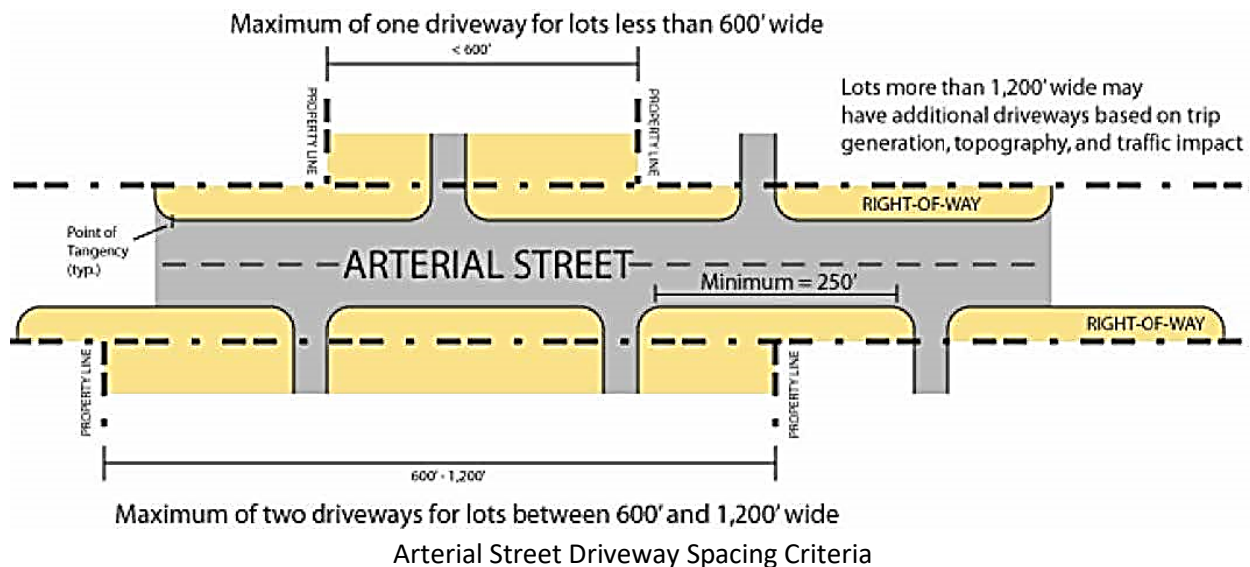

### B. From Collector Streets

- (1) Single lots fronting less than three-hundred (300) feet along a collector street shall have no more than one driveway onto the collector street.
- (2) For nonresidential uses, lots fronting more than three-hundred (300) feet along a collector street may have more than one driveway, provided that the City Engineer may approve additional driveways based on trip generation or topography, and it is determined that the impacts on traffic safety and movement on the street will be minimal.
- (3) Driveways shall be a minimum of one-hundred fifty (150) feet apart,

## Section 2 Design Requirements for Transportation Facilities

- measured from the nearest point of the radius return of the two driveways.
- (4) Access to a corner lot fronting two collector streets shall be required to have access from the street with the lower average daily traffic volume. Access to a corner lot fronting a collector street, and bordered by a local street, shall be required to have access from the local street. A lot may be permitted to have an additional driveway from the abutting collector street, provided that the City Engineer may approve the driveway based on trip generation or topography, and it is determined that the impact on traffic safety and movement on the street will be minimal.
  - (5) In general, no access shall be permitted to residential lots from collector streets. However, where no alternative access is available, residential lots with one-hundred twenty-five (125) feet of frontage or less shall be permitted to have one driveway. Residential lots fronting in excess of one-hundred twenty-five (125) feet along a collector street may have more than one driveway, provided that the City Engineer may approve an additional driveway only if it will have a minimal impact on traffic safety and movement on the street. Driveways shall be a minimum of fifty (50) feet apart, measured from the nearest point of the radius of return of the two driveways.

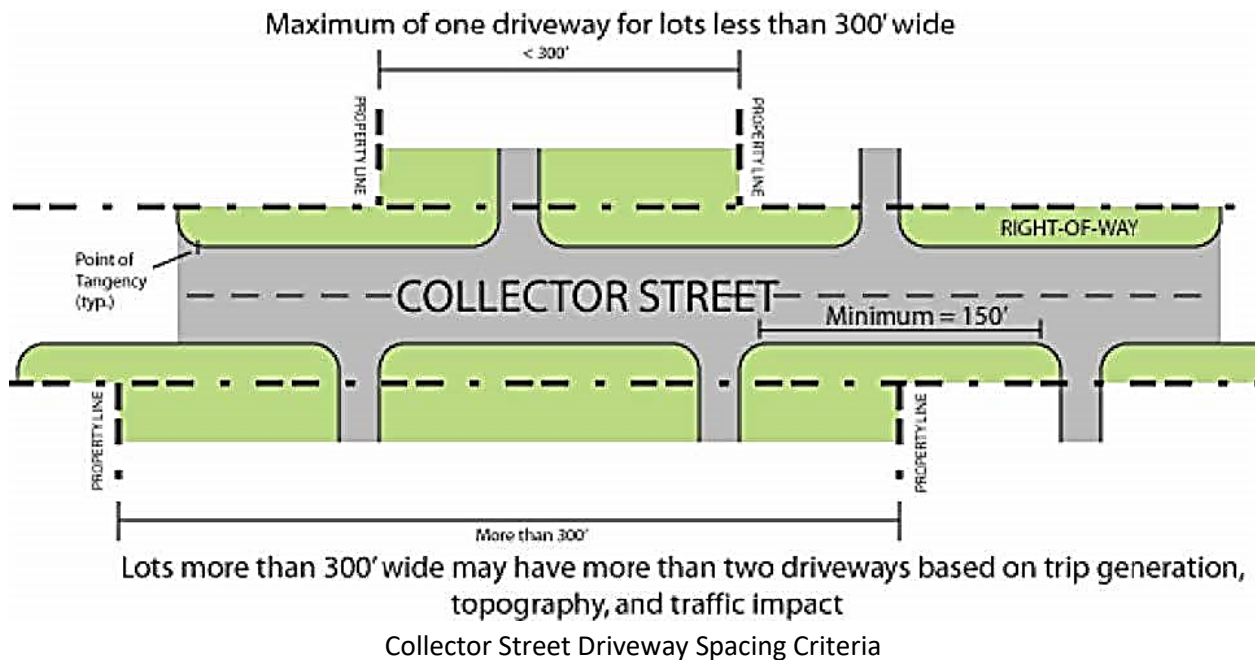

**Figure 2.7**

### C. From Local Streets

- (1) There shall be no more than one driveway for lots fronting less than one-hundred twenty-five (125) feet along a local street.

## Section 2 Design Requirements for Transportation Facilities

- (2) Lots fronting in excess of one-hundred twenty-five (125) feet along a local street may have more than one driveway, provided that, if approved by the Director of Community Development and the City Engineer. Driveway shall be a minimum of fifty (50) feet apart, measured from the nearest point of the radius return of the two driveways.

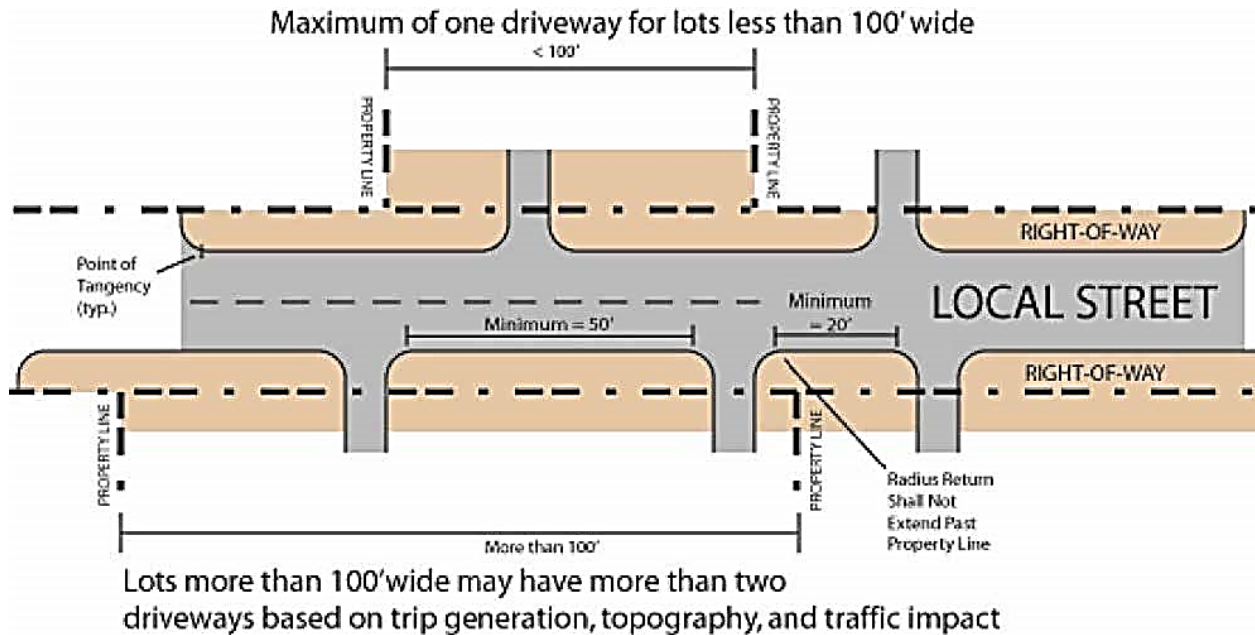

Local Street Driveway Spacing Criteria

Figure 2.8

4. Minimum Distance from Intersections
  - A. No low volume driveway to an arterial street shall be established within two-hundred fifty (250) feet of an intersecting street. See [Figure 2.9](#) for design criteria.
  - B. On collector streets, no low volume driveway shall be established within two-hundred thirty (230) feet of an intersecting street. See [Figure 2.10](#) for design criteria.
  - C. On local streets, no low volume driveway shall be established within one-hundred twenty-five (125) feet of an intersecting street. See [Figure 2.11](#) for design criteria.
  - D. All distance measurements shall be made from the nearest point of tangency of the curve of the intersecting street right-of-way to the nearest point of radius return of the driveway.

Section 2 Design Requirements for Transportation Facilities

- E. For residential uses, a corner lot abutting two local streets may have a driveway less than the above required distance from the intersecting street, if, in the opinion of the City Engineer, the driveway will not adversely affect traffic safety and movement on the streets.

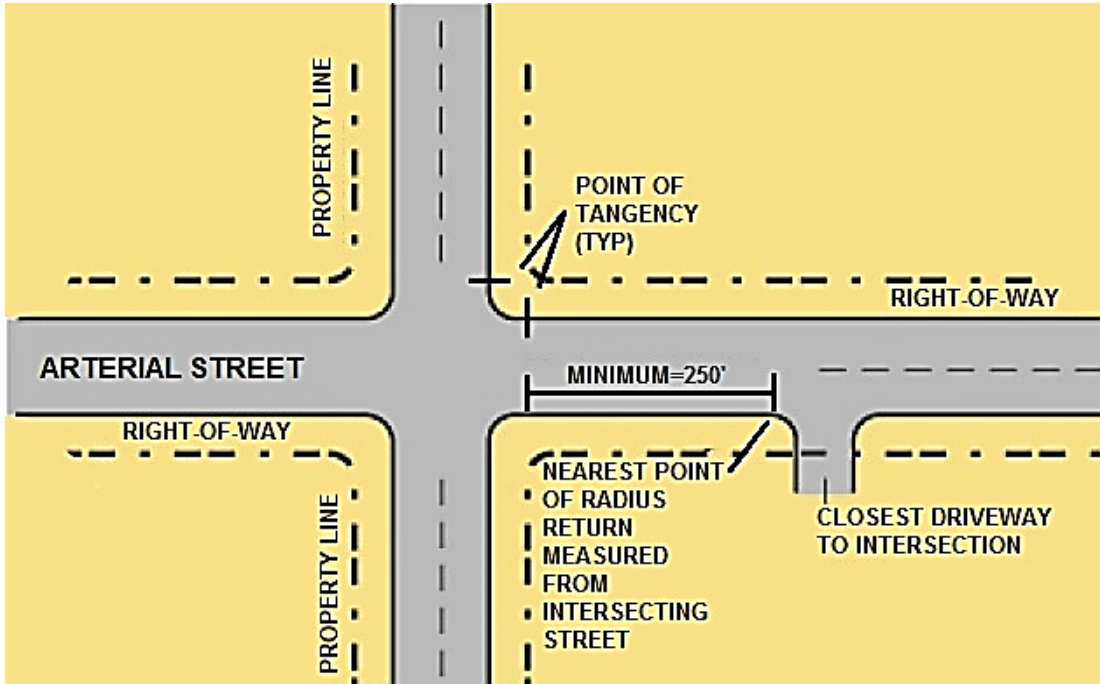

Arterial Street Driveway Intersection Clearance

Figure 2.9

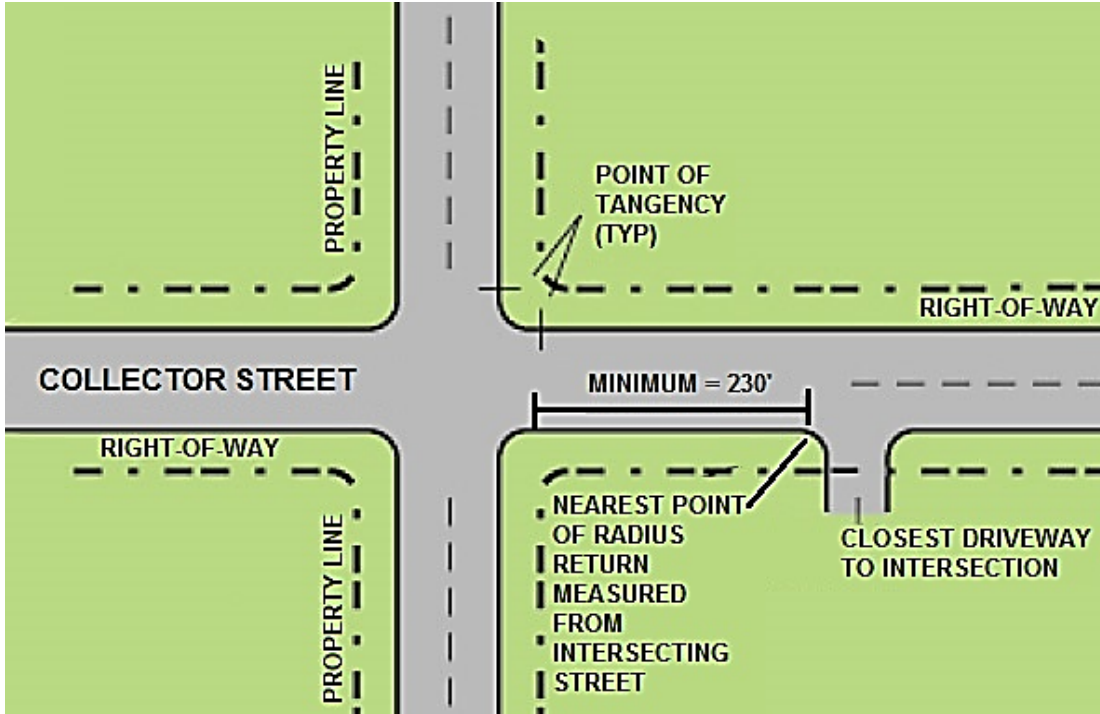

Collector Street Driveway Intersection Clearance

Figure 2.10

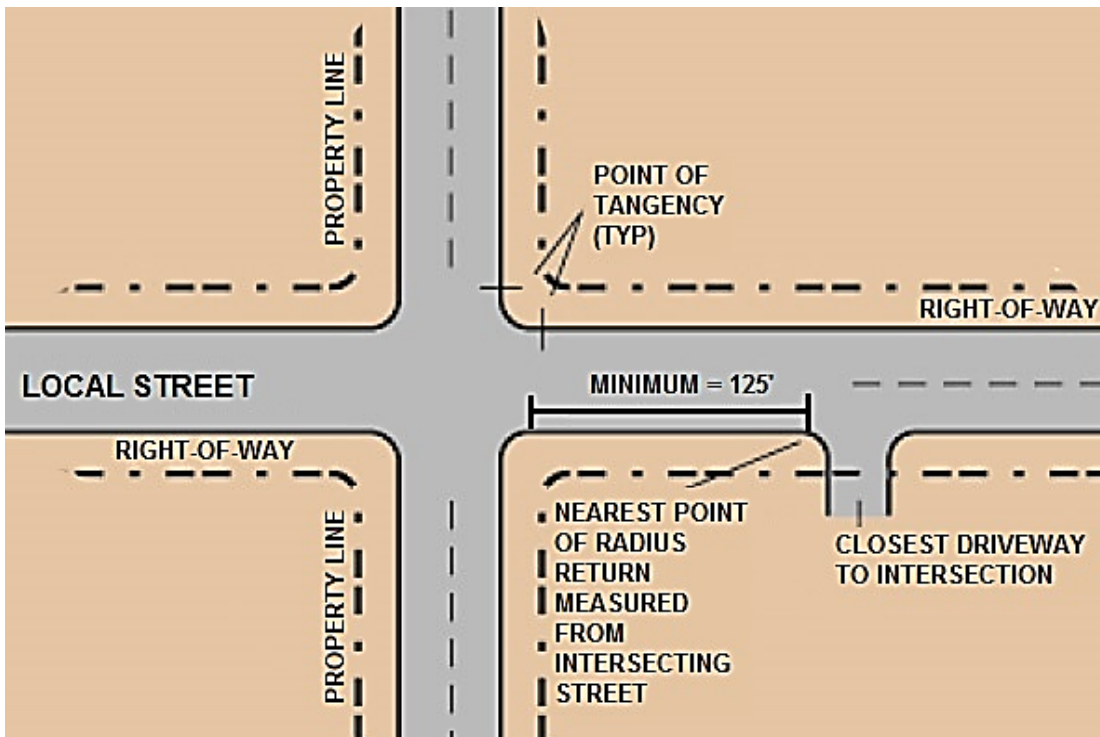

Local Street Driveway Intersection Clearance

Figure 2.11

## Section 2 Design Requirements for Transportation Facilities

5. Minimum Distance Between Driveways on Separate Lots
  - A. For nonresidential uses, no two driveways serving separate lots on an arterial street shall be less than two-hundred fifty (250) feet apart. See [Figure 2.9](#) for design criteria.
  - B. On collector streets, no two (2) driveways serving separate lots shall be less than one-hundred fifty feet apart. See [Figure 2.10](#) for design criteria.
  - C. On local streets, no two (2) driveways serving separate lots shall be less than twenty (20) feet apart. The distance between driveways shall be measured from the nearest point of the radius return of the two (2) driveways. See [Figure 2.11](#) for design criteria.
  - D. The minimum separation distance may be reduced, provided that, if approved by the Director of Community Development and the City Engineer, the following conditions exist, based on commonly accepted and applied traffic engineering principles: the use of shared-access or private street easements is not feasible or possible; exceptional topographic constraints or unusual site conditions exist at the driveway location (such as in-place utility or drainage features) which would make strict application of the standard exceptionally and/or practically difficult or unduly harsh; application of this Section would conflict with other sections of this Manual; and where the reduction would not constitute a threat or danger to the safe and efficient flow of traffic.
6. Minimum Distance from Property Line

No driveway, other than a shared-access driveway, shall extend beyond a straight line projection of any side or rear lot line; provided, however, that the provisions may be waived subject to approval by the City Engineer and Director of Community Development.
7. Deceleration Lanes

Approval of a nonresidential use driveway to an arterial or a collector street may be conditioned upon construction of a deceleration lane. The lanes shall be required in conjunction with each driveway to arterial or collector streets where a proposed land use will increase traffic volumes on the existing street to a total in excess of one-thousand (1,000) vehicle trips per day or one-hundred (100) peak-hour vehicle trips per day. The deceleration lane, a minimum of twelve (12) feet wide, measured from the face of the curb for curb sections without a monolithic gutter, the edge of the gutter for a monolithic curb and gutter section, or the edge of the shoulder for a non-curbed section to the center of the lane line, shall be constructed to City standards with the length measured from the centerline of the driveway according to AASHTO's "*Green Book*".



## Section 2 Design Requirements for Transportation Facilities

### 8. Acceleration Lanes

In instances of unusual topography or traffic safety considerations, the City Engineer may require the construction of an acceleration lane for nonresidential use. The length of taper and total length shall be determined based on AASHTO's "*Green Book*" and other commonly accepted and applied traffic engineering principles.

### 9. Left-Turn Storage Lane

- A. Approval of a non-residential use driveway to an arterial street or to a collector street which does not have an exclusive left-turn storage lane may be conditioned upon the construction of a left turn storage lane with appropriate median and/or pavement markings.
- B. The requirement and design of each storage lane, including the paved approach, bay, and departure tapers, shall be determined from the recommendations of the transportation impact analysis and approved by the City Engineer based on commonly accepted and applied traffic engineering principles. See [Figure 2.3](#) for design criteria.

### 10. Shared-Access Easements

- A. In the re-subdivision of property, the City Engineer may require private driveway easements or other conditions that require multiple lots or parcels to have shared vehicle access locations to arterial or collector streets such as through the use of rear-access or frontage drives where, in accordance with commonly accepted and applied traffic engineering principles, these may be necessary in order to provide for the safe and efficient flow of traffic. Rear-access or frontage drives shall be used only when they can be designed properly to provide safe and efficient access for properties.
- B. Where shared-access easements are required, the subdivision plat shall state that the transfer of lots shall be subject to the provision of such easements, which shall provide for a guaranteed, unrestricted, right of access to all other owners providing such easements and that the owners of lots subject to shared-access easements shall be required to execute an agreement specifying responsibility for construction and perpetual maintenance of the easements in accordance with the approved access plan. The agreement shall specify that the parties thereto shall hold the City harmless from liabilities resulting from unsafe conditions on shared-access easements.

Copies of the agreements from the current owners of lots through which shared-access easements are to run shall be filed with the City Engineer. Construction on shared-access easements shall not be commenced until all



## Section 2 Design Requirements for Transportation Facilities

agreements are filed. Copies of all subsequent amendments to the agreements shall also be filed with the City Engineer.

- C. In the event that the owners fail to maintain shared-access easements in a safe and stable driving condition, the Community Development Director, after appropriate notice, may have the unsafe or unstable conditions corrected and bill the owners for all reasonable costs. Should the owners fail to pay the City the amount of such charge within thirty (30) day from receipt of a certified invoice, then the costs shall be certified to the City Attorney, who shall process a lien on the properties upon which the expenditure was made.

### 11. Driveway Approach Length and Restrictions

Driveways for nonresidential, multi-family, and other similar uses must extend a minimum of thirty (30) feet into the property from the lot line abutting the street before the edge of the driveway may be intersected by a parking lot space, aisle, or drive. The minimum length of the driveway restriction may be extended, provided that it is determined by the City Engineer that anticipated traffic volumes and commonly accepted and applied traffic engineering principles justify the need for longer, controlled storage lanes. See [Figure 2.12](#) for design criteria.

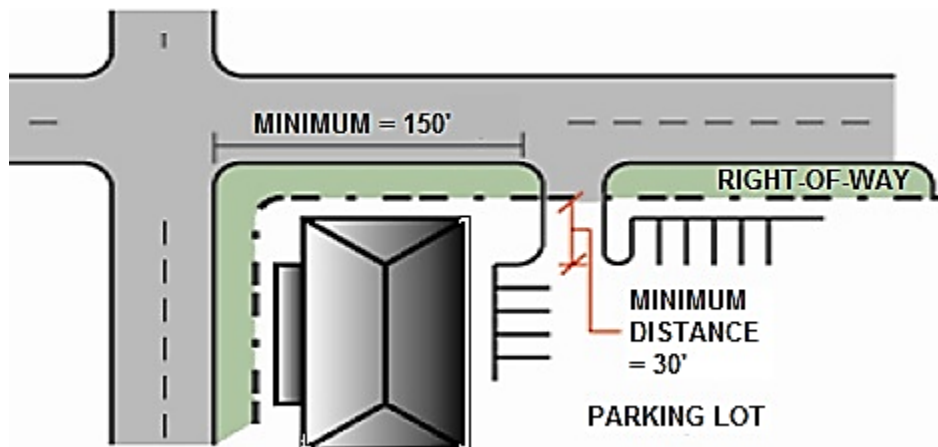

Driveway Approach Design Criteria

**Figure 2.12**

### 12. Driveway Width Requirements

- A. The width of driveways, measured at the nearest points of the radius returns, shall meet the requirements in the table below.
- B. Driveways to nonresidential uses may exceed the maximum width, provided that it is determined by the City Engineer that the need to provide safer turning movements and/or the number of trips generated for truck traffic to or from

Section 2 Design Requirements for Transportation Facilities

the property will justify the need for additional driveway lanes.

Use	Drive Width (feet)	
	Minimum	Maximum
Residential (to individual dwelling units)	12	24
Nonresidential - One Way Traffic	15	24
Nonresidential - Two Way Traffic <sup>1</sup>	24	35

NOTE: 1. Multilane driveways may be wider subject to approval of the City Engineer.

Driveway Width Requirements

**Table 2.10**

13. Median Driveways

Median driveways, in which ingress and egress lanes are separated by a minimum four (4) foot wide raised concrete curb median, may exceed the maximum two-way width, provided that the individual ingress or egress lane will not exceed the limits of one-way access width, and the median will not exceed fourteen (14) feet in width. These dimensions and lanes may be increased for higher-volume driveways if justified by a Transportation Impact Analysis. Additionally, monuments, walks, vegetation, or signing must not be located in the median in such a way as to interfere with driver vision and safety when entering or exiting the driveway.

14. Radius of Driveway Curve

- A. The radius of curve connecting the edge of the acceleration or deceleration lane or through-traffic lane and edge of driveway shall meet the requirements of [Table 2.11](#).
- B. The radius of the driveway curve to nonresidential uses may exceed the maximum length, provided that it is determined by the City Engineer that the need to provide safer turning movements and/or the number of trips generated to or from the property for truck traffic will justify the need for additional radius length.

Use	Radius of Curve (feet) <sup>1</sup>	
	Minimum	Maximum
Residential	5	15
Nonresidential:		
- Arterial	25	40
- Collector	25	30
- Local Street	10	25

NOTE: 1. A driveway flare may be used instead of a curve for residential uses.

Radius of Driveway Curve

**Table 2.11**

## Section 2 Design Requirements for Transportation Facilities

### 15. Pavement Markings and Signing

Driveways with more than one ingress egress lane shall have the pavement surface marked with center lines, lane lines, channelization lines, stop lines, and symbol arrows plus traffic control signing in accordance with the requirements of the "MUTCD". The pavement markings and signing shall be continually maintained by the property owner in good condition and visible to drivers at all times.

### 16. Materials

All driveway areas in the public right-of-way used for vehicular traffic shall be paved with Portland cement concrete (PCC) from the edge of street pavement to the edge of right-of-way or to the back of sidewalk, whichever is farthest from the curb. PCC may only be required to extend to the back of sidewalk if approved by the City Engineer. In the event a driveway serving a residential use is crossed by a concrete sidewalk, the portion of the driveway from the sidewalk to the flare of the driveway shall utilize the same material and finish as the sidewalk.

### 17. Additional Right-of-Way

The applicant shall provide or dedicate additional right-of-way and/or easement if it is determined by the City Engineer that the right-of-way and/or easement is necessary for street improvements, such as acceleration/deceleration lanes, as established on the approved access plan.

### 18. Offset from Opposite Streets

Intersections of streets with Major Arterial streets shall only align with streets intersecting on the opposite side of the Arterial street where a traffic signal or Roundabout will be permitted unless a raised median exists within the Arterial street that restricts the access at the intersections to right-in and right-out turns only. All other intersections must be offset by a minimum of one-hundred and twenty-five (125) feet or greater as required by the City Engineer.

### 19. Avoiding Conflicts in Center Left Turn Lane

When establishing the placement of offset accesses (either driveways or intersections), ensure that traffic making left-hand turns into the accesses do not conflict or compete for the simultaneous use of a center left turn lane.

### 20. Potential for Future Signalization

For any driveway access to a Major Arterial, an Access Management Plan and a signal progression plan may be required by the City Engineer. Generally, private direct access is discouraged onto a Major Arterial street to allow the Arterial to better meet its primary function. Public street access to a Major Arterial, where left turns are to be permitted, must meet the signal spacing criteria and the Access

## Section 2 Design Requirements for Transportation Facilities

Management Plan. Access points that do not meet these requirements shall normally be limited to right turns only, unless they meet the requirements above.

### 21. Public Street Intersection Spacing

Local streets should not typically intersect Arterials, but where they do they shall be spaced at a minimum of six-hundred sixty (660) feet. Full movement access to Major Arterials shall be limited to one-half mile intervals wherever possible, plus or minus approximately two-hundred (200) feet, in order to achieve good speed, capacity, and optimal signal progression. However, to provide flexibility for both existing and future conditions, an approved engineering analysis of signal progression shall be made to properly locate any proposed access that may require signalization.

### 22. Right Turns Only

Left turns may be prohibited, allowing right turns only. If left turns are restricted, raised medians will be required to prevent the left turn movements. Access points to arterials will normally be limited to right turns only (through signing and a raised median), unless:

- A. The access has the potential for signalization, in accordance with the general spacing requirements of this Section,
- B. Left turns would not create unreasonable congestion or safety problems and not appreciably lower the level of service, and
- C. Alternatives to the left turns would cause unacceptable traffic operation and safety problems to the general street system.

### 23. Entrance-Only and Exit-Only Approaches

Driveway approaches, where the driveway is to serve as either an entrance-only or exit-only drive, shall be appropriately signed by, and at the expense of, the property owner to guide motorists in proper driveway operation. The property owner shall provide whatever means are necessary to ensure that motorists will use the driveway in the intended manor.

### 24. Profile

The profile of a driveway approach and the grading of the adjacent area shall be such that when a vehicle is located on the driveway outside the travel portion of the street the driver can see a sufficient distance in both directions to enter the street without creating a hazardous traffic situation. The driveway profile grade within twenty (20) feet of the flow line shall not exceed eight (8) percent unless a variance is approved by the City Engineer. Driveways within the sidewalk and parkway area of the right-of-way shall slope toward the street. See [Figure 2.13](#) for allowable

## Section 2 Design Requirements for Transportation Facilities

grades and grade breaks for driveway approaches.

### 25. Adjustments for Existing Structures

Any adjustments made to utility poles, street light standards, fire hydrants, catch basins or inlets, traffic signs and signals, or other public improvements or installations required for the curb openings or driveways shall be accomplished without cost to the City.

### 26. Access to streets with No Curb and Gutter

Private drive access to Local, Collector, or Arterial streets that have no curb and/or gutter improvements shall be constructed to meet the following requirements:

- A. Surface Requirements: The driveway shall extend from right-of-way line to edge of existing driving surface and shall be constructed based on local street section or concrete driveway.
- B. Right-of-Way: New driveway accesses from private property to existing pavement shall be either hot mix asphalt (HMA) or PCC from right-of-way line to the edge of the traveled street. The width of the driveway within the right-of-way shall be twelve (12) to twenty-four (24) feet.
- C. Culvert: A culvert shall be installed at the established roadside ditch flow-line elevation beneath the private drive access. The culvert diameter shall be specified by an approved drainage report or in the absence of a report by the City. A culvert shall be installed in the flow-line of the ditch of a size necessary for the design storm flow (twelve (12) inch minimum diameter). The pipe shall have had flared end sections. The minimum cover over the culvert shall be twenty-four (24) inches. Additional cover may be required for heavy vehicles.
- D. Sketch Plan: A drawing of the proposed driveway installation showing all dimensions shall be submitted with the right-of-way or Access permit application.

### 27. Entrance Angle

In general, the entrance angle for all driveway approaches and intersections shall be as near ninety (90) degrees to the centerline of the street as possible. The minimum angle that will be permitted is ninety (90) degrees plus or minus ten (10) degrees for a minimum of twenty-five (25) feet measured perpendicular to the street and measuring from the curb or edge of pavement toward the private property served.

### 28. Access Approaches

Access approaches shall not be approved for parking or loading areas that require

## Section 2 Design Requirements for Transportation Facilities

backing maneuvers within the right-of-way except on Local Residential streets. All off-street parking areas on Collector and Arterial streets must include on-site maneuvering areas and aisles to permit user vehicles to enter and exit the site in forward drive.

### 29. Minimum Off-Street Parking Set Back Distance

Parking maneuvers within a parking lot shall not restrict entering vehicles from safely and efficiently entering the driveway from the public street. The minimum parking setback distance for non-residential driveways is 30 feet from the right-of-way line as described in [Section 2.030.23.11](#). The City Engineer may increase the distance based on a Transportation Impact Analysis.

### 30. Drainage

- A. Drainage at Curb Cuts: Where curb cuts are allowed, concentrated storm water runoff from property adjoining the right-of-way shall not be discharged across the sidewalk. These flows must be directed elsewhere or directed to a sidewalk chase where storm water may pass under a sidewalk section.
- B. Sheet Flow Drainage: Sheet flow drainage is allowed where it does not interfere with the pedestrian use of sidewalk.

Section 2 Design Requirements for Transportation Facilities

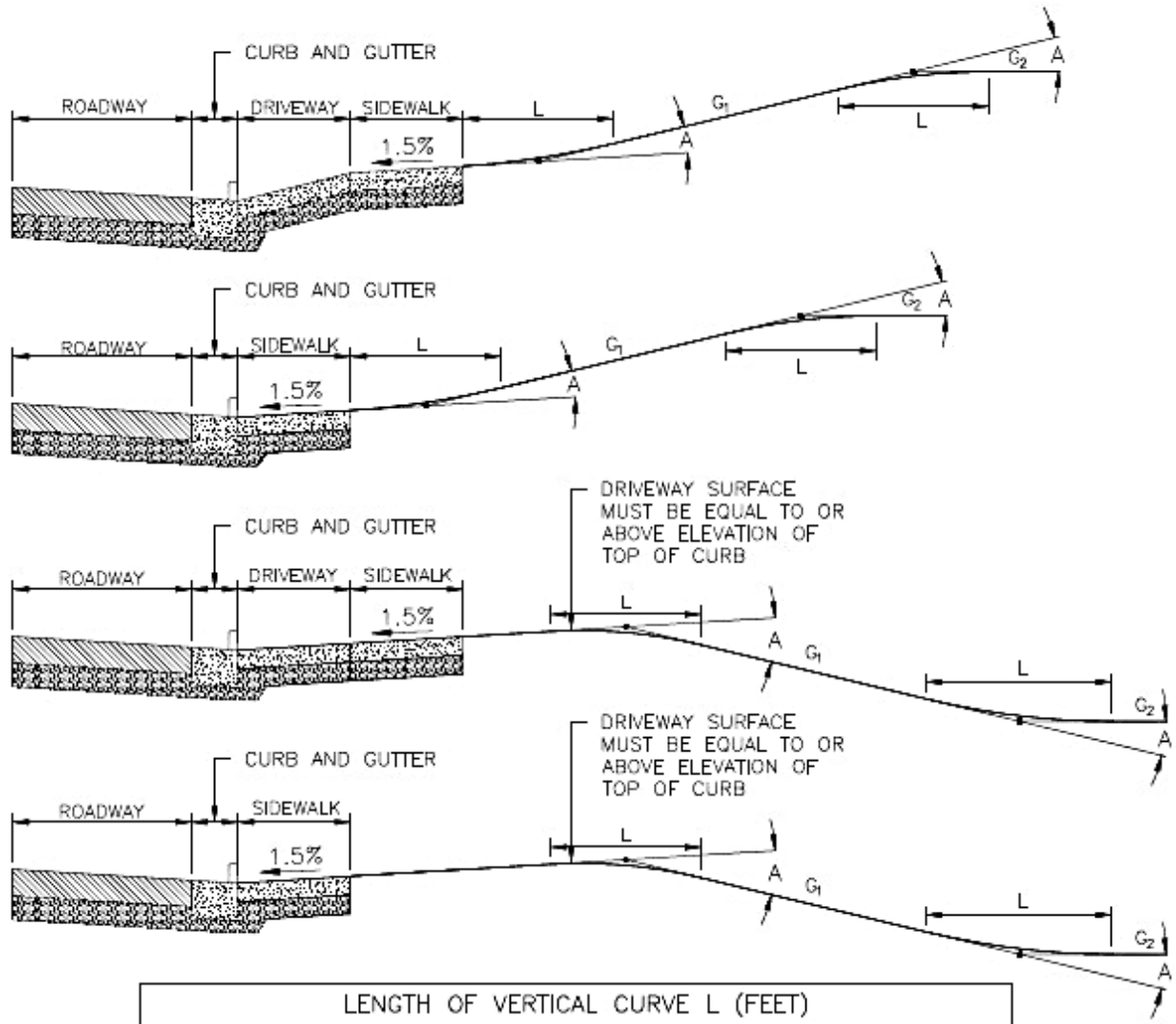

LENGTH OF VERTICAL CURVE L (FEET)				
CHANGE IN GRADE, A	CREST MINIMUM LENGTH		SAG MINIMUM LENGTH	
	DESIRABLE	MINIMUM	DESIRABLE	MINIMUM
4-5%	5 Ft	3 Ft	7 Ft	4 Ft
6-7%	6 Ft	4 Ft	8 Ft	5 Ft
8-10%	8 Ft	5 Ft	10 Ft	7 Ft

- 1) GRADES SHALL BE COMPATIBLE WITH THE SITE REQUIREMENTS FOR SIGHT DISTANCE AND DRAINAGE, TO PREVENT EXCESSIVE DRAINAGE RUNOFF FROM ENTERING THE ROADWAY OR ADJACENT PROPERTY.
- 2) MAX CHANGES IN DRIVEWAY GRADES WITH A VERTICAL CURVE (BETWEEN THE PAVEMENT CROSS SLOPE AND THE DRIVEWAY APRON SLOPE) IS 10% FOR PRIVATE RESIDENTIAL DRIVEWAYS AND 8 PERCENT FOR ALL OTHER DRIVEWAYS.
- 3) MAXIMUM DRIVEWAY GRADES SHOULD BE LIMITED TO 8 PERCENT UNLESS APPROVED BY THE CITY ENGINEER. WHERE POSSIBLE, THE DRIVEWAY GRADE SHOULD BE LIMITED TO 6 PERCENT OR LESS WITHIN THE ROADWAY RIGHT-OF-WAY
- 4) THE LENGTH OF THE VERTICAL CURVE BETWEEN THE PAVEMENT CROSS-SLOPE AND THE DRIVEWAY APRON IS A FUNCTION OF THE ALGEBRAIC DIFFERENCE IN THE GRADES. SEE TABLE ABOVE FOR DESIRABLE AND MINIMUM LENGTHS FOR THESE VERTICAL CURVES.

Driveway Profile Design Criteria

Figure 2.13

## Section 2 Design Requirements for Transportation Facilities

### 31. Change in Use

If the use of an existing access to right-of-way changes, or there is a change in the use of the property, the change in access use must be approved through the development review process, access management plan, or transportation impact analysis. Change in access or property use may include, but is not limited to, change in the amount or type of traffic (twenty (20) percent or twenty-five (25) vehicles per hour, whichever is less), structural modifications, remodeling, change in type of business, expansion of existing business, change in zoning, change in property division creating new parcels, etc.

### 32. Un-permitted Access

Any access, driveway, or curb-cut which is constructed within public right-of-way without a right-of-way or access permit issued by the City (or State if a State highway) shall be subject to removal. Failure to remove the un-permitted access may result in the removal of said access by the City. The cost for removal shall be charged to the property owner from which the access originates.

### 33. Abandoned Access

If a parcel of land with direct access has been in a state of non-use for more than one year, re-commencement of access use shall be considered a change in use. If the use of the access exceeds the design limitations of the access or does not conform to present code, a new approval may be required through the development plan review process, access management plan, or through a right-of-way permit.

### 34. Removal

Any curb opening or driveway that has been abandoned shall be removed and restored by the property owner except where such abandonment has been made at the request of, or for the convenience of, the City.

### 35. Access Permit Required/Appeals

- A. No curbs or rights-of-way shall be cut, paved, or otherwise altered for the purposes of obtaining access until a permit approving the access cut has been secured from the City and/or any other governmental agency owning or controlling street right-of-way.
- B. Whenever the City disapproves the location and design of a residential access, or when it is claimed that an equally good or more desirable access plan can be employed, or when it is claimed that the true intent and meaning of these standards have been misconstrued or wrongly interpreted, then the property owner, or his duly authorized agent, may appeal the decision to the City Engineer.



## 2.040 Pedestrian Facilities

All streets designed in Conventional areas of the City shall accommodate pedestrian travel as called for in this Section.

### 2.040.01 ADA Requirements

All pedestrian facilities provided within a City street right-of-way or easement shall be designed to accommodate movement by the disabled as required by the *Accessibility Guidelines for Pedestrian Facilities in the Public Right-of-Way* and the *Illinois Accessibility Code*.

### 2.040.02 Typical Sections

#### 1. Sidewalk Location

The minimum cross sections for sidewalks are provided in [Table 2.3](#). These cross-sections shall be used to construct sidewalks along both sides of a street. As shown, the cross sections are dependent upon the classification of the street on which they are located. For additional information regarding street classifications and street cross-sections, see [Section 2.020, Design Requirement for Transportation Facilities](#).

#### 2. Sidewalks on Streets with Ditches

On a street that has ditches instead of curb and gutter; the sidewalk shall be a minimum of five (5) feet wide and constructed of concrete. It shall also be located behind the ditch. Vertical objects shall be at least one (1) foot from the edge of sidewalk. A one (1) foot wide graded area that has a maximum slope of 6:1 shall be provided on each edge of sidewalk. The grass buffer strip, which contains the ditch and is located between the innermost graded area and the edge of street, shall be at least (12) twelve feet wide and shall be landscaped with grass. Drainage requirements may dictate an increased ditch section.

### 2.040.03 Managing Access for Pedestrian Safety

Unlimited access creates many points where conflicts may occur between pedestrians and vehicles entering or leaving the street. By restricting the number and size of driveways along a street, many of these potential conflicts can be avoided. When possible, multiple driveways shall be combined. If these driveways serve adjacent properties, cross-access drives between the properties shall be provided in order to eliminate the need for multiple driveways. Continuous access driveways shall be re-designed to create a limited number of entry/exit points. This design shall include grass strips between the street and the parking lot to prevent access at unwanted locations.

### 2.040.04 Intersections

All intersections shall be designed with the assumption that pedestrians will be present. Signalized intersections shall have crosswalks that are clearly marked. They shall also have ramps, landings, pedestrian push buttons, and other pedestrian features that are

## Section 2 Design Requirements for Transportation Facilities

accessible to everyone. The signing and pavement markings at intersections shall clearly indicate how all street users should operate.

### 2.040.05 Sidewalk Ramps

A sidewalk ramp shall be constructed for each crosswalk at each street corner.

### 2.040.06 Corners

An obstruction-free area shall be provided at street corners between the curbs and a continuation of the adjacent property lines. At a minimum, this distance shall be twenty feet. Only traffic control devices, street signs and posts, and pedestrian features shall be located in this area.

### 2.040.07 Crosswalks

#### 1. Crosswalk Locations

Crosswalks shall be provided on each leg of all intersections where significant pedestrian activity exists or is encouraged. They shall be clearly marked with two parallel lines or with a “ladder” pattern and they shall meet the ADA smoothness requirements.



Standard Crosswalk

#### 2. Mid-block Crosswalks

Mid-block crosswalks are generally discouraged in the City due to safety concerns associated with pedestrians crossing streets at unprotected locations. Before a mid-block is approved for installation by the City Engineer, a pedestrian crossing study shall be conducted to address the need for and expected use of the crossing. Should a crossing be recommended by the study and approved by the City, a traffic and safety analysis shall be completed to determine the optimum design elements of the crossing.

### 2.040.08 Detectable Warning Surfaces

The *Accessibility Guidelines for Pedestrian Facilities in the Public Right-of-Way* calls for detectable warnings for pedestrian street crossings, including curb ramps and blended transitions and certain median and refuge islands. These surfaces feature a distinctive pattern of raised domes to provide a tactile cue detectable by cane or underfoot at the boundary between pedestrian and vehicular routes. The City’s standard material for installing detectable warnings shall be Brick Red having Federal Color ID #20109, except in the Uptown area where the detectable warning shall be Clay Red having Federal Color ID #22144, cast in place and shall contrast visually with adjacent walking surfaces either light-on dark or dark-on light.

**2.040.09 Transit Stops**

Transit stops shall typically be located at the far side of an intersection. This design encourages pedestrians to cross behind the bus, improving their visibility to oncoming vehicles. A bus stop located on the near side of an intersection blocks the site lines between pedestrians and motorists. The preferred location for a transit stop waiting area is in the buffer strip between the sidewalk and the street. All transit stops shall comply with the *Accessibilities Guidelines for Pedestrian Facilities in the Public Right-of-Way*.

**2.040.10 Grade-Separated Pedestrian Crossings**

Grade-separated pedestrian crossings may be warranted across freeways, expressways or arterial streets where the volume of projected vehicular and pedestrian traffic justifies the expense of such a facility. Pedestrian overpasses and underpasses shall be designed based on *Accessibility Guidelines for Pedestrian Facilities in the Public Right-of-Way*. Where the grade separation directs the pedestrians under the street, the subway path shall be substantially illuminated and recessed in the structure.

## 2.050 Bicycle Facilities

All streets designed in the City shall accommodate bicycle travel as called for in this Section of these standards.

### 2.050.01 Types of Facilities

A bicycle lane is a travel lane that is between four (4) and six (6) feet wide designated for exclusive use or preferential use by bicyclists. The City standard shall be as shown in

[Table 2.3](#). Bicycle lanes are separated from conventional

travel lanes with a lane stripe and are identified by pavement markings and signing, in areas of high traffic lanes should be colored green according to NACTO's, "*Urban Bikeway Design Guide*". These facilities shall be one-way facilities, located on the right side of the street, that carry bicycle traffic in the same direction as the adjacent motor vehicle traffic. Another type of bicycle lane is a shoulder bikeway. A shoulder bikeway is a paved shoulder that is at least five (5) feet wide and that is separated from motor vehicle traffic by a lane stripe. It is also designated by signing. Unlike a bicycle lane, a shoulder bikeway is not designated exclusively for bicyclists. It may serve as a location to temporarily park a damaged vehicle, or it may serve other functions. Typically, shoulder bikeways are applied to rural streets that do not have curb and gutter.



Typical Bike Lane

### 2.050.02 Bicycle Shared Streets

A shared street is a street in which motorists and bicyclists share the same travel lanes. There are three types of shared streets:

- Wide Outside Lane (WOL)
  - Signed Shared Roadway (SSR)
  - Local Street
1. A WOL is a conventional travel lane, located on the right side of the street, that is typically fifteen (15) feet wide and that is shared by motorists and bicyclists. The extra width that is provided by a WOL allows motorists to comfortably pass bicyclists without changing lanes and without getting too close to the bicyclists. WOLs are identified by signing and can include pavement markings.
  2. An SSR is a street that is shared by motorists and bicyclists and is identified by signing. Unlike WOLs, SSRs do not provide additional street width for bicyclists. However, they should provide features that make them suitable for bicyclists. These

## Section 2 Design Requirements for Transportation Facilities

features include traffic control devices that are sensitive to bicyclists, bicycle-safe storm grates, and smooth pavement surfaces. They should also be routinely swept in order to prevent debris from accumulating on the street. Typically, SSRs are reserved for streets that have a high demand for bicycle traffic but cannot accommodate a bicycle lane or WOL due to physical constraints. SSRs should be considered as temporary bicycle facilities and should be replaced by bicycle lanes or WOLs as soon as feasible.

3. Local streets are typically low-speed, low-volume streets. Therefore, they do not usually require special treatment in order to accommodate bicyclists. However, signing may be used to identify a through-bicycle route that follows a local street.

### 2.050.03 Multi-Use Paths/Greenways

A multi-use path/greenway is a designated facility that is used for bicycling, walking, running, skating, and other forms of non-motorized travel. It is physically separated from motorized vehicular traffic by a barrier or open space and can be located within the street right-of-way or an independent right-of-way. Paths/greenways are typically twelve (12) feet wide. They are not part of the street network but may travel parallel to certain street segments. Also, these facilities may follow the course of natural boundaries, such as rivers and streams, or man-made boundaries, such as railroad lines and utility easements.

### 2.050.04 Bicycle Typical Sections

The recommended cross-sections for bicycle lanes, shared-use paths, and multi-use paths are presented in [Table 2.3](#) and IDOT's *"Local Roads and Streets Manual"*. In addition to the recommendations contained in these specifications, AASHTO's *"Guide for the Development of Bicycle Facilities"*, the *"MUTCD"*, and NACTO's, *"Urban Bikeway Design Guide"* shall be consulted in order to determine appropriate pavement markings, signing, etc. for new bicycle facilities.

### 2.050.05 Intersections

Intersections shall be designed so that a bicyclist's path of travel is direct, logical to both bicyclists and motorists, and is as similar to the path of motor vehicle travel as possible. Also, bike lanes shall extend to the stop line/crosswalk and shall not extend through the pedestrian crossing.

#### 1. T-Intersections

Left and right turn lanes for bicycles shall be provided unless severe physical constraints prevent the construction of two bicycle turn lanes. If physical constraints do exist, then the bicycle turn lanes can be omitted as long as the vehicular left turn lane is fourteen (14) feet wide. With either design, the bike lane across from the intersection shall be striped through the intersection. However, this bike lane shall not be striped through the crosswalk.

## Section 2 Design Requirements for Transportation Facilities

### 2. Intersections without Exclusive Right Turn Lanes

When a bike lane is present at an intersection that does not have an exclusive right turn lane, the solid bike lane stripe shall be replaced with a dashed line at least fifty (50) feet prior to the stop line/crosswalk.

### 3. Intersections with Exclusive Right Turn Lanes

At intersections with exclusive right turn lanes, the paths of motorists and cyclists should cross in advance of the intersection in order to reduce the number of conflicts that occur at the intersection. The pavement markings shall direct bicyclists to the left of the exclusive right turn lanes. The bike lane stripes shall be dashed across the area where motorists should cross into the right turn lane. The solid bike lane markings shall resume when the right turn lane achieves full width and shall continue to the stop line/crosswalk. Under severe physical constraints, the bike lane can be terminated if the outermost through lane is fourteen (14) feet wide.

## 2.060 Traffic Calming

### 2.060.01 General

This Section presents acceptable methods of neighborhood traffic calming that are determined by the City to be acceptable for use on existing local streets. This Section also provides for specific design criteria of a number of traffic calming methods.

#### 1. Intended Use

The necessity or desire for traffic safety and calming stems from the perception that local streets, particularly in residential areas, do not always function as intended. These streets shall be low traffic volume streets used for direct access to residences on the street. They are also intended as a multi-modal system that is shared by vehicular, bicycle, and pedestrian traffic equally, in a manner that minimally impacts residents in the area.

#### 2. For New Street Design

The devices presented in this Section are generally not intended for use on new streets. New street design is addressed earlier in this Section. New local streets are to be designed to minimize cut through traffic, high volumes, and high-speed operation and to maximize the efficiency of the street to provide vehicular access and bicycle and pedestrian traffic. Circulation plans prepared for new streets serving residential, nonresidential, and mixed-use development shall comply with the following standards.

- A. Minimal street widths, short block lengths, on-street parking, controlled intersections, roundabouts, and other traffic calming measures shall be used on all local and minor collector streets to the maximum extent practicable.
- B. In cases where residential development has been organized around a grid street network, measures to interrupt or ruminant long vistas exceeding twelve hundred (1,200) feet in length shall be employed to the maximum extent practicable. Such measures shall include, but shall not be limited to:
  - (1) Curvilinear street segments;
  - (2) Street jogs or off-sets designed to require vehicles to slow their travel speed;
  - (3) Street chicanes or neck downs;
  - (4) Terminated vistas;
  - (5) Mid-block traffic circles; and
  - (6) Stop signs at street intersections, where warranted.

### 2.060.02 Traffic Calming Techniques

#### 1. Approved Techniques

## Section 2 Design Requirements for Transportation Facilities

There are a variety of techniques that can be used to calm traffic on local, residential streets. Techniques that are specifically permitted, as well as techniques that are specifically prohibited, in the City are described below. Techniques that are specifically permitted are summarized in [Table 2.12](#), which also identifies the potential benefits and disadvantages of each.

Measure	Potential Benefits			Potential Disadvantages			Cost
	Speed Reduction	Volume Reduction	Conflict Reduction	Limits Local Access	Increases Emergency Response Time	Extent of Maintenance Required	
Chicane	■	■	■	□	■	■	\$\$-\$\$\$
Curb Extension	■	□	□	□	□	■	\$\$-\$\$
Education	■	□	■	□	□	□	\$
Enforcement	■	□	■	□	□	□	\$\$-\$\$
Lower Speed Limit	■	□	□	□	□	□	\$
Raised Median	■	□	■	■	□	■	\$\$-\$\$
Road Diet	■	□	■	□	□	□	\$\$-\$\$\$
Speed Table/Hump	■	■	■	□	■	■	\$\$-\$\$
Traffic Circle	■	■	■	□	■	■	\$\$-\$\$\$

■ Substantial Benefits/Disadvantages      ■ Minor Benefits/Disadvantages      □ No Benefits/Disadvantages  
 \$ Low Cost      \$\$ Moderate Cost      \$\$\$ High Cost

### Potential Impacts of Traffic Calming Techniques That May Be Used

**Table 2.12**

- A. Chicane: A chicane shifts motorists' path of travel by creating a horizontal diversion in the roadway. A chicane is usually formed by a series of curb extensions that are placed on alternating sides of the roadway. These curb extensions reduce the roadway width and force motorists to steer from one side of the roadway to the other in order to travel through the chicane. See [Figure 2.14](#) for a typical drawing of this technique.
- B. Curb Extensions: Curb extensions are formed by extending the curb on one or both sides of the roadway into the vehicular travel lanes to reduce the paved roadway width. The reduction in width creates "slow points" in traffic flow. Curb extensions are also commonly referred to as chokers, neck downs, traffic throats, bump outs, and pedestrian bulbs. Curb extensions reduce the width of the roadway at intersections and create shorter crossing distances for pedestrians. The reduction in lane width encourages motorists to slow down when driving through the intersection. See [Figure 2.15](#) and [Figure 2.16](#) for a typical drawing of this technique.



## Section 2 Design Requirements for Transportation Facilities

- C. Education: Education is a key component of all traffic calming projects in the City. Before implementing physical traffic calming measures, the City Engineer will work with neighborhoods and residents to educate them regarding safe, on-street, vehicular travel.
- D. Enforcement: Enforcement efforts will be combined with neighborhood education as a first step in all traffic calming projects in the City. The Police Department will work with the City Engineer to help resolve traffic problems, such as speeding. Enforcement efforts may involve the use of speed trailers and may include tickets for violators.
- E. Lower Speed Limits: Establishing lower speed limits may help to reduce speeding and cut-through traffic in residential neighborhoods. It may be desirable to lower the speed limit to 20 MPH on local, residential streets.
- F. Raised Median: A raised median is an elevated island that is constructed on the centerline of a two-way street to reduce the width of the adjacent travel lanes. Raised medians can be paved or landscaped. They create “slow points” in the roadway, can serve as pedestrian refuges for pedestrians crossing the street, and can be used in conjunction with other traffic calming measures. See [Figure 2.17](#) for a typical drawing of this technique.
- G. Travel Lane Reduction: Reducing the number of travel lanes, or the width of travel lanes, on a roadway can be an effective technique for calming traffic on that street. This process, called a “road diet”, can help reduce vehicular speeds, reduce the number of conflict points for right-of-way users, and can help make streets more bicycle and pedestrian friendly. Road diets can be accomplished by adding parking lanes, adding bike lanes, adding a median, or by reclaiming some of the roadway width, which can create room for sidewalks and street trees.
- H. Speed Table/Hump: A speed table/hump is a wide flat undulation that is placed on a street, typically across the width of the roadway, to reduce vehicular speeds. They have a height of three (3) to four (4) inches and a length of twelve (12) or twenty-two (22) feet. Speed humps shall be distinguished from speed bumps, which are much shorter (six to twelve inches long) and have been associated with maintenance, safety, and liability concerns. The speed table/hump that may be used in the City is twenty-two (22) feet long and three (3) inches high. See [Figure 2.18](#) for a typical drawing of this technique.
- I. Traffic Circles: A traffic circle is a raised, circular island that is typically placed in the center of a residential street intersection to allow traffic to flow through the

## Section 2 Design Requirements for Transportation Facilities

intersection without being controlled by a stop sign or a traffic signal. The design of a traffic circle requires motorists to travel through the intersection in a counterclockwise direction around the island, which reduces the number of conflict points and reduces vehicular speeds. A traffic circle creates a horizontal deflection in the roadway, which causes motorists to slow down as they travel through the intersection. See [Figure 2.19](#) for a typical drawing of this technique.

### 2. Prohibited Techniques

- A. Rumble Strips: Rumble strips are raised buttons, bars, or groves that are closely placed on a roadway at regular intervals. They cause both noise and vibration of vehicles as motorists drive over them. Typically, rumble strips are used to alert motorists of unusual conditions ahead. As motorists get used to the rumble strips, the strips become less effective over time. Rumble strips can result in increased noise levels for nearby residents. Also, rumble strips require a high amount of maintenance. For these reasons, rumble strips shall not be used as a traffic calming technique in the City.

Section 2 Design Requirements for Transportation Facilities

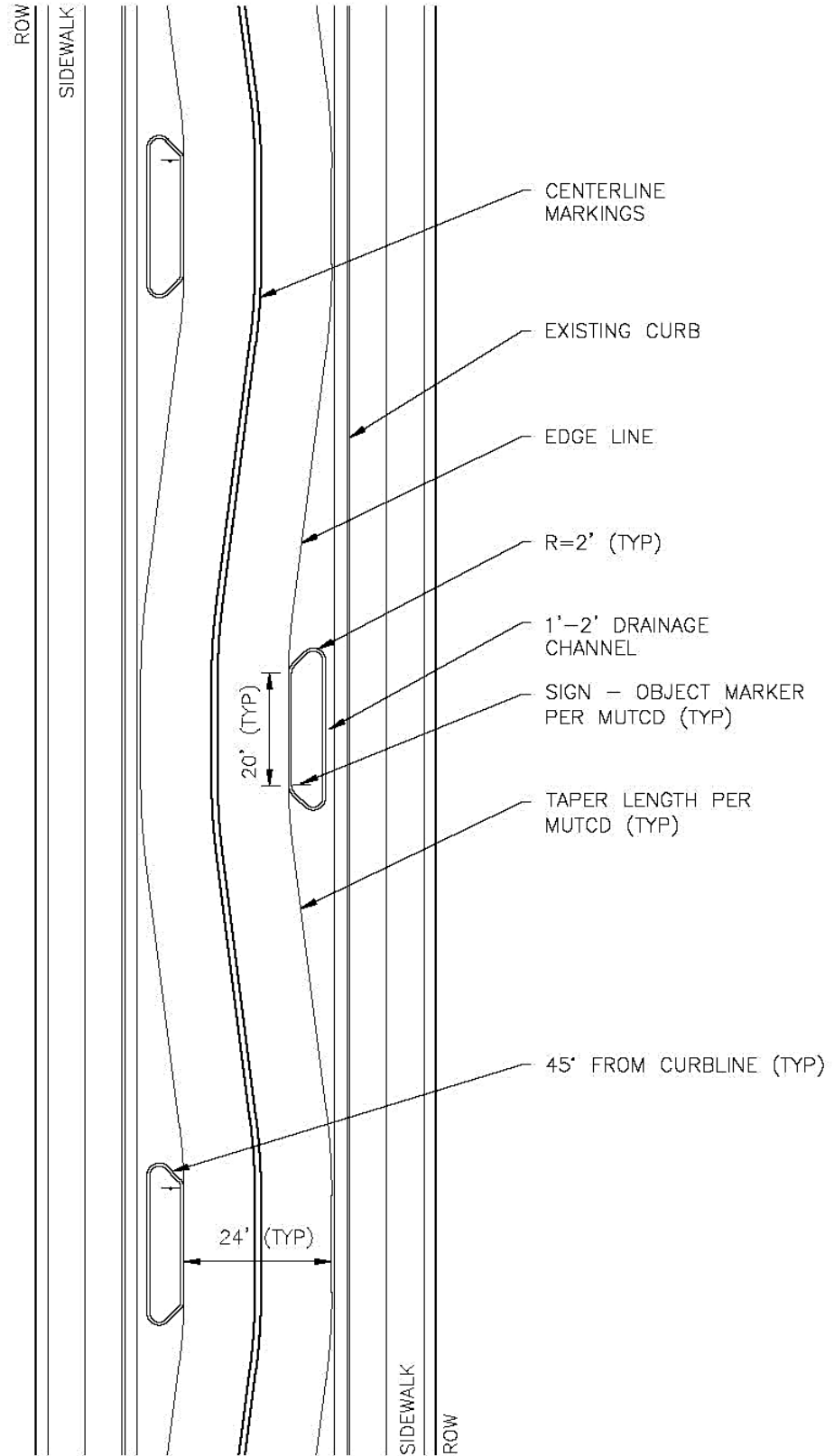

Chicane  
Figure 2.14

## Section 2 Design Requirements for Transportation Facilities

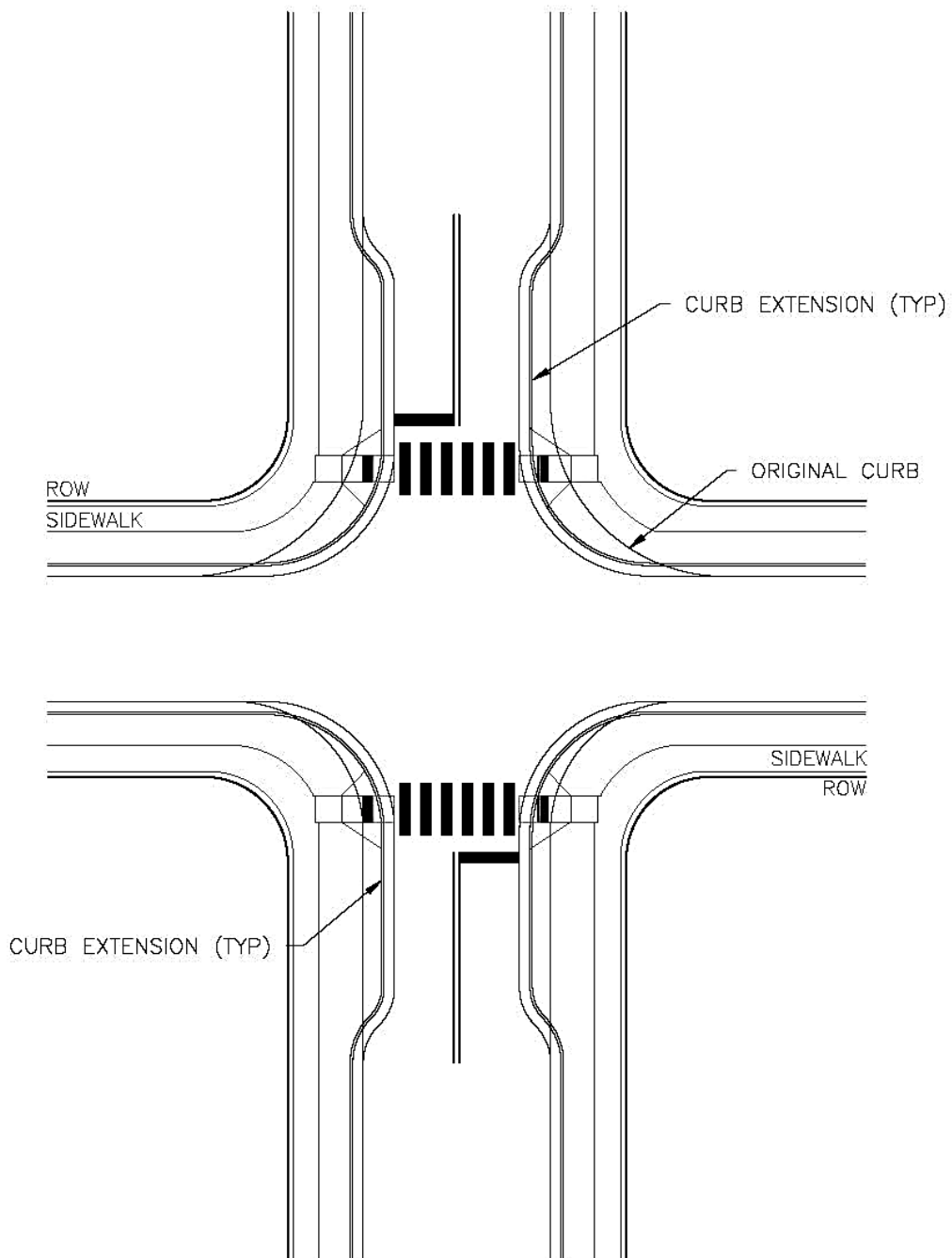

- 1) INTERSECTION RADII SHOULD ACCOMMODATE DESIGN VEHICLES APPLICABLE TO STREET.
- 2) MID-BLOCK CURB EXTENSIONS SHOULD BE COMBINED WITH CROSSWALKS WHERE POSSIBLE.
- 3) LENGTH OF CURB EXTENSIONS MUST RECOGNIZE SITE CONDITIONS, EX. DRIVEWAY LOCATIONS.

Curb Extension  
**Figure 2.15**

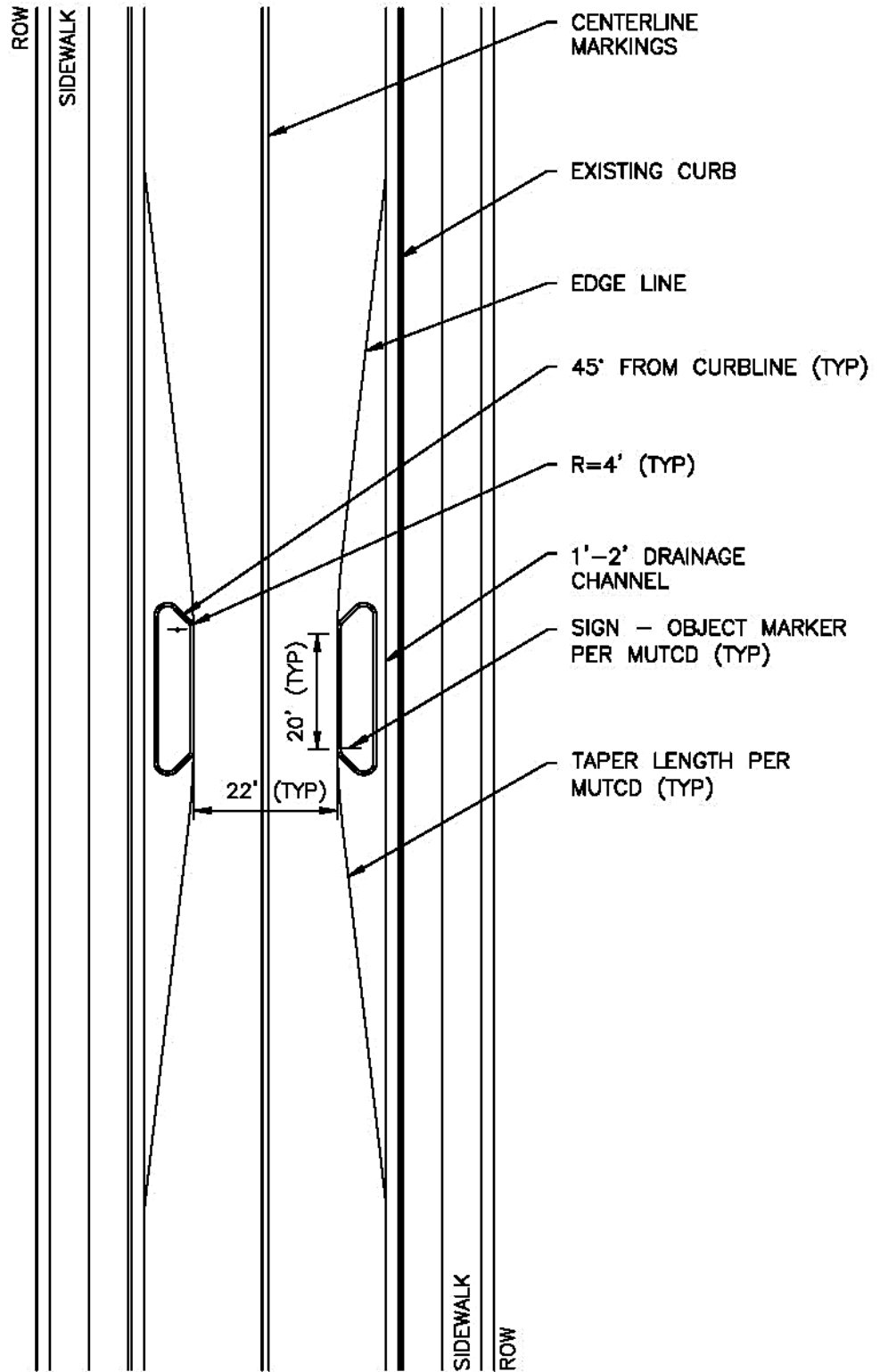

Curb Extension – Chokers

Figure 2.16

Section 2 Design Requirements for Transportation Facilities

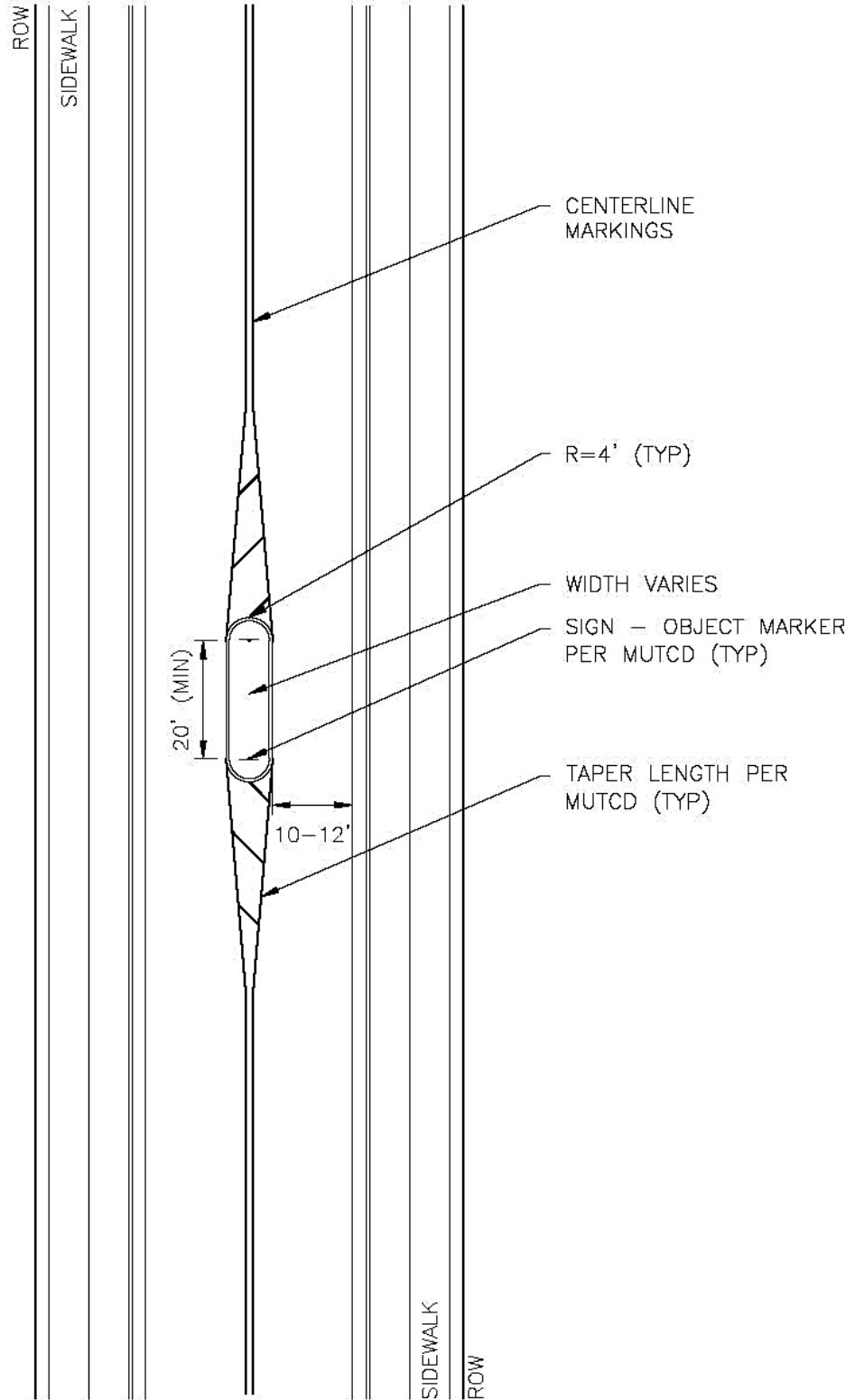

Raised Median Islands

**Figure 2.17**

## Section 2 Design Requirements for Transportation Facilities

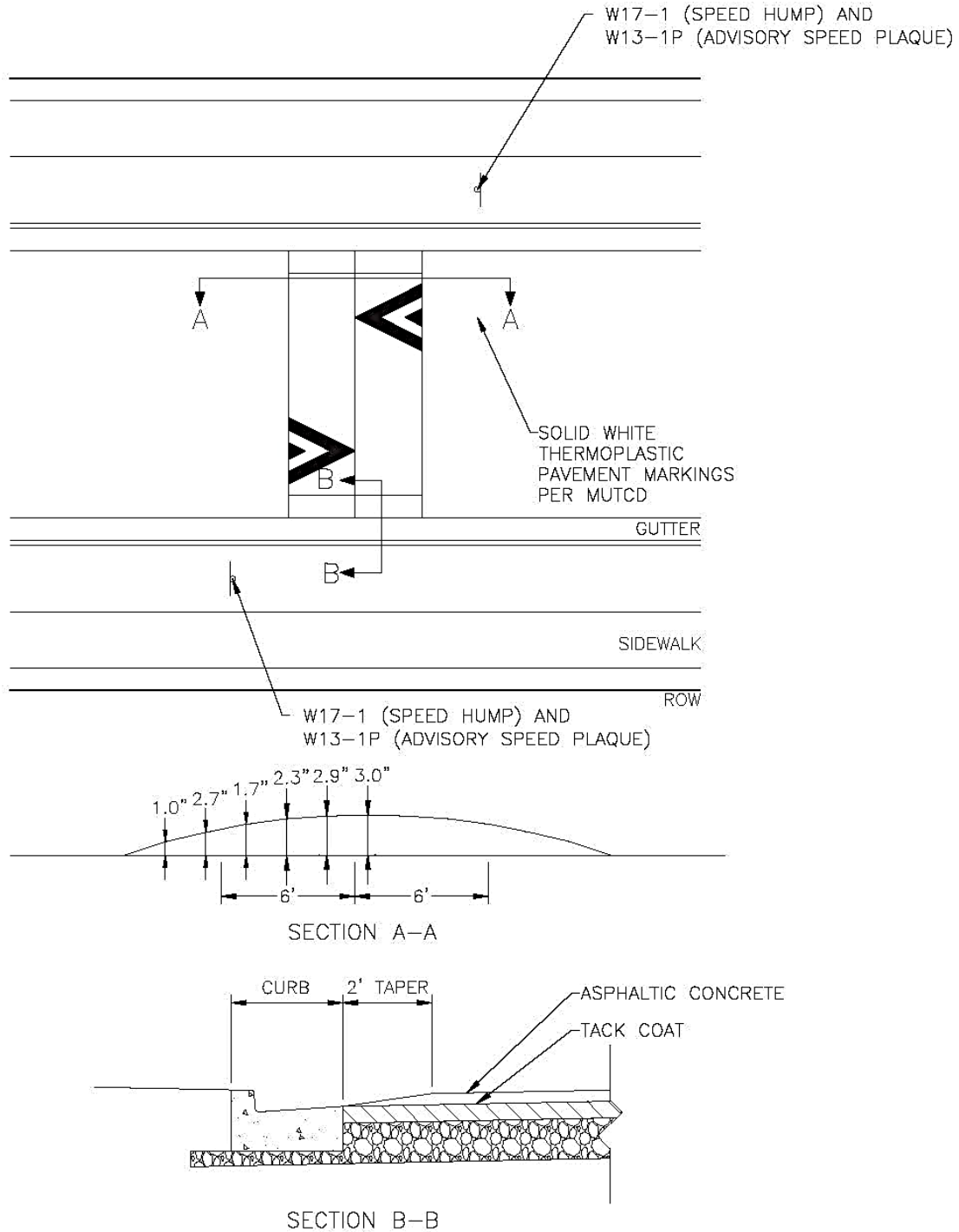

- 1) SIGNS AND MARKINGS SHALL BE IN ACCORDANCE WITH MUTCD & ITE PRACTICES.
- 2) ADVANCE SIGNING AT EACH LOCATION IS OPTIONAL WHEN PART OF AN AREA WIDE SCHEME.
- 3) CROSS-SECTION SHOWS APPROXIMATE ELEVATION FOR 3" (MAX) SPEED HUMP
- 4) SPEED HUMPS SHALL NOT BE PLACED OVER MANHOLES, VALVES, JUNCTION BOXES, ETC.
- 5) SPEED HUMPS MUST BE PLACED AT LOCATIONS APPROVED BY THE CITY ENGINEER
- 6) DESIGN SHALL BE MODIFIED TO ACCOMMODATE FIELD CONDITIONS (EX. DRAINAGE).

**Speed Hump**  
**Figure 2.18**

Section 2 Design Requirements for Transportation Facilities

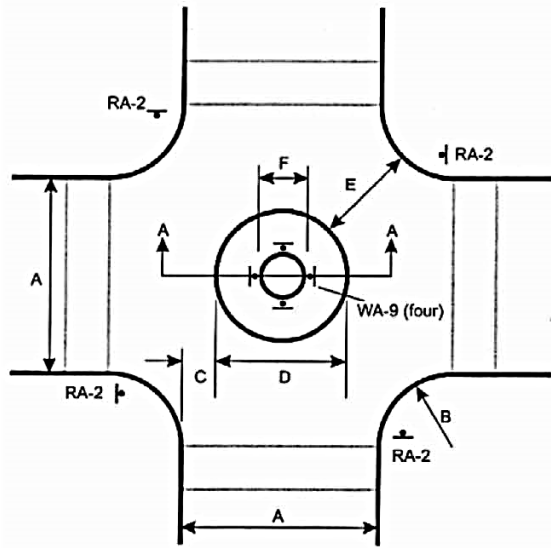

Sign Descriptions:  
 RA-2 Yield  
 WA-9 Chevron Alignment

Dimension Chart for Varying Roadway Widths				
A Roadway Widths	B Curb Return Radius	C Off-set Distance	D Circle Diameter	E Min. Opening Width
20	15.5	5.5	8.5	16.0
	17.5	5.0	9.0	16.5
	22.5	4.5	10.5	18.0
	26.5	4.0	11.5	19.0
24	14.0	5.5	12.0	16.0
	16.0	5.0	12.5	16.5
	21.0	4.5	14.0	18.0
	25.5	4.0	15.0	19.0
28	12.0	5.5	15.0	16.0
	14.0	5.0	15.5	16.5
	19.5	4.5	17.0	18.0
	24.0	4.0	18.5	19.5
32	10.5	5.5	15.5	16.0
	12.5	5.0	19.0	16.5
	17.5	4.5	20.5	18.0
	22.0	4.0	22.0	19.0
36	25.0	3.0	23.0	20.0
	10.0	5.5	22.0	16.5
	11.0	5.0	22.5	16.5
	16.0	4.5	23.5	18.0
40	20.0	4.0	25.0	19.0
	22.5	3.0	26.0	19.5
	11.0	5.0	26.0	17.0
	12.0	4.5	27.0	17.0
44	18.5	4.0	28.0	19.0
	22.0	3.0	29.5	20.0
	10.0	5.0	29.5	17.0
	13.0	4.5	30.0	18.0
48	17.0	4.0	31.5	19.0
	21.0	3.0	33.0	20.0
	10.0	5.0	29.5	17.0

Legend:	
A	Roadway Width
B	Curb Return Radius (10' min.)
C	Off-Set Distance (5' max.)
D	Circle Diameter
E	Opening Width (See Table above)
F	Raised Island Diameter (4' min.)

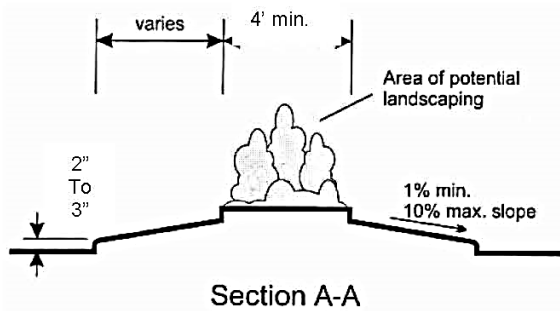

Minimum Opening width to be provided to all crosswalks  
 A deflection triangle painted on the pavement on each approach to the traffic circle may be appropriate.

**NOT TO SCALE**

Mini Traffic Circle  
**Figure 2.19**



**Section 3 Traditional Neighborhood Development (TND) Street Design**

Reserved

## **Section 4 Pavement Design**

The purpose of this Section is to present the City criteria and guidelines for the design and construction of pavements in accordance with criteria and standards established by IDOT and the City of Collinsville. The goal is to design and construct pavements that are free from defects and will provide superior long-term performance.

### **4.010 General**

This Section applies to all new and existing public street pavements within the City limits and the 1-1/2 mile extra territorial jurisdiction. The following general guidelines shall apply when designing and constructing pavements:

#### **4.010.01 Pavement Thickness**

New and reconstructed streets shall meet or exceed minimum thickness requirements established in this Manual.

#### **4.010.02 Pavement Design**

All pavement designs shall be in general conformance with the standards established by IDOT and this Manual.

#### **4.010.03 Pavement Type**

Streets are to be constructed of either asphaltic concrete or Portland cement concrete in conformance with the standards established by IDOT and this Design Manual.

### **4.020 Grading**

All grading necessary for the construction of pavement, curb and gutter, sidewalks, right-of-way and drainage facilities shall be done in a manner to assure there is a uniform subgrade with adequate bearing capacity to properly support the loading/structures to be superimposed.

All topsoil shall be removed from areas proposed for the construction of pavement, curb and gutter, or sidewalks; under no circumstances shall the improvements be constructed on topsoil or any other soil not capable of meeting the specifications for compaction specified in this Section.

Construction specifications. Work shall be completed according to the following sections in IDOT Standard Specifications:

- Section 201 for clearing;
- Section 202 for earth excavation;
- Section 204 for borrow and furnished excavation; and
- Section 205 for embankment.

## 4.030 Pavement Construction

### 4.030.01 Subgrades

The subgrade is the unimproved earth below the pavement structure, shoulders, or other appurtenances.

1. During construction the contractor is responsible to prepare subgrades that are properly graded to the lines and grades shown on the plans for the given project and in accordance with IDOT Standard Specifications Section 301, except as otherwise noted.
2. The standard laboratory density shall be a minimum 95% compaction as determined by ASTM Specification D-698A for clayey materials and minimum relative density of 95% as determined by ASTM D2049 for granular materials.
3. Compaction shall be achieved with a roller capable of properly compacting the given type of embankment material; in the case of fine-grained soils, a sheepfoot roller is required.

### 4.030.02 Subgrade Modification

Modification of the subgrade creates a working platform for construction equipment and enhances the strength of the subgrade. The City requires a chemical modification or mechanical modification of the subgrade.

Chemical modification can be accomplished by adding lime or cement to the subgrade, which increases the shear strength, reduces the plasticity index, and reduces the shrink swell potential of the soil.

Mechanical modification can be accomplished by covering the existing soil with granular material or partially removing and replacing wet subgrade with a granular material.

1. All City streets shall be constructed with an improved subgrade, which will consist of a twelve (12) inch thick layer of lime, cement modified subgrade, or aggregate granular material as recommended by a geotechnical engineer.
2. The Contractor is responsible for preparing modified subgrades that are properly graded to the lines and grades shown on the plans for the given project according to IDOT Standard Specification Section 302 except as otherwise noted.
3. If lime or cement modified soil is proposed, a mix design of the proportions of modifier, soil, and water is required. The mix design should be based on actual soil samples and prepared by a geotechnical engineer. Modifiers shall be proportioned with a range of two (2) to six (6) percent of the weight of soil based on the oven dry basis.

## Section 4 Pavement Design

4. Lime and cement modifiers shall not be applied when wind conditions are such that modifiers are blown on adjacent property or create a hazard to traffic on adjacent streets. In a densely developed area, the City Engineer may require lime or cement modifiers to be applied in a slurry form to avoid it from being blown by the wind.
5. The modifier shall be tilled into the soil with a rotary speed mixer.
6. Water and the modifier shall be directly injected into the soil with equipment capable of measuring the application rate to ensure adherence to the mix design.
7. If soil modification of the subgrade is not practical, the City Engineer may allow a twelve (12) inch thick granular subbase according to [Section 4.030.03](#).

### **4.030.03 Granular Subbase**

The subbase is the improved layer constructed on the prepared subgrade below the pavement. All City streets and sidewalks shall be constructed with a four-inch-thick minimum layer of granular subbase beneath the pavement.

1. Granular subbase shall be, "Subbase Granular Material, Type A," conforming to IDOT Standard Specifications Section 311, except as otherwise stated.
2. When constructing the subbase, if a soft spot in the soil subgrade is discovered, it shall be undercut to remove the unsuitable soft or spongy areas to the satisfaction of the City Engineer. The excavation shall be backfilled with CA-1 aggregate to bring the subject area back up to the subgrade elevation.
3. A suitable spreader box or paver shall be used to place the granular subbase, to avoid segregation.

### **4.030.04 Compaction Verification**

The contractor shall be responsible for providing soil testing results from an independent material testing firm to the City Engineer to verify compliance with compaction requirements listed in the IDOT Standard Specifications.

1. Soil tests shall be performed every one-hundred (100) feet of roadway with tests alternating between lanes, two hundred (200) foot intervals in each lane of traffic.
2. A written report from a registered professional engineer, certifying that soils throughout the embankment and subgrade material uniformly meet the compaction requirements, shall be provided to the City Engineer at least 24 hours prior to paving or pouring curb and gutter.

**4.030.05 Flexible Pavement**

All flexible pavements, for all streets and alleys, shall be constructed in accordance with the requirements set forth in [Table 4.1](#) with the provisions outlined in this Section, and with the standard specification plan sheets.

1. Should the City Engineer determine that the City's minimum pavement standards are not adequate for a given condition, a revised pavement design shall be proposed by the design engineer, subject to all provisions and procedures of the current pavement design which remain applicable, and subject to the review of the City Engineer. Conditions that affect the minimum pavement design include the following:
  - A. Vehicle volume,
  - B. Size of loads,
  - C. Truck volume,
  - D. Subgrade support, and
  - E. Drainage.
2. If a revised pavement design is required, it shall be according to Section 44-4 of IDOT's *"Local Roads and Streets Manual"*.
3. A bituminous prime coat shall be used on all granular subbases. No hot-mix asphalt shall be placed directly upon a granular subbase. Prime coat shall be according to IDOT Standard Specifications Section 406.
4. All hot-mix asphalt mixtures shall be manufactured in state-based plants and within the tolerance limits of the mixing formula provided by IDOT to the plants for the mixture. Warm-mix asphalt may be substituted for hot-mix asphalt; the warm-mix asphalt will be required to meet the applicable requirements of this Section and shall conform to IDOT Standard Specifications.
5. Hot-mix asphalt binder course shall conform to IDOT Standard Specification Section 406 and shall conform to the following mix design:
  - A. Asphaltic content/ performance grade (AC/PG): PG 62-22;
  - B. Thickness (min): overall thickness listed in [Table 4.1](#) exclusive of the surface course;

## Section 4 Pavement Design

- C. Reclaimed asphalt pavement (RAP)% (max): 10%;
  - D. Design air voids: 4.0% at Ndes=70;
  - E. Mix composition: IL-19.0; and
  - F. Friction aggregate: Mixture "B"
6. Hot-mix asphalt surface course shall conform to IDOT Standard Specification Section 406 and shall conform to the following mix design:
- A. AC/PG: PG 64-22;
  - B. Thickness (min): 1-1/2 inch;
  - C. RAP% (max): 10%;
  - D. Design air voids: 4.0% at Ndes=70;
  - E. Mix composition: IL-9.5; and
  - F. Friction aggregate: mixture "C".
7. Hot-mix asphalt pavement shall be laid with a self-propelled paver as specified in Section 407 of IDOT Standard Specifications to the thickness listed in [Table 4.1](#).
8. The minimum width of any single pass of the spreader/paver shall be capable of producing a lane width equivalent to half of the roadway width, with no single pass being less than 15 foot-wide in variable width areas such as cul-de-sacs.
9. The final surface course shall be placed so that following compaction the roadway surface is above the gutter flag by 1/4-inch.
- A. Care shall be taken to ensure that the final surface course properly meets drainage grates, manhole frames and valve boxes.
  - B. The final surface shall be neat and uniform in appearance.

## Section 5 Signal Design

Street Classification	Overall Thickness
Arterial	13 inch minimum design based on traffic estimates
Major Collector	10 inch minimum design based on traffic estimates
Minor Collector	9 inch minimum design based on traffic estimates
Local Industrial	9 inch minimum design based on traffic estimates
Local Commercial	8 inch minimum design based on traffic estimates
Local Residential	8 inch minimum design based on traffic estimates
Alley	6 inch minimum design based on traffic estimates

Structural Composition of Flexible Pavement

**Table 4.1**

### 4.030.06 Rigid Pavement

All rigid pavements, for all streets and alleys, shall be constructed in accordance with the requirements set forth in [Table 4.3](#) with the provisions outlined in this Section, and with the standard specification plan sheets.

1. Should the City Engineer determine that the City's minimum pavement standards are not adequate for a given condition, a revised pavement design shall be proposed by the design engineer, subject to all provisions and procedures of the current pavement design which remain applicable, and subject to the review of the City Engineer. Conditions that affect the minimum pavement design include the following:
  - A. Vehicle volume,
  - B. Size of loads,
  - C. Truck volume,
  - D. Subgrade support, and
  - E. Drainage.
2. If a revised pavement design is required, it shall be according to Section 44-4 of IDOT's *"Local Roads and Streets Manual"*.
3. Concrete admixtures shall conform to IDOT Standard Specification Section 1021; provided, however, that chloride-based accelerators shall not exceed 0.3% by mass.
4. The maximum haul time for concrete transported in truck mixers or truck agitators

Section 4 Pavement Design

shall be in accordance with [Table 4.2](#).

Concrete Temperature at Point of Discharge	Maximum Haul Time
50-64°F	1 hour, 30 minutes
65-90°F	1 hour (without retarder)
65-90°F	1 hour, 30 minutes (with retarder)

Concrete Haul Time

**Table 4.2**

5. Portland cement concrete shall be Class PV as specified in IDOT Standard Specification Section 1020.
6. When wire mesh is required for reinforcement, based on [Table 4.3](#), welded wire fabric conforming to AASHTO M55 shall be used. The wire fabric shall be:
  - A. Six (6) inches by twelve (12) inches with W4 wire transversely and W6.5 fabric longitudinally;
  - B. Lapped twelve (12) inches on the transverse laps and six (6) inches on the longitudinal laps; and
  - C. Placed on the subbase and supported by proper chairs and spacers prior to paving.
7. After the concrete has been finished and immediately after the water sheen has disappeared from the surface of the concrete, the surface shall be sealed with membrane curing compound as approved by IDOT. Under no circumstances shall polyethylene sheeting be placed on the pavement prior to initial set that would cause marking on the pavement surface.
8. The load transfer devices shall be:
  - A. Dowel bars that are smooth, plain and round conforming to the requirements of AASHTO M-227 grades 70 through 80.
  - B. Tie bars (deformed) conforming to the requirements of AASHTO M-31 grade 40.
9. The joint filling compound that is used shall be rubberized asphalt conforming to the requirements of AAHTO M-173.



## Section 5 Signal Design

10. When underlayment is required, it shall be one-fourth inch thick fabric such as “Bidmin”, “Petromat” or equal.
11. Portland cement concrete pavement shall be constructed according to IDOT Standard Specifications Section 420, except as modified:
  - A. The finishing machine shall be of a type approved by the City Engineer, and shall be capable of striking off, consolidating and finishing concrete to the consistency required by the specification to the proper crown and grade.
  - B. A mechanical longitudinal float will not be required.
  - C. Hand held fogging equipment capable of spraying a uniform application of membrane curing compound and maintaining constant pressure meeting the approval of the City Engineer, will be allowed.
  - D. Longitudinal float hand method will be permitted if approved by the City Engineer.
  - E. Type A final finish shall be used throughout the project unless directed otherwise by the City Engineer.
12. Prior to placing concrete on the subgrade/subbase, the grade shall be checked for proper depth with a template or a string line (if forms are used), or with before and after elevation shots for slip-form work.
  - A. Dry subgrades shall be made wet in advance of concrete placement.
  - B. Concrete shall not be placed on a frozen subgrade under any circumstance.
13. Concrete pavement shall be constructed to the thickness listed in [Table 4.3](#).
14. Plastic Portland cement concrete shall be deposited on the grade in successive batches as a continuous operation and in such a manner as to require minimal rehandling or segregation.
  - A. No batch/load shall be incorporated that has been in the truck longer than the maximum allowed haul time as listed in [Table 4.2](#).
  - B. The operation shall be coordinated so that the mixture is struck off and consolidated within 30 minutes of being deposited on grade.

## Section 4 Pavement Design

- C. Finishing floats shall be passed across the entire surface a minimum of two times with an overlap of 50% between successive locations along the pavement.

Street Classification	Thickness	Reinforcement	Transverse Joints	Longitudinal Joints
Arterial	10 inch minimum design based on traffic estimates	Wire Mesh Required	20 foot o.c. with 18 inch long no. 6 dowels every 12 inch o.c.	30 inch no. 6 tie bars every 30 inch o.c.
Major Collector	9 inch minimum design based on traffic estimates	Wire Mesh Required	18 foot o.c. with 18 inch long no. 6 dowels every 12 inch o.c.	30 inch no. 6 tie bars every 30 inch o.c.
Minor Collector	8 inch minimum design based on traffic estimates	None	15 foot un-doweled transvers construction joints	30 inch no. 6 tie bars every 30 inch o.c.
Local Industrial	8 inch minimum design based on traffic estimates	None	15 foot un-doweled transvers construction joints	30 inch no. 6 tie bars every 30 inch o.c.
Local Commercial	8 inch minimum design based on traffic estimates	None	15 foot un-doweled transvers construction joints	30 inch no. 6 tie bars every 30 inch o.c.
Local Residential	8 inch minimum design based on traffic estimates	None	15 foot un-doweled transvers construction joints	30 inch no. 6 tie bars every 30 inch o.c.
Alley	7 inch minimum design based on traffic estimates	None	15 foot un-doweled transvers construction joints	30 inch no. 6 tie bars every 30 inch o.c.

Structural Composition of Rigid Pavement

**Table 4.3**

15. Straight edge testing of plastic Portland cement concrete is required.
- A. After the operation of the slip-form paver, the finishing machine or the longitudinal float, but while the concrete is still plastic, the pavement surface shall be tested with a ten-foot straightedge.
- (1) High areas shall be cut down and refinished with a five (5) foot float.
- (2) The corrected areas shall be checked again with the ten-foot straightedge.
- B. The straightedge shall be held in successive positions parallel to the pavement

## Section 5 Signal Design

centerline in contact with the surface.

### 16. Pavement joints.

- A. All pavement joints shall be according to IDOT standard detail 420001-09.
- B. All bars shall be epoxy coated.
- C. All joints (transverse or longitudinal) shall be sealed with an approved hot-pour joint sealer according to IDOT Standard Specifications Sections 451 and 452, except the crack sealant shall be Crafcro Sealant or approved equal according to ASTM D5167.
- D. Contraction joints.
  - (1) All Transverse construction joints shall be:
    - a. Formed by means of a suitable header, accurately set and securely held in place in a plane perpendicular to the surface of the pavement.
    - b. "Tied" with no. 6 deformed bars, 30 inches long, spaced at 24 inch centers.
  - (2) When adjacent lanes of pavement or pavement and curb and gutter are constructed separately, epoxy-coated deformed steel tie bars across the longitudinal joint are to be installed across the longitudinal construction joint, as detailed in the standard specification plan sheets, in order to tie the lanes or the lane and curb and gutter together.
    - a. The epoxy coated tie bars shall be installed in preformed or drilled holes along the vertical edge of the first pour, using an approved non-shrink grout or chemical adhesive to provide a minimum pull requirement of 11,000 lbs. for no. 6 bars.
    - b. As an option, a trapezoidal metal joint type C (preformed keyway) as specified by IDOT and shown in the standard specification plan sheet may be utilized in lieu of tie bars.
  - (3) All construction joints must be at least five feet from a contraction joint.
- E. Sawed joints.
  - (1) The developer shall install longitudinal joints along the centerline of two-lane pavements, assuring that the joints are no closer than eight (8) feet and no farther than fifteen (15) feet apart according to IDOT standard detail 420001-09.
  - (2) The developer shall install transverse sawed contraction joints, consisting of planes of weakness created by cutting grooves in the surface of the

## Section 4 Pavement Design

pavement as specified in the IDOT standard detail 420001-09. Where specified in [Table 4.3](#), load transfer devices consisting of dowel bars supported on an approved dowel bar assembly shall be provided.

- (3) The joints shall be sawed within 24 hours of concrete placement or as soon as the concrete has hardened sufficiently to permit sawing without excessive raveling.

### F. Expansion joints.

- (1) To prevent street creep, type A3 four-inch seamless rubber expansion joints shall be installed as on IDOT Standard Detail 420001-09.
- (2) All entrances, driveways and accessways where concrete abuts the pavement or curb and gutter shall have a 3/4-inch thick pre-molded expansion joint at the interface of the street pavement (or back of curb) and driveway pavement, entrance pavement or accessway pavement. In addition, a 3/4-inch expansion joint shall be provided at all interfaces between the driveway or entrance pavement and proposed residential or commercial structure.

17. Following the application of the finished texture, and as soon as possible without marring the surface, the pavement shall be coated with membrane curing compound as required.

- A. Adequate and uniform coverage shall be achieved.
- B. Two separate applications at least one minute apart, each at the rate of not less than one gallon per 250 square feet will be required upon the surface.
- C. Type III compound shall be agitated immediately before and during the application.
- D. Membrane curing is not permitted where a protective coat or waterproofing is to be applied, or at any area where rubbing or a normal finish is required, or at construction joints other than those necessary in pavement or base course.
- E. Curing shall be maintained for a minimum of 72 hours.

18. When the National Weather Service forecast for the construction area predicts a temperature of 32°F or lower, or if the actual temperature is 32°F or lower, concrete that is less than 72 hours old shall be protected in the following manner:

- A. If the temperature is predicted to or falls between 25°F to 32°F, protection shall

## Section 5 Signal Design

consist of two layers of polyethylene sheeting or one layer of polyethylene sheeting and one layer of burlap, or two layers of waterproof paper.

- B. If the temperature is predicted to or falls below 25°F, protection shall consist of six inches of straw covered with one layer of polyethylene sheeting or waterproof paper placed after initial set of concrete.
19. Traffic shall be restricted on newly placed concrete streets by barricades and appropriate signs for a period of 14 days, provided that the City Engineer may increase the time period depending upon site location and conditions such as weather.
20. Whenever pavement is constructed after October 15 and it will be opened to traffic prior to the following April 15, or whenever directed to do so by the City Engineer, the developer shall apply a protective surface treatment consisting of two coats of boiled linseed oil mixture to the surface of the pavement and all appurtenances. The protective coat shall conform to IDOT Standard Specifications Section 1023 and shall be applied when the concrete is at least 14 days old and before the pavement is opened to traffic.

### 4.040 Curbing, Driveway Approach, and Sidewalk

#### 4.040.01 Residential Sidewalks

All residential street sidewalks within the City shall be constructed within the street right-of-way and shall meet all City requirements and IDOT standard drawings. The sidewalk forms and base material shall be inspected prior to concrete construction.

It is the contractor's responsibility to ensure safety and maintain access for pedestrians when sidewalks are under construction and to protect the in-place work from damage or vandalism.

Traffic control devices including cones, barrels and signs may be required on high volume streets to warn vehicular traffic in advance and adjacent to the area of construction.

1. All concrete sidewalks shall be a minimum uniform thickness of four (4) inches, except sidewalks shall be a the same minimum thickness of any approach when crossing a driveway or alley, using IDOT Class SI Sidewalk mix design with a minimum 28 day compressive strength of 3,500 psi. Sidewalks shall be constructed on 4 inches (minimum)of compacted, granular aggregate meeting FA-6, CA-6, or CA-10 gradation. The base aggregate shall be mechanically compacted to a firm, even surface in reasonably close conformity with the grade and cross section required.

## Section 4 Pavement Design

- A. All concrete admixtures used shall conform to IDOT Standard Specifications Section 1201.
- B. Calcium chloride shall not be added to concrete mixtures except during cold weather construction, and at that time shall not exceed 2%.
2. All Portland cement concrete shall be placed in an acceptable and workman like manner and at such a consistency that the plastic mixture is workable but does not exceed the slumps stated in IDOT Standard Specifications.
  - A. No batch/load shall be incorporated that has been in the truck longer than the maximum allowed haul time as specified in [Table 4.2](#).
  - B. The mixture shall be properly consolidated by vibrator or spading prior to or concurrently with the strike-off operation.
  - C. The mixture shall be worked sufficiently to bring 1/8 inch to 1/4 inch of mortar to the surface to allow for proper finishing.
  - D. Care shall be exercised to avoid segregating the mixture.
3. The sidewalk cross slope shall be 1.5% (2.0% maximum), sloping toward the curb. Longitudinal sidewalk grades within a street or highway right-of-way shall not exceed the general grade established for the adjacent street or highway. Pedestrian street crossings shall not exceed 5.0%.
4. For detached sidewalks, the difference in elevation between the top of sidewalk and the top of curb at any adjacent location shall not exceed the difference produced by a maximum 4:1 slope.
5. Sidewalks shall be installed utilizing metal or wood forms, straight and free from bend or warp, and that are clean and securely staked and braced prior to placement of concrete in order to prevent vertical movement during placement and finishing operations. Forms may deviate from true straightness over a 12-foot length no more than 1/2 inch horizontally, as determined with a string line.
6. Sidewalk surface is to receive a light broom finish, to achieve a sandy texture with texture lines perpendicular to traffic. Exposed aggregate sidewalk finishes are not acceptable within the street right-of-way.
7. All exposed concrete edges shall be rounded to a 1/2 inch radius.

## Section 5 Signal Design

8. Final longitudinal surface variations shall not exceed 1/4 inch under a 12-foot straight edge and transverse variation shall not exceed 1/8 inch in 5 feet. Low spots which allow water to pond will not be acceptable.
9. Following the application of the finished texture, and as soon as possible without marring the surface, the pavement shall be coated with membrane curing compound as required.
  - A. Adequate and uniform coverage shall be achieved.
  - B. Two separate applications applied at least one minute apart, each at a rate of not less than one gallon per 250 square feet will be required upon the surface.
  - C. Type III compound shall be agitated immediately before and during the application.
  - D. Membrane curing is not permitted where a protective coat or waterproofing is to be applied, or at any area where rubbing or a normal finish is required, or at construction joints other than those necessary in the sidewalk.
  - E. Curing shall be maintained for a minimum of 72 hours.
10. When the National Weather Service forecast for the construction area predicts a temperature of 32°F or lower, or if the actual temperature is 32°F or lower, concrete that is less than 72 hours old shall be protected in the following manner:
  - A. If the temperature is predicted to or falls between 25°F to 32°F, protection shall consist of two layers of polyethylene sheeting or one layer of polyethylene sheeting and one layer of burlap, or two layers of waterproof paper.
  - B. If the temperature is predicted to or falls below 25°F, protection shall consist of six inches of straw covered with one layer of polyethylene sheeting or waterproof paper placed after initial set of concrete.
11. Transverse control joints shall be spaced 5 feet maximum and shall be placed at right angles to traffic. Joints shall also be placed to intersect all inside or re-entrant corners. Joints shall be formed with a grooving trowel to a depth of 1 inch. The top edges of the grooves shall be rounded to 1/4 inch radius.
12. Longitudinal control joints are required for sidewalk widths greater than 6 feet. Two longitudinal joints are required for sidewalks greater than 10 feet. Longitudinal joints shall be centered in the width of the sidewalk.

## Section 4 Pavement Design

13. Expansion joints shall be constructed with 1/2 inch thick pre-molded rubberized expansion joint filler, bituminous fiberboard shall not be used. Expansion joint material shall extend the full width of the sidewalk and the depth shall extend to within 1 inch of the top surface. Space expansion joints at 30 feet maximum spacing and at each driveway and at any cold joint. Expansion joints are also required at the back edge of driveway approaches between the approach and the private drive and at each side interface with the sidewalk.
14. When sidewalks are adjacent to curved sections of the street curb and when a sidewalk is placed adjacent to buildings and/or retaining walls, 1 inch thick pre-molded expansion joints are required. Use 1/2 inch isolation joints around other fixed objects like utility poles, hydrants, and manholes. Use 1/2 inch expansion joints between the curb and sidewalks where constructed adjacent to each other.
15. All valve boxes, manhole covers and other castings in the sidewalk area shall be adjusted to the grade of the sidewalk.
16. Sidewalks and bikeways shall not be opened to pedestrian or bicycle traffic for at least 24 hours after placement. The contractor shall provide and maintain measures to restrict use during the curing period.
17. Concrete driveway aprons shall not be opened to vehicular traffic for at least seven (7) days after placement or until test cylinder breaks indicate an attained compressive strength of 2500 psi.
18. Backfill sidewalks flush with the surface of the walk and the surrounding ground line with soil. For detached sidewalks, backfill the area between the curb and the sidewalk on a straight line from the top of the walk to the top of curb, but not to exceed a 4:1 slope.

### **4.040.02 Commercial Sidewalks**

In addition to and including the above requirements for residential street sidewalks, commercial sidewalk widths shall be specifically reserved for pedestrian travel. Furniture, planters, and other protruding obstacles shall be kept clear a minimum required width of 4 feet. Obstacles in the pedestrian path shall be eliminated or a widened pathway around the obstacle will be required.

### **4.040.03 Bikeways**

Where desired, concrete bike paths within the City shall be constructed using the same requirements of commercial sidewalks except that control joints shall be saw cut 1-inch



## Section 5 Signal Design

deep through the concrete slab in lieu of tooled joints to improve rideability. Expansion joint material shall be recessed 1/2-inch minimum below the riding surface.

### 4.040.04 Handicapped Ramps

All sidewalks within the City shall include compliant handicapped access ramps at all intersections, crosswalks and commercial driveways when required by either the *Illinois Accessibility Code* or "*PROWAG*". Handicapped ramps shall be constructed in accordance with IDOT standard drawings.

1. Concrete for ramps shall be IDOT Class SI Sidewalk mix design with a minimum 28 day compressive strength of 3,500 psi and shall be finished by light broom finish texturing.
2. Install a 1/2-inch pre-molded, rubber expansion joint between the ramp section and the sidewalk and between the ramp section and the curb.
3. Truncated dome detectable warning areas shall be installed using ADA Solutions Cast-In-Place Replaceable Tactile Detectable Warning Panel or approved equal and shall meet the requirements of [Section 2.040.08](#).
4. The minimum concrete thickness for a handicapped ramp shall be 8 inches.

### 4.040.05 Driveway Approaches

A driveway approach is the portion of the driveway between the roadway or curb of any public street and the property line.

1. Residential Portland cement concrete driveway approaches shall be a minimum of six (6) inches thick. Approaches shall be constructed on four (4) inches (minimum) of compacted, granular aggregate meeting FA-6, CA-6, or CA-10 gradation.
2. Residential asphalt concrete residential driveway approaches shall be a minimum of five (5) inches thick. Approaches shall be constructed on four (4) inches (minimum) of compacted, granular aggregate meeting FA-6, CA-6, or CA-10 gradation.
3. All other driveway approaches, including multi-family three-units and above shall be constructed to the same pavement thickness as the street it accesses.

### 4.040.06 Curb and Gutter Sections

All concrete curb and gutter sections shall be constructed in accordance with details shown in IDOT standard drawings and the project plans. Curb openings will be located as shown on the approved plans and will be evaluated based on acceptable access control requirements by the City.

1. Concrete for all curb and gutter sections shall be IDOT Class SI for Curb, Gutter, Curb

## Section 4 Pavement Design

& gutter, Median, and Paved Ditch with a minimum 28 day compressive strength of 3,000 psi.

2. Curb and gutter sections shall be constructed on compacted stone aggregate base for residential and commercial streets.
3. Control joints for curb and gutter sections shall be spaced at a maximum of 10 feet.
4. Expansion joints are required at all tangent points in curved sections, between curbs and sidewalks and between curbs and other rigid objects such as buildings, catch basins, and driveway aprons.
5. Where curbs are attached to the sidewalk, expansion joint spacing shall match the spacing of expansion joints in the sidewalk.
6. Curbs and gutters shall be constructed to follow the geometry of the roadway unless noted otherwise on the plans. Curved sections of curb shall conform to the roadway geometry with smooth continuous curves with no chorded portions.
7. Flow lines of gutters shall be true to line and grade with no areas of ponding water. Final longitudinal surface variations shall not exceed 1/4 inch under a 12-foot straight edge.
8. Concrete finish for curb and gutter shall be a light broom finish with finish lines parallel to the flow of water.
9. Curb and gutter sections abutting aprons shall not be opened to vehicular traffic for at least 7 days after placement or until test cylinder breaks indicate an attained compressive strength of 2500 psi.

### 4.050 Stamped Concrete and Brick Pavers

#### 4.050.01 Stamped Concrete

For areas designated by the City, concrete finishing may incorporate imprinting or stamping and coloring of the exposed finish for improved aesthetics. Stamped concrete finishes are to be performed only by qualified contractors with a minimum of five-years of experience in commercial concrete stamping finishes. For projects with proposed concrete stamping, the proposed pattern, finish and color shall be submitted with related product data to the City Engineer for approval. Prior to construction, a mock-up sample of a minimum 4 square feet in size shall be constructed to demonstrate a typical finished product for review and approval by the City.

## Section 5 Signal Design

Concrete stamped areas may include color of the final surface by applying a colored antiquing release agent just after initial set of the concrete. Concrete may also contain a color additive provided the colorant additive is mixed at the batch plant and the color is completely dispersed in the concrete. After concrete Curing, the colored concrete surface shall be sealed with a clear sealer containing at 30% solids in a minimum of two coats. Alternate method of coloring the concrete surface may be submitted to the City Engineer for approval.

### **4.050.02 Concrete Unit Pavers**

While stamped concrete is the preferred method for aesthetic enhancement of concrete surfaces, concrete pavers may be used to create borders or bands within sidewalk areas. Pavers will not be allowed in areas subject to vehicular traffic unless otherwise approved by the City Engineer.

All paver units shall be concrete pavers installed over concrete mats with bituminous adhesives. Clay brick paver units shall not be used. Pavers subject to vehicular traffic shall be required to have a minimum of 10 inch thick poured concrete base with weep holes filled with bedding material and a 3/4 inch bituminous setting bed. All other pavers shall have a minimum of 4 inch thick poured concrete base with a 3/4 inch thick bituminous setting bed.

### **4.060 Inspection and Laboratory Testing**

All pavement installations and repairs will require the contractor to submit material testing certifications to the City Engineer. Materials shall meet the requirements found in IDOT Standard Specifications.

The City Engineer reserves the right to request any additional tests deemed necessary for acceptance.

It is the contractor's responsibility to ensure quality concrete meeting IDOT Standard Specifications is delivered and placed on the project. All quality testing of concrete shall be performed by an independent testing company approved by the City in accordance with **Section 1** of these specifications. All quality testing performed by the testing agency is subject to monitoring and review by the City Engineer to ensure established procedures are followed. Reports of testing shall be certified and submitted to the City within ten days of actual testing to document the quality control before final acceptance of the project. The contractor will be responsible for the costs associated with all testing and also re-testing due to failed acceptance tests.

Required tests for concrete construction to be performed by the testing agency include:

- Slump
- Yield
- Entrained air content
- Mix temperature
- Representative test cylinders.

## Section 4 Pavement Design

### **4.060.01 Testing Frequency**

One composite sample (4 test cylinders) for each day's pour of each concrete mix exceeding 5 cubic yards but less than 25 cubic yards plus one set for each additional 50 cubic yard or fraction thereof.

Concrete placement operations shall be inspected by on-site superintendent to ensure placement of the concrete meets requirements of IDOT Standard Specifications. On-site inspection is required to be documented by the contractor and recorded in a field book subject to review by the City Engineer.

## Section 5 Signal Design

### 5.010 Introduction

The purpose of this Section is to outline the City's review process for traffic signal plans and highlight basic design requirements for traffic signal installation and/or modernizations. This Section outlines plan and design requirements for the various stages of review and also discusses some basic design elements the City requires on traffic signal projects.

Traffic signal technology changes at a rapid pace; the City reserves the right to change its traffic signal standards and specifications at any time without advance notice.

### 5.020 Administration

#### 5.020.01 Signal Warrants

For the installation of traffic signals to be considered, the location must satisfy the warrants outlined in the most recent edition of the "MUTCD". In areas where significant changes in traffic conditions are expected to the development of the area, hourly volumes for 5 years after full buildout shall be estimated and compared with the "MUTCD" signal warrants. The growth rate utilized to estimate the future traffic volumes is subject to the review and approval of the City Engineer prior to its use. The satisfaction of a traffic signal warrant or warrants shall not in itself require the installation of a traffic signal. The City Engineer shall make the final recommendation regarding the location of any new traffic signal. For state routes within the City, IDOT and the City will review to make final decisions regarding signal warrants.

#### 5.020.02 Engineering Study

An engineering study will be required for all proposed traffic signal installations. The engineering study shall evaluate the effects of the proposed traffic signal progression. The engineering study shall include the estimation of future volumes and an analysis of the progression of traffic through the signal system, as defined by the City Engineer. The evaluation shall include any planned future traffic signal installations. The analysis shall be submitted to the City Engineer for review and shall include capacity analysis (using Synchro, HCM Cinema or other software as approved by the City Engineer), as well as time-space diagrams of the signal system. The study periods shall be the AM, midday and PM peak hours, although other time periods may be required. Signal timing optimization for a corridor may be required depending on transportation impact analysis.

#### 5.020.03 Signal Spacing

Signalized intersections shall be located to maintain progression of traffic along arterial streets. This normally entails relatively uniform spacing and sufficient distances between signals to allow vehicles to travel at reasonable speeds. Optimal spacing of traffic signals

## Section 5 Signal Design

is always the desire of the City. The optimal spacing is a function of the cycle length and the progression speed of traffic along the major street, but a general guideline is that signals should be placed at least a quarter of a mile apart. New signal locations shall be subject to spacing requirements on a case-by-case basis as determined by the City Engineer. Proposed signal locations not adhering to this spacing will be reviewed. The spacing requirements may be waived if the City Engineer determines that the proposed traffic signal will not significantly hinder the progression of traffic along the major street. If the proposed location is rejected, the City Engineer may require either the relocation of the proposed signal location, to better accommodate progression, or the evaluation of other alternatives, for management of the traffic generated by the side street/private access.

### **5.020.04 Private Benefit Signals**

Private benefit signals provide signalized access to private streets or developments. These signals are generally required when the property owners must improve access from their site onto the major street or facilitate movement between developments on opposite sides of the street.

If the Transportation Impact Analysis for a new development indicates that a traffic signal will be warranted within 10 years of full build-out, the City Engineer may require the inclusion of a traffic signal as a part of the development plan. The financial responsibility for these signals shall be in accordance with the arrangements made during preparation of the development plan. The time frame for installation is dependent on the traffic projections and subject to the discretion of the City Engineer. The site development plans will not be approved until provisions for the installation of the traffic signal or other alternative measures to enhance the safe movement of traffic through the intersection are included in the site plans.

### **5.020.05 Designer Prequalifications**

The design of traffic signals shall be performed by a qualified Engineer that is prequalified by IDOT to perform "Special Studies - Traffic Signals". At the request of the City, the design engineer may be required to provide copies of their most recent traffic signal design and/or modification projects to the City Engineer prior to their being assessed as qualified.

### **5.050.06 Intersection Design Study (IDS)**

An IDS must be prepared for any intersection that is proposed for the installation or modernization of traffic signals. Engineering work associated with the IDS will include topographical surveys, preparation of a base map, roadway geometric design, traffic signal layout and traffic signal phasing. The IDS shall include the traffic signal warrant study, detailed preliminary intersection and signalization design to meet present and future traffic needs, a list of needed rights-of-way, and a total project cost estimate suitable for budgeting purposes. An IDS that has been reviewed and approved by the

## Section 5 Signal Design

City Engineer is required prior to the submittal of traffic signal plans for review. If an IDS does not exist for the intersection, one shall be prepared as part of the project presentation stage of design (described in the following section). If an IDS exists and, at the discretion of the City Engineer, the traffic conditions at the intersection have significantly changed since the preparation of the IDS, an update of the IDS may be required.

### 5.030 Design Standards

#### 5.030.01 Referenced Standards

The design of traffic signals is under the jurisdiction of the City and shall conform to the requirements and specifications outlined in this Section. Traffic signal design on State highways in the City shall meet the requirements of the City as approved by IDOT. All traffic signal design shall conform to the requirements of the “MUTCD”, IDOT Standard Specifications and IDOT’s “Local Roads and Streets Manual”.

#### 5.030.02 Design Requirements

1. Internally Illuminated Street Name Signs – Temple Edge-Lit Internally-Illuminated LED Street Signs shall be installed on all mast arms. Signs shall have a green background and rigid mount back brace.
2. Vehicle Loop Detector
  - A. Each detector loop shall have its own saw cut (homerun for preformed loops) from the loop to the edge of pavement or to a handhole in the pavement
  - B. Inductive loop detectors shall be utilized when the detector loop is to be placed (saw cut) in an existing pavement or new bituminous course. Each detector loop shall have its own unit duct between the edge of pavement and the first handhole.
  - C. Preformed detector loops shall be utilized in projects involving new pavement consisting of Portland cement concrete. The preformed loops shall be placed in the substrate. Preformed detector loops do not require a unit duct run between the edge of pavement and the adjacent handhole.
  - D. Detector loops complete with separate lead in cable shall be used on all approach lanes except for exclusive right turn lanes that will operate with the associated through and/or left turn phases.
3. Signal Head Assembly
  - A. Shall be fabricated from cast aluminum. The signal housing shall be painted

## Section 5 Signal Design

federal yellow (Signal housing in the Uptown area, along IL-159 from Spring Street to Church Street, and along St. Louis Road from Main Street to National Terrace shall be painted gloss black).

- B. Backplates shall be furnished and attached to the signal head. All back plates shall be louvered on each of the four sides of the panel and fabricated from black ABS UV stabilized plastic sheet.
  - C. Bracket mounted signal heads shall be supported by mounting brackets consisting of assemblies of 1-1/2 inch standard pipe size. All members shall be either plumb or level, symmetrically arranged, and securely assembled. Construction shall be such that all conductors are concealed within the poles and mounting assembly.
  - D. Signal indications on mast arms shall be aligned per IDOT Standard Specifications.
4. Electrical Service Connection – Underground service connection shall be installed per IDOT Standard Specifications.
5. Vehicle Detectors (Infrared and GPS Activated Priority Control) – All traffic signal installations shall include dual GPS/infrared Opticom emergency vehicle priority control system complete with detectors, wiring and card in the cabinet (3M system).
- A. Adequate line-of-sight must be provided to allow the controller to cycle through the necessary clearance intervals (vehicular and pedestrian) so the requested emergency vehicle preemption interval is displayed as the vehicle arrives at the intersection.
  - B. The detector shall be placed on the mast arm 2 feet to the right of the far left mast arm mounted signal.
  - C. Confirmation beacons must be provided for each direction of emergency vehicle direction.
6. Cabinet/Controller – The following shall be required for all traffic signals:
- A. Actuated solid state digital controllers meeting the latest NEMA standards housed in an IDOT Type IV cabinet shall be required.
  - B. A separate “Transceiver – Fiber Optic” is required for each new signal controller or signal controller that is being modernized.



## Section 5 Signal Design

7. Pedestal Pole – shall be powder coated black with a square pedestal base and installed per IDOT Standard Specifications. Specialty poles and standards shall be required by the City Engineer in the Uptown area and throughout the St. Louis Road corridor area.
8. Cantilever Signal Support
  - A. Signal Support shall be Cantilever type and powder coated black. The installation of strain poles shall generally not be approved by the City and will be reviewed on a case by case basis by the City Engineer. Specialty poles and standards shall be required by the City Engineer in the Uptown area and throughout the St. Louis Road corridor area.
  - B. Combination mast arms and other equipment necessary to provide intersection lighting will be required for all new traffic signal installations and modernizations. Aluminum and painted mast arm/signal poles, luminaire arms, and extensions shall be used.
  - C. Any street light luminaire extensions (aluminum and painted) shall be approved by the City Engineer. A minimum of 30-foot luminaire mounting height and a minimum 15-foot luminaire arm (aluminum and painted) shall be used to mount the streetlight fixture. The attachment height for mast arm to pole shall be per approved shop drawings.
9. Countdown Pedestrian Signal, Push Button Post, Button and Sign
  - A. All items shall be in compliance with “MUTCD” and ITE specifications.
  - B. Pedestrian signals and pushbuttons shall be provided at all signals unless otherwise directed by the City Engineer. All pedestrian signals shall have both audible and vibrotactile walking indications.
  - C. Yellow 16-inch LED countdown pedestrian signal with visor and a clamshell/banding mounting system are required, with ADA pedestrian buttons for all standard pedestrian movements with marked crosswalks (Pedestrian signal housing in the Uptown area and the St. Louis Road corridor area shall be painted gloss black). Housing material shall be one-piece die-cast aluminum alloy.
  - D. Pedestrian buttons shall be the bulldog type with audio alert, LED light, and sign housing/back plate. The accessible push button system with voice messages

## Section 5 Signal Design

(APS) shall be used only where approved by the City Engineer.

10. Battery Back-up and Power Conditioner – An Uninterruptible Power Supply (UPS) System shall be provided at all new permanent traffic signal installations and all traffic signal upgrades and modifications.
11. Two 3-inch conduits (Schedule 40 PVC minimum) shall be used for wiring between the signal bases and the cabinet.
12. Pull box covers installed in the roadway shall meet or exceed IDOT standard Specifications.
13. Loop Lead-Ins shall be per IDOT Standard Specifications with the exception of providing a minimum 2-inch diameter conduit for better accessibility.
14. Designer shall be required to include provisions for new streets and widening projects to include conduit for future signal interconnects and pull boxes as required.
15. All shop drawings for signals are to be approved by the City Engineer prior to installation.

### **5.030.03 Traffic Signal System Requirements**

1. The installation of a fiber optic interconnect is required between signalized intersections that are within 1/2 mile of one another or if analysis indicates that the signals would benefit from signal coordination. A communications interface must be installed as a part of the project if one does not exist already. All traffic signal systems will use IP based communications protocols and equipment shall have IP addressable ports.
2. The City Engineer may require the installation of detection for the purpose of collecting traffic counts.

### **5.030.04 Electrical Requirements**

1. The traffic signal design shall conform to the National Electric Code.
2. Traffic signal equipment shall conform to NEMA standards.
3. Fiber optic interconnect shall include a copper tracer, pull string/jet line, marker tape and curb markers in all ITS conduit.

## Section 5 Signal Design

4. Power back up shall be provided at locations required by the City Engineer, with the ability to provide stop-and-go control for up to one hour.
5. The traffic signal plan shall include a continuous grounding plan for the intersection.
6. Double hand holes are required at all traffic signal cabinet locations.
7. Power disconnects shall be provided.
8. Service pedestals shall contain circuits and test switches for safety lighting and illuminated street name signs.

### 5.030.05 Construction

Traffic signal installations/modernizations shall be constructed in accordance with applicable section of the IDOT Standard Specifications.

### 5.030.06 Pedestrian Signals and Timings

The “*MUTCD*” identifies the situations in which pedestrian signals shall be used and the situations in which pedestrian signals shall not be used. Because one should assume that pedestrians will be present at all intersections in the City to some level, all signalized intersections shall be designed to accommodate pedestrians. Other locations that have high pedestrian volumes with marked crosswalks may also warrant the installation of a dedicated pedestrian actuated traffic signal, subject to review and approval of the City Engineer.

Bicyclists are required to follow the rules of the road, including those related to traffic signals. Therefore, signal timing and detection shall accommodate the needs of bicyclists. Traffic signal clearance intervals are recommended to be timed to provide bicyclists with sufficient time to react, accelerate, and proceed through an intersection on the clearance interval. Normally, a bicyclist can travel through an intersection under the same signal phasing arrangement as motor vehicles. However, special consideration of bicyclists’ needs may be necessary at multi-lane crossings and at acute angle intersections, which take longer to cross. The clearance interval shall take into consideration a bicyclist’s speed of 6-8 MPH, and a perception/reaction/braking time of one (1.0) second. Traffic detectors for traffic actuated signals are recommended to be set to detect bicycles.

There are various types of detector loops that can be used for bicycle lanes. Quadruple and diagonal quadruple loop detectors generally provide for bicycle detection, unlike standard loops, which are difficult to adjust to detect bicycles. Detectors shall be located in the bicyclist’s expected path of travel. When bicycle lanes are not present, pavement markings shall be used to indicate where bicyclists should position themselves in order to activate the signal detector.

## Section 5 Signal Design

The "*MUTCD*" and "*PROWAG*" standards shall be consulted regarding pedestrian signal timing; however, these documents contain some differences. Each of these documents shall be reviewed, and the most stringent requirements shall be applied when designing pedestrian signal timings.

## Section 6 Street Lights

### 6.010 Introduction

Adequate lighting shall be provided to ensure safe movement of persons in the public right-of-way, and to assist for security purposes. The primary purpose of streetlights is to illuminate the public traveled ways to a level and uniformity that provides for the safe passage of public traffic, both vehicle and pedestrian.

### 6.020 Ownership/Responsibility

In general, ownership shall be based on the roadway classifications as indicated below:

Decorative Street lighting placed in the Uptown Area, Collinsville Crossings Area, and the St. Louis Road Corridor Area shall be owned and operated by the City of Collinsville. All other street lights on local, collector, and arterial streets are owned and operated by Ameren Illinois or Southwest Electric Cooperative.

#### 6.020.01 Responsibilities Delineated

1. Developer/Property Owners' Association/Contractor Responsibilities:
  - A. Submit lighting plans for approval by the City of Collinsville.
  - B. Obtain a City of Collinsville electrical permit for City or Privately owned and operated streetlights.
  - C. Obtain Ameren Illinois's approval for street lighting systems that are to be owned and operated by Ameren Illinois.
  - D. Obtain Southwest Electric Cooperative's approval for street lighting systems that are to be owned and operated by Southwest Electric Cooperative.
  - E. Responsible for utility initiation charges and energy usage charges until City accepts ownership.
    - (1) Ownership for private development project occurs at the time the City of Collinsville releases all performance sureties. The Collinsville City Council must approve the lighting of the City owned part of the project prior to turn-over of maintenance and billing.
    - (2) Ownership of City capital projects occurs at the time the entire project is substantially complete and accepted by the City.
2. City of Collinsville Responsibilities:

## Section 6 Street Lights

- A. The City of Collinsville shall review and approve all street lighting through appropriate submittals in accordance with Site Plans, Preliminary Plats, Final Plats, Civil Construction Plans, Lighting Plans, and Lighting Calculations.
- B. The City of Collinsville shall inspect, review and approve final record drawings associated with the record lighting plans.
  - (1) Ameren Illinois owned and operated streetlights:
    - a. The City of Collinsville shall inspect streetlight locations as shown on the City approved construction documents.
    - b. The City of Collinsville shall coordinate with Ameren Illinois to specify the billing rate class for the new streetlight services.
  - (2) Southwest Electric Cooperative owned and operated streetlights:
    - a. The City of Collinsville shall inspect streetlight locations as shown on the City approved construction documents.
    - b. The City of Collinsville shall coordinate with Southwest Electric Cooperative to specify the billing rate class for the new streetlight services.
  - (3) City of Collinsville owned and operated streetlights:
    - a. The City of Collinsville shall inspect pole bases.
    - b. The City of Collinsville shall perform scheduled ditch/conduit inspections before ditches are closed.
    - c. The City of Collinsville shall perform scheduled foundation inspections before concrete is poured.
    - d. The City of Collinsville shall perform electrical inspections on the customer side of the meter.
    - e. The City of Collinsville shall perform final inspections before lights are connected to the Ameren Illinois or Southwestern Electric Cooperative system.

## 6.030 Design Guidelines

Street lighting systems will be implemented in such a way as to improve the development in which the system is serving. The specifics of each streetlight will be reviewed by the City, as outlined herein, to ensure that any proposed streetlight will enhance its surroundings and improve public safety while also optimizing energy efficiency and cost savings. The City of Collinsville has adopted the following basic lighting standards.

### 6.030.01 General Design Standards

All street lighting of public and private streets in the City shall be designed in accordance with these standards. Adjacent bikeways and pedestrian ways are to be included when associated with the public right-of-way.

1. Underground Electric Service

Street lighting shall be installed with underground electric service on all newly developed dedicated public streets in the City. Curb returns shall be installed after the installation of the electrical system, including underground vaults. The Developer is responsible for coordinating with the appropriate electric utility company for all aspects of electrical service.

2. Fixture Type

All luminaires shall have an LED light source. The City seeks to minimize light pollution and avoid distributing light into windows of residents. All fixtures shall include cutoff shields or other mechanisms so that the light levels outside of the right-of-way does not exceed levels stipulated by LEED for the lighting zone of the project. No luminaires shall have any blinking, flashing or fluttering lights or other illuminating device which has a changing light intensity, brightness or color, nor is any beacon light permitted, except those required for fire alarm and/or emergency systems.

3. Fixture Location

A. The final installation location and quantity of all streetlights shall be determined by detailed calculations, coordination with the appropriate electric utility company during design and approval of the City Engineer.

B. Poles may be located within landscaped areas or islands; however, to avoid conflicts with required trees, the location of poles shall yield to existing mature trees. Proposed trees shall be relocated to avoid conflicts with light standards.

C. Unless otherwise approved by the City Engineer all street lighting equipment, conduits and foundations shall be located in the street right-of-way.

## Section 6 Street Lights

- D. When locating proposed lighting, the designer shall avoid possible conflicts with above-ground and below-ground utilities.

### 4. General Layout Criteria

- A. A minimum of two lights shall be placed at every intersection with the exception of alleys. Intersections with alleys will only require one light.
- B. Signalized intersections may be lighted using combined streetlights and/or lighting located on the signal mast arms. A minimum of four lights shall be placed at every signalized intersection.
- C. Roundabout lighting shall be in accordance with recommendations of IES DG-19-08 *"Design Guide for Roundabout Lighting"*. Lighting shall make the roundabout visible from a distance and make key conflict areas more visible. If continuous roadway lighting is not present, transition lighting is to be provided.
- D. Railroad crossing lighting will conform to the latest version of FHWA's *"Railroad-Highway Grade Crossing Handbook"* and FHWA's *"Lighting Handbook"*. If considered a conflict, luminaire supports shall be placed in areas of accessibility.
- E. All bridge underpasses, where vehicles, pedestrians, or bicyclists may be present, shall require lighting.
- F. For sidewalks attached to the curb, streetlights shall be installed behind the sidewalk (in right-of-way or easement) with at least 2-foot clearance (1-foot clearance on Local Streets). Poles within the clear zone shall be breakaway design.
- G. For sidewalks detached from the curb, streetlights shall preferably be located between the curb and sidewalk and installed a minimum of 2-feet from the back of curb, and 2-feet clear from all walks (1-foot on Local Streets). Poles within the clear zone shall be breakaway design.
- H. On streets without curb and gutter, streetlights shall be placed no closer than ten (10) feet from the edge of the traveled way. Poles within the clear zone shall be breakaway design.
- I. On streets with medians, street trees shall not be placed within 30 feet of a streetlight. Understory trees shall be no closer than 15 feet to any streetlight. Poles within the clear zone shall be breakaway design.



## Section 6 Street Lights

### 6.030.02 Local and Private Streets

In addition to the General Design Standards, all street lighting on local and private streets in Ameren Illinois's service territory shall be LED and installed per Ameren Illinois's standard drawings; all street lighting on local and private streets in Southwest Electric Cooperative's service territory shall be LED and installed per Southwest Electric Cooperative's standard drawings. Ameren Illinois shall be responsible of operation and maintenance of all street lighting on local and private streets in their service territory. Southwest Electric Cooperative shall be responsible of operation and maintenance of all street lighting on local and private streets in their service territory.

Energy costs associated with lighting on public streets shall be the responsibility of the City of Collinsville.

Energy costs associated with lighting on private streets shall be the responsibility of an association of the development.

#### 1. Light Temperature

Street lighting within the City of Collinsville shall have a light temperature of 4000 Kelvin.

#### 2. Prescriptive Lighting Standards

All local and private streets shall have prescriptive lighting based on the following standards:

- A. Max spacing of light poles shall not exceed 300 feet with a clear line of sight within the right-of-way from one pole to the next (excluding landscaping).
- B. Street lighting shall be placed in every cul-de-sac bulb and at the end of every dead-end street (temporary or permanent).
- C. Streetlights shall be placed thirty (30) inches from curb face to center, in line with any street trees in the furnished zone between the sidewalk and the curb.
- D. Poles shall be placed a minimum of ten (10) feet from driveway aprons.
- E. Streetlight poles and foundations shall not be located over any other utility. When locating proposed lighting, the designer should avoid possible conflicts with above-ground and below-ground utilities.
- F. Streetlight poles shall be located along lot lines whenever possible.
- G. Streetlight mounting height shall be limited to 16 feet above finished grade.

## Section 6 Street Lights

Upon the request of any owner of property to which this subsection applies, the City Engineer may approve an alternative prescriptive lighting plan. In making this determination, the City Engineer may consider specific design constraints such as large lot subdivisions.

### **6.030.03 Collector and Arterial Streets**

In addition to the General Design Standards, street lighting on Collector and Arterial Streets shall meet the standards set forth in “*American National Standard Practice for Roadway Lighting*” (ANSI/IESNA RP-8-14, issued June 26, 2014, by the American National Standards Institute, Inc. (ANSI) and by the Illuminating Engineering Society of North America (IESNA), and related documents listed in Paragraph 1.4 or RP-8-14. RP-8-14 is considered a live document, so any supplemental revisions are to be adhered to unless otherwise directed by the City of Collinsville.

Roundabouts shall conform to the standards set forth in “*Design Guide Roundabout Lighting (ANSI/IESNA DG-19-08)*” or latest version thereof.

Trespass light shall be limited to values defined by LEED and shall be based on the lighting zone of the project. Lighting zones shall be as adopted by the Illuminating Engineers Society (IES) to describe the ambient lighting conditions/sensitivity of the area.

The street classification and lighting zones used on a project shall be approved by the City.

#### 1. Light Temperature

Street lighting within the City of Collinsville shall have a light temperature of 4000 Kelvin.

#### 2. Minimum Wiring Design

Street lighting within the City of Collinsville shall be designed as follows:

- A. All wiring methods, equipment and construction shall conform to the latest edition of the National Electrical Code adopted by the City of Collinsville.
- B. All splices to be approved solderless waterproof connectors of proper size.
- C. All empty conduits shall have a 1/4-inch nylon pull rope provided inside.
- D. All conduits shall be sealed with an approved duct seal. Conduits stubbed for future extensions shall be capped.

## Section 6 Street Lights

- E. All pull box covers shall be secured accordance with the standards of the applicable electric utility company.
- F. All streetlights equipped with a photocell control shall have the photocell oriented to the north.
- G. All wire shall be THHN A.W.G. with the minimum size being No. 8 in runs between poles; the minimum size shall be No. 10 in runs between junction boxes and fixtures.

### 3. Pull Box and Conduit Design

- A. All conduit to be used shall be a minimum of 2-inches in diameter, except from each streetlight to the adjacent pull box which may be 1-inch diameter PVC or metal, and shall have the following cover from top of conduit.
  - (1) Within sidewalk of parkway areas: 3-foot minimum with Schedule 40 PVC conduit.
  - (2) Within roadway areas: 3-foot minimum with Schedule 80 PVC conduit.
- B. All metal conduit and other metal parts shall be continuously bonded and grounded.
- C. All bends and/or offsets shall be made with factory sections and there shall be no more than three factory bend per conduit run.
- D. Junction boxes shall be located at the base of every pole and not more than 200-feet apart on long runs.
- E. Pull boxes shall be located with the center of the pull box a minimum of 18-inches from the face of the curb.
- F. When pull boxes are subject to vehicular traffic, they shall be set on concrete footings and have cast iron traffic covers, with a minimum H-20 load rating. A concrete ring shall be provided around the pull box per manufacturer's instructions for application in paved area.
- G. Provide a minimum of 18-inch vertical and horizontal clearance from all other utilities. When clearance cannot be provided concrete encasement shall be required.

## Section 6 Street Lights

H. Conduit shall be run parallel and perpendicular to the roadway.

### 4. Metering Requirements

A. All City owned and maintained streetlights shall be metered. A metering plan will be submitted as part of the lighting plan, and will show, at a minimum, all meter locations, wiring extents, and installed meter type(s).

B. In order to reduce long-term maintenance costs, the City requires the following:

(1) The City seeks to connect as many streetlights as possible to each power meter to minimize the total number of meters.

(2) The City will not accept ownership and maintenance of streetlights that are on the same meters as other non-street lighting electrical uses.

### 5. Other Requirements

A. New developments within an existing developed area shall provide the entire lighting system, including luminaires.

B. All streetlight systems shall be designed for 240-volt service unless approved by the City of Collinsville due to circumstances/availability.

C. The City seeks to minimize light pollution and avoid distributing light into the windows of residents. All fixtures shall include cutoff shields or other mechanisms so that light levels outside of the right-of-way do not exceed levels stipulated by LEED for the lighting zone of the project.

D. Any existing lighting system to be transferred to ownership of the City of Collinsville shall be compatible with LED retrofit fixtures. LED fixtures and bulbs shall be approved by the City Engineer.

E. Any streetlight installed shall be approved by the City of Collinsville.

F. All wiring shall be underground without prior approval from the City Engineer.

#### **6.030.04 Submission Requirements (Ameren Illinois or Southwestern Electric Cooperative Owned Streetlights)**

The following documentation shall be submitted for City of Collinsville review and approval prior to approval of the site civil construction plan.

Section 6 Street Lights

1. Lighting Plan
  - A. Location, type and height of all lighting
  - B. Clearly identified/labeled property lines, streets and sidewalks.

**6.030.05 Submission Requirements (City Owned Street Lights)**

The following documentation shall be submitted for City of Collinsville review and approval prior to approval of site plan and civil construction plan.

1. Lighting Plan
  - A. Location, type, and height of all lighting
  - B. Location, type, and wiring specifications of all power meters
  - C. Details on color, materials, lumen output, light output color (temperature), and wattage for all lighting fixtures
  - D. Grid spacing of calculation points on roadways shall be two transverse points per lane at each longitudinal point along one luminaire cycle. Maximum 16.4 feet between longitudinal points.
  - E. Maximum illumination at property line (for non-residential and multi-family projects only). This is on and off roadways.
  - F. Clearly identify/labeled property lines

The following charts shall be provided on the drawings of all lighting designs:

Street and Site Lighting Data

**Table 6.1**

Lighting Load Center "3" Load Rquirements					
Circuit Number	Line Watts	Amp Load	Volt Drop (%)	Circuit Brkr. Size	Lighting Contactor Size
<b>Total:</b>				<b>Main:</b>	

Section 6 Street Lights

Street and Lighting Data	
Development Standard:	
Land Use:	
Zoning District:	
Height of Proposed/Existing Building:	
Pole Height:	
Pole/Fixture Color:	
Color of Light (in Kelvin):	
Luminaire Wattage:	
Luminaire Volt-Amps:	
Luminaire Lumens:	
Luminaire Light Loss Factor (LLF):	
<p>The Lighting Plan has been designed to meet the City of Collinsville Standards, and the approval of the Planning Commission/City of Collinsville. Changes shall not be made to the approved Lighting Plan unless approved by the relevant department director or the Planning Commission. *Additional lines or tables may be added if multiple lighting styles are to be used in a development or as needed.</p>	

Load Center Load Requirements

**Table 6.2**

Luminaire Fixture	Mounting Height	IES Distribution Classification	Aim/Tilt Angle	Light Loss Factor	Lumens Used (Per Fixture)	Pole Height	Color Temperature	Photometric Curve Numbers

Lighting Design Input Data

**Table 6.3**

Calculation Summary							
Label	Calc Type	Units	Avg	Max	Min	Avg/Min	Max/Min

Calculation Summary

**Table 6.4**

## Section 6 Street Lights

Lighting plans shall be reviewed by City Staff through the Development Assistance Team (DAT).

### 2. Lighting Calculations

Calculations shall be submitted as part of a site plan or civil construction plan submission. The lighting calculations shall include:

- A. Horizontal illuminance (foot-candles) on pavement/sidewalk
- B. Vertical illuminance (foot-candles) along sidewalks and at pedestrian conflicts
- C. Veiling glare ( $L_{vmax}/L_{min}$ )
- D. Lighting layout with fixture isoline contours of illuminance on street level:
  - (1) 3 FC – Light Purple
  - (2) 2 FC – Red
  - (3) 1 FC – Light Blue
  - (4) 0.5 FC – Green
  - (5) 0.25 FC – Dark Blue
  - (6) 0.1 FC – Black
- E. Voltage drop for each branch circuit
- F. Lighting Design Input Data
  - (1) Fixture type
  - (2) Fixture mounting height
  - (3) Lumens/fixture used
  - (4) Distribution type
  - (5) Aim/tilt

## Section 6 Street Lights

(6) Color temperature

(7) Light Loss Factor (LLF)

- G. Include drawings that show the calculation grids (with results) with fixture lighting iso-contours (templates) and drawings that have lighting rendered with iso-contour lines.
- H. Calculations shall be performed in the latest version of AGI-32. Calculations shall be submitted on drawings that match construction drawings. Include a copy of the lighting calculation software input/calculation file of approval submittals and as installed calculations.

### 6.030.06 Light Levels

Lighting shall be designed to the recommendations of the Illuminating Engineering Society of North America for levels, uniformity, and veiling luminance. The illuminance/luminance shall take into account the roadway surface classifications (R-class). For most cases, the R<sub>2</sub> and R<sub>3</sub> classes will be acceptable.

The following tables are from IES RP-8-14 and IES DG-19-08. Any changes to IES documents supersede these values.

Street Classification	Pedestrian Area Classification	Avg. Luminance $E L_{avg}$ (cd/m <sup>2</sup> )	Avg. Uniformity Ratio ( $L_{max}/L_{min}$ )	Max. Uniformity Ratio ( $L_{max}/L_{min}$ )	Max. Veiling Luminance Ratio ( $LV_{max}/L_{min}$ )
Major/ Arterial	High	1.2	3.0	5.0	0.3
	Medium	0.9	3.0	5.0	0.3
	Low	0.6	3.5	6.0	0.3
Collector	High	0.8	3.0	5.0	0.4
	Medium	0.6	3.5	6.0	0.4
	Low	0.4	4.0	8.0	0.4

$L_{avg}$  – minimum maintained average pavement luminance

$L_{min}$  – minimum pavement luminance

$LV_{max}$  – maximum veiling luminance

Lighting Design Criteria

**Table 6.5**



Section 6 Street Lights

Functional Classification	Maintained Average Horizontal Illumination in Lux/FC on the Pavement based on Pedestrian Area Classification			$E_{avg}/E_{min}$
	High	Medium	Low	
Major/Major	34.0/3.4	26.0/2.6	18.0/1.8	3.0
Major/Collector	29.0/2.9	22.0/2.2	15.0/1.5	3.0
Major/Local	26.0/2.6	20.0/2.0	13.0/1.3	3.0
Collector/Collector	24.0/2.4	18.0/1.8	12.0/1.2	4.0
Collector/Local	21.0/2.1	16.0/1.6	10.0/1.0	4.0

Note: The High, Medium, and Low Pedestrian Areas are described in Section 5.1.1 of IES RP-8-14.

Illumination for Intersections

**Table 6.6**

Functional Classification	Maintained Average Horizontal Illumination in Lux/FC on the Pavement based on Pedestrian Area Classification			$E_{avg}/E_{min}$
	High	Medium	Low	
Major/Major	34.0/3.4	26.0/2.6	18.0/1.8	3.0
Major/Collector	29.0/2.9	22.0/2.2	15.0/1.5	3.0
Major/Local	26.0/2.6	20.0/2.0	13.0/1.3	3.0
Collector/Collector	24.0/2.4	18.0/1.8	12.0/1.2	4.0
Collector/Local	21.0/2.1	16.0/1.6	10.0/1.0	4.0
Local/Local	18.0/1.8	14.0/1.4	8.0/0.8	6.0

Note: The High, Medium, and Low Pedestrian Areas are described in Section 5.1.1 of IES RP-8-14.

Illumination for Roundabouts

**Table 6.7**

Maintained Illuminance Values for Walkways			
	$E_{avg}$ (lux/ft)	$EV_{min}$ (lux/ft)	$E_{avg}/E_{min}$
Mixed Vehicle and Pedestrian	20.0/2.0	10.0/1.0	4.0
Pedestrian Only	10.0/1.0	5.0/0.5	4.0

$E_{avg}$  – minimum maintained average horizontal illuminance at pavement

$E_{min}$  – minimum horizontal illuminance at pavement

$EV_{min}$  – minimum vertical illuminance at 1.5m above pavement

\*Horizontal only

Recommended Values for High Pedestrian Conflict Areas

**Table 6.8**

Maintained Illuminance Values for Walkways			
	$E_{avg}$ (lux/ft)	$EV_{min}$ (lux/ft)	$E_{avg}/E_{min}$
Pedestrian Only	5.0/0.5	2.0/0.2	4.0

$E_{avg}$  – minimum maintained average horizontal illuminance at pavement

$E_{min}$  – minimum horizontal illuminance at pavement

$EV_{min}$  – minimum vertical illuminance at 1.5m above pavement

Section 6 Street Lights

\*Horizontal only

Recommended Values for Medium Pedestrian Conflict Areas

**Table 6.9**

Maintained Illuminance Values for Walkways			
	$E_{avg}$ (lux/ft)	$E_{V_{min}}$ (lux/ft)	$E_{avg}/E_{min}$
Rural/Semi-Rural Area	2.0/0.2	0.6/0.06	10.0
Low Density Residential (2 or fewer dwelling units per acre)	3.0/0.3	0.8/0.08	6.0
Medium Density Residential (2.1 to 6.0 dwelling units per acre)	4.0/0.4	1.0/0.1	4.0

$E_{avg}$  – minimum maintained average horizontal illuminance at pavement

$E_{min}$  – minimum horizontal illuminance at pavement

$E_{V_{min}}$  – minimum vertical illuminance at 1.5m above pavement

\*Horizontal only

Recommended Values for Low Pedestrian Conflict Areas

**Table 6.10**

Maintained Illuminance Values for Walkways			
	$E_{avg}$ (lux/ft)	$E_{V_{min}}$ (lux/ft)	$E_{avg}/E_{min}$
Day	100.0/10.0	50.0/5.0	3.0
Night	40.0/4.0	20.0/2.0	3.0

$E_{avg}$  – minimum maintained average horizontal illuminance at pavement

$E_{min}$  – minimum horizontal illuminance at pavement

$E_{V_{min}}$  – minimum vertical illuminance at 1.5m above pavement

\*Horizontal only

References 1, 2, 3, and 4 in Annex D of IED RP-8-14 gives more background information on the design criteria.

Recommended Values for Pedestrian Portion of Pedestrian/Vehicle Underpasses

Table 6.10

### 6.040 Record Drawings

Project applicant or designee shall provide record drawings that depict construction to the City prior to the request for City acceptance.

For Ameren Illinois or Southwest Electric Cooperative owned streetlights, all fixture locations shall be on the record drawings.

## Section 6 Street Lights

For City of Collinsville owned streetlights, all service connection points, service panel parameters, conduit locations (including distance from face of curb and depth), and all fixture locations.

## Section 7 Traffic Signs and Markings

### 7.010 Signing

#### 7.010.01 Type and Location of Signs

The City Engineer shall make the final determination regarding the type and location of signing controls within the right-of-way. These controls shall include traffic control signs (regulatory and warning), street name signs, delineators, and permanent barricades.

#### 7.010.02 Design, Installation, and Maintenance

Permanent traffic control devices on public rights-of-way and private streets shall be fabricated and installed in accordance with this Section, the latest revision of the “MUTCD” and IDOT Standard Specifications.

Bicycle facilities shall be designated with signing. AASHTO’s “*Guide for the Development of Bicycle Facilities*” and the “MUTCD” shall be consulted in order to determine appropriate signing for new bicycle facilities. Signs should be used in moderation in order to avoid distracting street users. When signs are used, they shall be highly visible and easily understood by all street users. Signs that are directed at bicyclists are smaller versions of standard street signs. This is because bicyclists typically travel at slower speeds than motorists and are typically closer to the signs than motorists are. Standard street signs that are directed at motorists also apply to bicyclists.

#### 7.010.03 Sight Visibility Standards for Traffic Control Signs

These standards are to provide for tree placement and configuration of City streets such that adequate sight distance is provide for traffic control signs. Typical sign types would be mid-block warnings, speed limit signs and stop signs. The recommended standards recognize that different criteria are needed for different travel speeds.

1. On streets designated with a speed limit of 20 MPH or 25 MPH, the first tree in front of the sign is to be placed a minimum of forty-five (45) feet before the sign.
2. On streets designated with a speed limit of 30 MPH, the first tree in front of the sign is to be placed a minimum of sixty (60) feet before the sign.
3. For trees exceeding ten (10) feet of canopy vertical clearance from the ground, the first tree in front of the sign is to be placed a minimum of twenty-five (25) feet before the sign.
4. Where signs are placed at the front end of curb extensions or bulb-outs, the above tree placements do not apply.

**7.010.04 New Street Signing**

Permanent signing, unless otherwise approved by the City Engineer, shall be completely in place before any new street is opened to the public.

**7.010.05 Other Standards**

These Standards are to be used in conjunction with other applicable City Regulations. The City Engineer may allow the installation of decorative posts and sign frames. In these cases, the developer, homeowners association or other responsible entity shall be responsible for the maintenance of these special installations. Decorative traffic supports, whether city-provided or developer-provided shall be black or dark green in color.

**7.010.06 Sign Posts, Supports, and Mountings**

Sign posts, supports and mountings shall comply with IDOT Standard Specifications and reviewed on an individual basis. Posts must be of appropriate length to comply with the "MUTCD" and IDOT Standard Specifications.

**7.010.07 Sign Reflectivity**

All traffic control signs must be fabricated with reflective materials. All reflective materials must qualify as High Intensity Grade for all signs except those signs for schools, pedestrians and overhead street name blades. For these signs, Diamond Grade sheeting shall be used. All signs or traffic control devices must have a minimum 7-year materials warranty.

**7.010.08 Sign Blanks**

Aluminum blanks of 0.080 gauges are standard, except for signs larger than 30 inches by 30 inches, which shall be 0.125-gauge aluminum.

**7.020 Pavement Marking and Striping**

**7.020.01 Type and Location of Striping and Markings**

The City Engineer shall make the final determination regarding the type and location of pavement striping and marking within the right-of-way during the review of the project signing and striping plans. All pavement marking on public and private roadways shall be specified and installed in accordance with this Section; all designs shall be in accordance with this Section, the "MUTCD" and IDOT Standard Specifications.

Bicycle facilities shall be designated with pavement markings. AASHTO's "Guide for the Development of Bicycle Facilities", the "MUTCD" and NACTO's "Urban Bikeway Design Guide" shall be consulted in order to determine appropriate pavement markings for new bicycle facilities. A bike lane shall be separated from motor vehicle travel lanes by a solid white line that is six (6) wide. The width of this line can be increased to eight (8) inches for added distinction. If on-street parking is present, a four (4) inch wide solid white line shall be used to separate the bike lane from the parking lane.

**7.020.02 Design, Installation, and Maintenance**

Permanent striping and marking, unless otherwise approved by the City Engineer, shall be completely in place before any new street is opened to the public. For streets opened to traffic prior to final surfacing and striping, the use of reflectorized paint installed to permanent standards at the end of each day's work shall be allowed. In addition, pavement markings shall be updated as needed to comply with IDOT Standard Specifications, the "MUTCD" and NACTO's "Urban Bikeway Design Guide".

New striping on new streets, overlays, and chip seals, etc. will require Extruded or Ribbon-Dispensed Thermoplastic Pavement Markings. Spray Thermoplastic Markings will be evaluated on a case by case basis by the City Engineer. As an alternate, the Contractor may apply preformed thermoplastic markings material for stop bars, cross walks, legends, or directional arrows. All pavement markings shall be installed per IDOT Standard Specifications.

Permanent striping and marking on the roadway centerline shall be installed on each segment of roadway construction within one Calendar Day of placing the final lift of asphalt concrete pavement on that roadway segment. New traffic striping of lane lines, crosswalks and stop bars (skip and solid white) shall be installed on each segment of roadway construction within two Calendar Days of placing the final lift of asphalt concrete pavement on that roadway segment.

**7.020.03 Crosswalks**

Crosswalks shall be used at all signalized intersections, approved crossings, school routes, adjacent to schools, and as otherwise directed. Mid-block crossings shall be approved on a case-by-case basis subject to an engineering study as approved by the City Engineer. Standard Crosswalk Configuration shall consist of two parallel twelve (12) inch lines spaced 10-foot apart and shall be used for all crosswalks on local roads unless otherwise approved by the City Engineer. Standard Crosswalk Configuration shall consist of 10-foot minimum width and 24-inch wide "Continental" style bars and shall be used for all crosswalks on all collector and arterial roads unless otherwise approved by the City Engineer. Where concrete pavement is present, the specific manufacturer's primer must be applied as per manufacturer's specifications.

## Section 8 Storm Drainage Facilities and Sediment Control

### 8.010 General

Stormwater sewers or channels provide the facility for removing and transporting surface runoff produced from rainfall. Design requirements differ from those for sanitary sewers.

This Section gives the minimum technical design requirements of the City storm drainage facilities. In general, the formulae presented herein for hydraulic design represent "acceptable" procedures not necessarily to the exclusion of other sound and technically supportive formulae. Any departure from these design requirements should be discussed before submission of plans for approval and should be justified. All construction details pertaining to storm sewer improvements shall be prepared in accordance with the "Standard Specifications for Water and Sewer Construction in Illinois" or "Illinois Standard Specifications for Road and Bridge Construction," unless otherwise noted.

### 8.020 General Requirements of Storm Sewer Construction

All storm sewers shall meet the following requirements:

#### 8.020.01 Size and Shape

The minimum storm sewer size shall be 12 inches for the first pipe reach (except when using pipe as a releasing control device for upstream pipe detention) and greater than or equal to the preceding reach for all subsequent reaches unless approved by the City Engineer. Circular pipes are preferred for storm sewers, although rectangular and elliptical conduits may be used with special permission.

#### 8.020.02 Materials

All materials shall conform to the current "*Illinois Department of Transportation Standard Specifications for Road and Bridge Construction*" or "*Standard Specification for Water and Sewer Construction in Illinois*".

#### 8.020.03 Bedding

The Project Plans and Specifications shall indicate the specific type or types of bedding, cradling, or encasement required in the various parts of the storm sewer construction if different than current the "*Standard Specification for Water and Sewer Construction in Illinois*".

Special design and bedding provisions shall be made for pipes laid within fills or embankments and/or in shallow or partial trenches, either by specifying extra strength pipe for the additional loads due to differential settlement, or by special construction methods, including ninety percent (90%) modified proctor compaction of fill to prevent or minimize such additional loads. Special considerations shall be made for pipe material

## Section 8 Storm Drainage Facilities

and bedding for unsuitable soil conditions or other conditions within the project area that may affect the pipe design.

Compacted granular backfill shall be required in all trench excavation within public (or private) streets rights-of-way or areas where street rights-of-way are anticipated to be dedicated for public use. Under areas to be paved, the compacted granular backfill shall be placed to within two (2) feet of the finished surface, and generally not more than two (2) feet beyond street pavement or curb lines. For new residential site developments, in areas outside of street right-of-way, where private driveways are not yet constructed, granular backfill will not be required.

In situations where fill is being added, minimal cover is proposed, or the sewer is being subjected to additional live or dead load, the design engineer shall provide structural calculations to verify the sewer is able to support the proposed loading.

### **8.020.04 Concrete Pipe or Conduit Strengths**

Reinforced Concrete pipe shall be Class II, minimum. Any concrete pipe, conduit or culvert beneath a street right-of-way, or with reasonable probability of being so located, shall be a minimum of Class III, but also shall account for all vertical loads, including the live load required, in no case shall the design provide for less than HS-20 loading of the AASHTO.

### **8.020.05 Monolithic Structures**

Monolithic reinforced concrete structures be designed structurally as continuous rigid units. Generally these are poured in place units. Wall thickness shall be 8" minimum with one row of reinforcement, horizontal and vertical. Wall thickness 10" and greater shall require 2 rows of reinforcement, horizontal and vertical. (Where approved MSD and IDOT precast structures are allowed, less steel and thickness may be accepted).

### **8.020.06 Alignment**

Sewer alignments are normally limited by the available easements, which in turn should reflect proper alignment requirements. Since changes in alignment affect certain hydraulic losses, care in selecting possible alignments can minimize such losses and use available head to the best advantage.

Sewers shall be aligned:

1. To be in a straight line between structures, such as manholes, inlets, inlet manholes and junction chambers, for all pipe sewers thirty (30) inches in diameter and smaller.
2. To be parallel with or perpendicular to the centerlines of straight streets unless otherwise unavoidable. Deviations may be made only with approval of the City.



## Section 8 Storm Drainage Facilities

3. To avoid meandering, off-setting and unnecessary angular changes.
4. To make angular changes in alignment for sewers thirty (30) inches in diameter or smaller in a manhole located at the angle point, and for sewer thirty-three (33) inches and larger, by a uniform curve between two tangents. Curves shall have a minimum radius of ten times the pipe diameter, with manholes as indicated in **8.020.08, item 1.**
5. To avoid angular changes in direction greater than necessary and any exceeding ninety (90) degrees.

### **8.020.06**      **Location**

Storm sewer locations are determined primarily by the requirements of service and purpose. Storm sewers are generally located so that manholes are not in the wheel path of travel lanes. It is also necessary to consider accessibility for construction and maintenance, site availability and competing uses, and effect of easements on private property.

Storm sewers shall be located:

1. To serve all property conveniently and to best advantage.
2. In public streets, roads, alleys, rights-of-way, or in utility easements dedicated to the City.
3. On private property along property lines or immediately adjacent to public streets, avoiding diagonal crossings through the central areas of the property.
4. At a sufficient distance from existing and proposed buildings including footings, and underground utilities or other sewers to avoid encroachments and reduce construction hazards.
5. To avoid interference between other storm sewers and house connections to sanitary sewers.
6. In unpaved or unimproved areas whenever possible.
7. To avoid, whenever possible, any locations known to be or probably to be beneath curbs, paving or other improvements particularly when laid parallel to centerlines.
8. Crossing perpendicular to streets, unless otherwise unavoidable.

## Section 8 Storm Drainage Facilities

### 8.020.07 Flowline

The flowline of storm sewers shall meet the following requirements:

1. The flowline shall be straight or without gradient change between the inner walls of the connected structures; that is, from manhole to manhole, manhole to junction chamber, inlet to manhole, or inlet to inlet.
2. Gradient changes in successive reaches normally shall be consistent and regular. Gradient designations less than the nearest 0.001 foot per foot, except under special circumstances and for larger sewers, shall be avoided.
3. Storm sewer depths shall be determined primarily by the requirements of pipe or conduit size, utility obstructions, required connections, future extensions and adequate cover.
4. Storm sewer pipes discharging into lakes shall have the discharge flowline a minimum of three (3) feet above the lake bottom at the discharge point or no higher than the normal water line.
5. A concrete cradle is required when the grade of a sewer is twenty percent (20%) or greater. A special design and specification is required for grades exceeding fifty percent (50%).
6. For sewers with a design grade less than one percent (1%), field verification of the sewer grade will be required for each installed reach of sewer, prior to any surface restoration or installation of any surface improvements.
7. The City may require the submittal of revised hydraulic calculations for any sewer reach having an as-built grade flatter than the design grade by more than 0.1%. Based on a review of this hydraulic information, the City may require the removal and replacement of any portion of the sewer required to ensure sufficient hydraulic capacity of the system.

### 8.020.08 Manholes

Manholes provide access to sewers for purposes of inspection, maintenance and repair. They also serve as junction structures for lines and as entry points for flow. Requirements of sewer maintenance determine the main characteristics of manholes. Cast in place or precast manhole structures are generally allowable, though the former requires approved shop detail drawings.

1. For sewers thirty (30) inches in diameter or smaller, manholes shall be located at changes in direction; changes in size of pipe; changes in flowline gradient of pipes, and at junction points with sewers and inlet lines.

## Section 8 Storm Drainage Facilities

For sewers thirty-three (33) inches in diameter and larger, manholes shall be located on special structures at junction points with other sewers and at changes of size, alignment and gradient. These special structures are identified as Junction Structures, and are described further in [Section 9.030.09](#). A manhole shall be located at each end of a short or long curve.

2. Spacing of manholes shall not exceed four hundred (400) feet for pipe sewers thirty-six (36) inches in diameter and smaller; five hundred (500) feet for pipe sewers forty-two (42) inches in diameter and larger, except under special approved conditions. Spacing shall be approximately equal, whenever possible.
3. When large volumes of stormwater are permitted to drop into a manhole from lines twenty-one (21) inches or larger, the manhole bottom and walls below the top of such lines shall be of reinforced concrete. Special structural design may be required for large pipes and/or large drops.
4. Manholes shall be avoided in driveways and sidewalks.
5. Connections to existing structures may require rehabilitation or reconstruction of the structure being utilized. This work will be considered part of the project being proposed.
6. When a project requires a manhole to be adjusted to grade a maximum of twelve (12) inches of rise is allowed if not previously adjusted. When adjustments to raise or lower a manhole is required, the method of adjustment must be stated on the project plans and approved by the City. Metal grade rings shall not be allowed.

### **8.020.09**      **Overflow/Design System**

The "design" components of the drainage system include the inlets, pipe, storm sewers, and improved and unimproved channels that function during typical rainfall events. The "overflow" system comprises the major overflow routes such as swales, streets, floodplains, detention basins, and natural overflow and ponding areas.

The purpose of the overflow system is to provide a drainage path to safely pass flows, which cannot be accommodated by the design system without causing flooding of adjacent structures.

The criteria for the design of the overflow and design systems shall be as follows:

1. The "design" system shall be designed in accordance with [Section 8.030, Stormwater Conveyance Systems Design Criteria](#).

## Section 8 Storm Drainage Facilities

2. The "overflow" system shall be designed for the 100-year, 20-minute event, assuming the "design" system is completely blocked. The capacity of the "overflow" system shall be verified with hydraulic calculations at critical cross-sections. The "overflow" system shall be directed to the detention facility, or as approved by the City.
3. The low sill of all structures adjacent to the "overflow" system swales shall be above the 100-year highwater elevation.
4. Where the topography will not allow for an overland flow path:
  - A. The storm sewer and inlet capacity shall be designed for the 100-year, 20-minute storm, and
  - B. If this storm pipe is smaller than thirty-six (36) inches in diameter, a designated ponding area shall be identified, assuming the pipe is blocked, and
  - C. The ponding area shall be based on the TR-55 100-year, 24-hour storm, and
  - D. The low sill of all structures adjacent to the ponding area shall be above the 100-year highwater elevation.
5. The "overflow" system and ponding areas shall be designated on the drainage area map and on the grading plan. Where overflow systems extend beyond the building setback areas, i.e. the overflow systems are closer to the house, sufficient separation shall be provided from locations where patios, swimming pools, decks, retaining walls, and other improvements are proposed or may be constructed by future end users.
6. All overflow systems will be considered on a site specific basis. Modifications to identified ponding areas and overland flow paths shall not be made without obtaining approvals from the City.

### 8.030 Stormwater Conveyance Systems Design Criteria

#### 8.030.01 Flow Quantities

Flow quantities are to be calculated by the "Rational Method" in which;

$$Q = API$$

where:

## Section 8 Storm Drainage Facilities

Q = runoff in cubic feet per second

A = tributary area in acres

I = average intensity of rainfall (inches per hour) for a given period and a given frequency

P = runoff factor based on runoff from pervious and impervious surfaces

P (Runoff Factors) for various impervious conditions are shown in [Table 8.1](#).

P.I. values for various impervious conditions are shown in [Table 8.2](#).

### 1. Rainfall Frequency

A fifteen (15) year rainfall frequency is to be used. In the design of local storm sewer systems, a twenty (20) minute time of concentration shall be used, unless drainage area and time of concentration dictates a different duration as indicated in item 3 below.

### 2. Impervious Percentages and Land Use

Minimum impervious percentages to be used are as follows:

- A. For manufacturing and industrial areas, 100%\*
- B. For business and commercial areas, 100%\*
- C. For residential areas, including all areas for roofs of dwellings and garages; for driveways, streets, and paved areas; for public and private sidewalks; with adequate allowance in area for expected or contingent increases in imperviousness:

In apartment, condominium and multiple dwelling areas: 75%\*

In single family areas:

1/4 Acre or less	50%
1/4 Acre to 1/2 Acre	40%
1/2 Acre to 1 Acre	35%
One acre or larger	Calculate impervious percentage*
Playgrounds (Non-Paved)	20-35%*

- D. For small, non-perpetual charter cemeteries, allow 30%

## Section 8 Storm Drainage Facilities

For parks and large perpetual charter cemeteries 5%

**\*NOTE:** Drainage areas may be broken into component areas, with the appropriate run-off factor applied to each component, i.e. a proposed development may show one hundred percent (100%) impervious for paved areas and five percent (5%) impervious for grassed areas. Use of actual component areas may be required where minimum impervious percentages are deemed misleading, or too approximate.

The design engineer shall provide adequate detailed computations for any proposed, expected or contingent increases in imperviousness and shall make adequate allowances for changes in zoning use. If consideration is to be given to any other value than the above for such development, the request must be made at the beginning of the project, must be reasonable, fully supported, and adequately presented, and must be approved in writing before its use is permitted.

Although areas generally will be developed in accordance with current zoning requirements, recognition must be given to the fact that zoning ordinances can be amended to change the currently proposed types of development, and any existing use. Under these circumstances the possibility and the probability of residential areas having lot sizes changed or re-zoned to business, commercial, or light manufacturing uses should be given careful consideration.

E. Average 20-minute values of P.I. (cfs per acre) to be used as follows:

<b>Percent Impervious</b>	<b>15-Year 20-Minute Duration</b>
5	2.05
10	2.20
20	2.48
30	2.71
40	2.93
50	3.16
90	4.12
100	4.34

\*Roofs 15-year 20-minute PI 5.64, 100-year 20-minute PI 7.59

\*When connected directly to sewer

### **3. Reduction in P.I. with Time and Area**

## Section 8 Storm Drainage Facilities

Reduction in P.I. values for the total time of concentration exceeding twenty (20) minutes, and for tributary areas exceeding three hundred (300) acres will be allowed only in trunk sewers and main channels. The reduced average P.I. value for the tributary area shall not be less than the value determined as follows on the basis of:

- A. Time. As the time of concentration increases beyond twenty (20) minutes, select the appropriate P.I. value from [Table 8.2](#). The travel time through a drainage channel should be based on an improved concrete section. These reduced values shall be used unless a further reduction is allowed for area.
- B. Area. As the total tributary area at any given location in a channel increases in excess of three hundred (300) acres, the P.I. value may be further reduced by multiplying it by an area coefficient "Ka". (The area coefficient is obtained from data in a special study of a major storm in the St. Louis area by the U.S. Corps of Engineers.) The average rainfall rate, for a given storm, for a given period for the tributary area, is less than the corresponding point value as determined from recording rainfall gauges. The curve data is as follows:

P.I. Coefficients Ka	
Area (Abscissas)	"Ka" (Ordinates)
300 to 449 Acres	1.00
450 to 549 Acres	.99
550 to 749 Acres	.98
750 to 999 Acres	.97
1000 to 1280 Acres	.96
1281 to 1600 Acres	.95
1601 to 1920 Acres	.92
1921 to 2240 Acres	.91

### 8.030.02 Hydraulic Grade Line for Closed Conduits

#### 1. Computation Methods

The hydraulic grade line is a line coinciding with (a) the level of flowing water at any given point along an open channel, **or** (b) the level to which water would rise in a vertical tube connected to any point along a pipe or closed conduit flowing under pressure.

The beginning point for hydraulic grade line computations for storm sewers shall be at least the higher of the inside top of the storm sewer two reaches downstream of the connection to the existing system or the hydraulic grade line computed for the existing

## Section 8 Storm Drainage Facilities

system. Field-verification shall also apply.

The hydraulic grade line shall be computed to show its elevation at all structures and junction points of flow in pipes, conduits and open channels, and shall provide for the losses and the differences in elevations as required below. Since it is based on design flow in a given size of pipe or conduit or channel, it is of importance in determining minimum sizes of pipes within narrow limits. Sizes larger than the required minimum generally provide extra capacity, however consideration must still be given to the respective pipe system losses.

There are several methods of calculating "losses" in storm sewer design. The following procedures are presented for the engineer's information and consideration.

It is expected that the design will recognize the reality of such "losses" occurring and make such allowances, as good engineering judgment requires.

### A. Friction Loss

The hydraulic grade line is affected by friction loss and by velocity head transformations and losses. Friction loss is the head required to maintain the required flow in a straight alignment against frictional resistance because of pipe or channel roughness. It is determined by the equation:

$$h_f = L \times S_h$$

Where:

$h_f$  = difference in water surface elevation, or head in feet in length L due to friction

L = length in feet of pipe or channel

$S_h$  = hydraulic slope required for a pipe of given diameter or channel of given cross-section and for a given roughness "n", expressed as feet of slope per foot of length

From Manning's formula:  $S_h = [V \cdot n / (1.486 R^{0.667})]^2$

Where:

R = hydraulic radius of pipe, conduit or channel (feet)  
(Ratio of flow area/wetted perimeter)

V = velocity of flow in feet per second (fps)

n = Manning's value for coefficient of roughness

Use:

n = 0.013 for concrete, vitrified clay, and PVC pipe



## Section 8 Storm Drainage Facilities

$n = 0.012$  for formed monolithic concrete, i.e., vertical wall channels, box culverts and for RCP over 48" in diameter

$n = 0.015$  for concrete lining in a ditch or channel inverts and trapezoidal channels

$n = 0.020$  for grouted riprap lining on ditch or channel side slopes

$n = 0.033$  for gabion walled channels

### Note:

"n" will have a weighted value for composite lined channels.

"n" values for unlined channels to be determined on an individual basis.

### B. Curve Loss

Curve loss in pipe flow is the additional head required to maintain the required flow because of curved alignment, and is in addition to the friction loss of an equal length of straight alignment. It should be determined from [Figure 8.2](#), which includes an example.

### C. Entrance Loss at Terminal Inlets

Entrance loss is the additional head required to maintain the required flow because of resistance at the entrance. The entrance loss at a terminal inlet is calculated by the formula:

$$H_{ti} = (V^2/2g)$$

Where:

V = velocity in flow of outgoing pipe

g = acceleration of gravity (32.2 ft/sec/sec)

### D. Turn Loss

Head losses in structures due to change in direction of flow (turns) in a structure, will be determined in accordance with the following:

<u>Change in Direction of Flow (A)</u>	<u>Multiplier of Velocity Head of Water Being Turned (K)</u>
90 Deg.	0.7
60 Deg.	0.55
45 Deg.	0.47
30 Deg.	0.35
15 Deg.	0.18
0 Deg.	0.0

## Section 8 Storm Drainage Facilities

Other Angles

By Interpolation

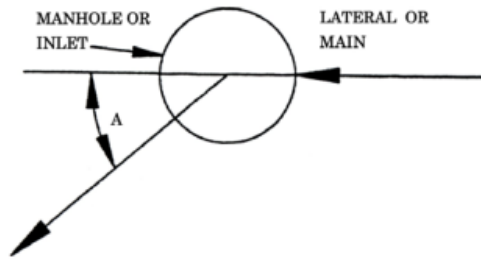

$$\text{Formula: } H_L = K(V_L)^2/2g$$

Where:

$H_L$  = Feet of head lost in manhole due to change in direction of pipe flow

$V_L$  = Velocity of flow in pipe in ft/sec

$g$  = Acceleration of gravity, 32.2 ft/sec/sec

$K$  = Multiplier of Velocity Head of water being turned

### E. Junction Chamber Loss

A sewer junction occurs for large pipes or conduits too large to be brought together in the usual forty two (42) inch diameter manhole or inlet where one or more branch sewers enter a main sewer. Allowances should be made for head loss due to curvature of the paths and due to impact at the converging streams.

Losses in a junction chamber for combining large flows shall be minimized by setting flowline elevations so that pipe centerlines (springlines), will be approximately in the same planes.

At junction points for combining large storm flows, a manhole with a slotted cover shall be provided.

A computation method for determining junction chamber losses is presented below:

$$H_j = y + V_{h1} - V_{h2}$$

Where:

$H_j$  = junction chamber loss (ft)

$V_{h1}$  = upstream velocity head

$V_{h2}$  = downstream velocity head

$y$  = change in hydraulic grade line through the junction in feet

## Section 8 Storm Drainage Facilities

Where:

$$y = \frac{[(Q_2V_2) - (Q_1V_1) + \{(Q_3V_3\cos\theta_3) + (Q_nV_n\cos\theta_n)\}]}{0.5(A_1 + A_2)g}$$

Where:

- $Q_2$  = Discharge in cubic feet per second (cfs) at the exiting conduit
- $V_2$  = Velocity in feet per second (fps) at the exiting conduit
- $A_2$  = Cross section area of flow in sq. ft. for the exiting conduit
- $Q_1$  = Discharge in cfs for the incoming pipe (main flow)
- $V_1$  = Velocity in fps for the incoming pipe (main flow)
- $A_1$  = Cross section area of flow in sq. ft. for the incoming pipe (main flow)
- $Q_3, Q_n$  = Discharge(s) in cfs for the branch lateral(s)
- $V_3, V_n$  = Velocity(ies) in fps for the branch lateral(s)
- $\theta_3, \theta_n$  = The angle between the axes of the exiting pipe and the branch lateral(s)
- $g$  = Acceleration of gravity, 32.2 ft/sec/sec

Where:

$\theta$  = is the angle between the axes of the outfall and the incoming laterals

### F. Losses at Junctions of Several Flows in Manholes and/or Inlets

The computation of losses in a manhole, inlet or inlet manhole with several flows entering the structure should utilize the principle of conservation of energy. This involves both the elevation of water surface and momentum (mass times the velocity head). Thus, at a structure (manhole, inlet or inlet manhole) with laterals, the sum of the energy content for inflows is equal to the sum of the energy content of the outflows plus the additional energy required by the turbulence of the flows passing through the structure.

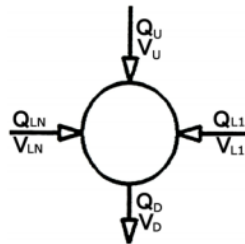

The upstream hydraulic grade line may be calculated as follows:

## Section 8 Storm Drainage Facilities

$$H_U = \left[ \frac{V_D^2}{2g} \right] - \left[ \left( \left( \frac{Q_U}{Q_D} \right) (1 - K) \left( \frac{V_U^2}{2g} \right) \right) + \left( \left( \frac{Q_{L1}}{Q_D} \right) (1 - K) \left( \frac{V_{L1}^2}{2g} \right) \right) + \left( \left( \frac{Q_{LN}}{Q_D} \right) (1 - K) \left( \frac{V_{LN}^2}{2g} \right) \right) \right] + H_D$$

Where:

- $H_U$  = Upstream hydraulic grade line in feet
- $Q_U$  = Upstream main line discharge in cubic feet per second
- $Q_D$  = Downstream main line discharge in cubic feet per second
- $Q_{L1}$ - $Q_{LN}$  = Lateral discharges in cubic feet per second
- $V_U$  = Upstream main line velocity in feet per second
- $V_D$  = Downstream main line velocity in feet per second
- $V_{L1}$ - $V_{LN}$  = Lateral velocities in feet per second
- $H_D$  = Downstream hydraulic grade line in feet
- $K$  = Multiplier of Velocity of Water being turned
- $g$  = Acceleration of gravity, 32.2 ft/sec/sec

The above equation does not apply when two (2) almost equal and opposing flows, each perpendicular to the downstream pipe, meet and no other flows exist in the structure. In this case the head loss is considered as the total velocity head of the downstream discharge.

### G. Transition Loss

The relative importance of the transition loss is dependent on the velocity head of the flow. If the velocity and velocity head of the flow are quite low, the transition losses can be minimal. The sewer design shall provide for the consideration of the necessary transitions and resulting energy losses. The possibility of objectionable deposits is to be considered in the design of transitions.

For design purposes it shall be assumed that the energy loss and changes in depth, velocity and invert elevation, if any, occur at the center of the transition. These changes shall be distributed throughout the length of the transition in actual detailing. The designer shall carry the energy head, piezometric head (depth in an open channel), and invert as elevations, and work from the energy grade line. Because of inherent differences in the flow, transitions for closed conduits will be considered separately from those for open channels.

#### (1) Closed Conduits

Transitions in small sewers may be confined within a manhole. Special structures may be required for larger sewers. If a sewer is flowing surcharged, the form and friction losses are independent of the invert slope;

## Section 8 Storm Drainage Facilities

therefore, the transition may vary at the slopes of the adjacent conduits. The energy loss in a transition shall be expressed as a coefficient multiplied by the change in velocity head ( $V^2/2g$ ) in which V is the change in velocity before and after the transition. The coefficient may vary from zero to one, depending on the design of the transition.

If the areas before and after a transition are known, it is often convenient to express the transition loss in terms of the area ratios and either the velocity upstream or downstream.

For an expansion:

$$H_L = \frac{K(V_1 - V_2)^2}{2g} \approx \left[ \frac{KV_1^2}{2g} \right] \left[ 1 - \left( \frac{A_2}{A_1} \right) \right]^2$$

In which  $H_L$  is the energy loss; K is a coefficient equal to 1.0 for a sudden expansion and approximately 0.2 for a well-designed transition and the subscripts 1 and 2 denote the upstream and downstream sections, respectively, i.e.,  $A_1$  = Area Before Transition and  $A_2$  = Area After Transition.

For a contraction:

$$H_L = \left[ \frac{KV_2^2}{2g} \right] \left[ \frac{1}{C_c} - 1 \right]^2 \approx \left[ \frac{KV_2^2}{2g} \right] \left[ 1 - \frac{A_2}{A_1} \right]^2$$

in which K is a coefficient equal to 0.5 for a well-designed transition,  $C_c$  is a coefficient of contraction, and the other terms and subscripts are similar to the previous equation. Losses in closed conduits of constant area are expressed in terms of ( $V^2/2g$ ).

The above equations may be applied to approximate the energy loss through a manhole for a circular pipe flowing full. If the invert is fully developed, that is, semi-circular on the bottom and vertical on the sides from one-half depth up to the top of the pipe, for the expansion ( $A_1/A_2$ ) = 0.88, and for the contraction ( $A_2/A_1$ ) = 0.88. The expansion is sudden; therefore,  $K = 1$ . The contraction may be rounded if the downstream pipe has a bell or socket. In this case, K may be assumed to be 0.2.

The expansion energy loss is  $0.014[V_1^2/2g]$  and the contraction energy loss is  $0.010[V_2^2/2g]$ . If the invert is fully developed, the manhole loss is small, but if the invert is only developed for one-half of the depth, or not at all, the

## Section 8 Storm Drainage Facilities

losses will be of considerable magnitude.

### (2) Open Channel Transitions

The hydraulics of open channel transitions are further complicated by possible changes in depth. As a first approximation to the energy loss, unless a jump occurs, the equations given above may be used with a trial-and-error solution for the unknown area and velocity. The K value for a well-designed expansion should probably be increased to 0.3 or 0.4. Whether the properties of the upstream or downstream section will be known will depend on the characteristics of the flow and the channel, but they can be determined by a profile analysis. In transitions for supercritical flow, additional factors shall be considered. Standing waves of considerable magnitude will be produced in transitions. The height of these waves must be estimated to provide a proper channel depth. In addition, in long transitions, air entrainment will cause bulking of the flow with resultant greater depths of the air-water mixture.

### 8.030.03 Hydraulic Grade Line Limits

The hydraulic grade line shall not rise above the following limits as determined by flow quantities calculated per [Section 8.030.01.1](#). Stormwater conveyance systems are usually designed for 15-year 20-minute rainfall frequencies per [Section 8.030.01.1](#).

1. The hydraulic grade line at any inlet or storm manhole shall not be higher than two (2) feet below the inlet sill or top of manhole, except where controlled by existing tail water conditions when sufficient overland flow path and ponding protection exist.
2. Storm sewer shall not flow with greater than three (3) feet of surcharged head.
3. The beginning point for the hydraulic grade line computations shall be the higher (i.e. more conservative) elevations as determined below:
  - A. For connection to existing pipe system:
    - (1) Top of the inside of the pipe of at least two reaches downstream of the connection point of the existing system; or
    - (2) The hydraulic grade line computed for the existing system. Note if the downstream system is surcharged, the elevation where flow exits the system should be considered.
  - B. For connection to channels or ditches:
    - (1) Top of the inside of the proposed pipe, or

## Section 8 Storm Drainage Facilities

(2) The hydraulic grade line computed for the channel or ditch as approved by the City.

C. For upstream system pipe connection to dry and wet detention basins the starting hydraulic grade line may be the 100-year 24-hour unblocked low flow water surface elevation.

4. When storm sewers are designed to convey 100-year flows, effusion at low lying inlets is not allowed, unless 100-year ponding easements are so delineated, granted, and recorded. Those associated temporary “ponding” easements however, should not be confused with 100-year overland flow paths, for which no conveyance area easements are presently required. Also, such intentional effusive designs may be prohibited for IDOT maintained streets or highways.

### 8.030.04 Inlets

Inlets function entirely as entry points for stormwater flow. They also may be constructed to serve as a manhole, and are then termed inlet-manholes. Steep gradients may give such low inlet capacities that additional inlets should be located at more favorable grade locations or special inlets designed for steep gradients must be used. Provision must be made to control by-pass flow and to provide additional capacity in the inlet and line affected by such increased flow. Six (6) inch open throat inlets should be used at all times. The open throat should not be obstructed or otherwise restricted by bars, weirs or screens.

Grated inlets, without an open throat or other provision for overflow shall be avoided except under exceptional conditions, and are prohibited in grade pockets. Any exceptions shall be used only with City approval.

Curb inlets shall be placed at street intersections or driveways such that no part of the inlet structure or sump is within the curb rounding.

1. Inlets are shown in “*Standard Specification for Water and Sewer Construction in Illinois*” and IDOT’s “*Highway Standards*”. The minimum depth of a terminal inlet is four (4) feet from the top of the inlet to the flowline of the outlet pipe. Greater depth shall be used for intermediate inlets if necessary for the required depth of the hydraulic grade line.
2. Inlet capacity should not be less than the quantity flow tributary to the inlet and bypass flow shall be avoided whenever possible. “Double inlets” may be used, if necessary for capacity. Bypass, if un-avoidable, must be identified, including amount and spread.

## Section 8 Storm Drainage Facilities

Inlets at low points or grade pockets should have extra capacity to compensate for possible flow by-pass of upstream inlets.

[Figure 8.3](#) shows inlet capacity/maximum gutter capacity with a given gutter line grade and flow. Inlets angled in opposition to direction of vehicular travel may be dangerous and are to be avoided.

3. Connections to existing structures may require rehabilitation or reconstruction of the structure being utilized. This work will be considered as part of the project being proposed.
4. Grated trough drains will not be accepted for dedication to the City.

### 8.030.05 Improved Channels

**\*NOTE: This Section contains some excerpts relating to design and are attributed to Open Channel Hydraulics by Ven Te Chow, a McGraw-Hill work published in 1959.**

In general, channelizing of natural streams shall be minimized, and shall meet all applicable requirements of the Corps of Engineers. Existing stream/channel fluvial geomorphological conditions shall be evaluated – not only within the project site, but also consideration given to impacts of the proposed improvement to the stream channel and appropriate mitigation counter measures taken as part of the design.

All improved channels shall meet the following requirements:

#### 1. Size and Shape

Improved channels shall not decrease in size in the direction of flow. Improved channels shall be vertical walled except in special cases where other approved materials are being considered.

#### 2. Materials

Channels may be constructed with reinforced concrete or other approved material. Gabions, articulated mattresses, or other systems may be approved. However, the City shall have the right to approve or disapprove any channel material and shall select the appropriate channel material if a proposed material is rejected. Swales shall be vegetated unless velocities are excessive (greater than 5 fps) or where velocities are less than 2 fps (causing deposition of sediment), then other materials may be used for the swale. Swales used as BMP's shall be appropriately vegetated and maintained, or otherwise stabilized in an approved manor.

#### 3. Bedding

Special provisions shall be made for channels or paved swales laid over fill on non-



## Section 8 Storm Drainage Facilities

supportive soils to support the channel or paved swales. Pipes extended to the channel in a fill area shall have compacted crushed limestone bedding for support.

### 4. Structural Considerations

Provision shall be made for all loads on the channel.

### 5. Alignment

Open channel alignments may be limited by available easements, physical topography, existing utilities, buildings, residential development, stormwater detention basins and BMPs, maintenance access and roadways.

### 6. Locations

Storm channel locations are determined primarily by natural drainage conditions. It is also necessary to consider accessibility for construction and maintenance, site availability and competing uses, and evaluating effects of easements on private property.

Storm channels shall be located:

- a. To serve all adjacent property conveniently and to best advantage.
- b. In easements or rights-of-way dedicated to the City.
- c. In easements on common ground when feasible.
- d. On private property along property lines or immediately adjacent to public streets, avoiding crossing through the property.
- e. At a sufficient distance from existing and proposed buildings, underground utilities, water mains, sewers, stormwater detention basins and BMPs to avoid future problems of flooding or erosion.
- f. To avoid interference between stormwater sewers and house connections to sanitary sewers.
- g. In unpaved or unimproved areas whenever possible.
- h. Crossing perpendicular to street, unless unavoidable.

### 7. Flowline

The flowline of open channels shall meet the following requirements:

## Section 8 Storm Drainage Facilities

- A. Gradient changes shall be kept to a minimum and be consistent and regular.
- B. Gradient designations less than the nearest 0.001 foot per foot shall be avoided.
- C. Channel and swale depths shall be determined primarily by the requirements of the channel size, utility obstructions and any required connections.

### **8. Other Improved Channel Considerations and Requirements**

- A. Drainage within private property should be controlled to prevent damage to the property crossed. Swales, or broad shallow grass lined ditches with non-erosive slopes, are generally located at or near rear lots and along common property lines. Where overflow systems extend beyond the building setback areas, i.e. the overflow systems are closer to the house, sufficient separation shall be provided from locations where patios, swimming pools, decks, retaining walls, and other improvements may be constructed by future end users. If a paved gutter or ditch is utilized, then appropriate erosion protection shall be used at both ends.
- B. Drainage channels and water courses draining through a subdivision may be enclosed if the required pipe size does not exceed sixty (60) inches unless a BMP plan is approved which incorporates the channel specifically. Drainage channels originating within a project site are encouraged to be incorporated into the development's stormwater management plan. When it is undesirable or impractical to enclose a channel with a pipe across a road or street, a suitable bridge or culvert shall be required.
- C. For flows greater than 4 cfs, area inlets or inlet manholes are required to intercept the gutter or swale flow unless part of a workable, recognized and approved BMP.
- D. All improved concrete channels shall have a forty eight (48) inch chain link fence on each side of the channel, or other protective measures as directed by the City.
- E. Improved channels draining large areas shall be located in rights-of-way or easements if applicable, as determined by the City, as part of an adequate overall plan for drainage.

### **9. Design Limitations**

- A. The flow quantity shall be calculated by the method presented in [Section](#)

## Section 8 Storm Drainage Facilities

[8.030.01](#) of this Manual.

- B. If the channel is within an area designated in a City of Collinsville or a County flood insurance study, then the channel shall also meet all City floodplain requirements.
- C. Other agencies of jurisdiction, such as FEMA or IDNR, may have requirements which must be met. A U.S. Army Corps of Engineers permit may be required for any construction affecting a watercourse.

### 10. Hydraulic Grade Line

#### A. Computation Methods

In improved channels the water surface is identical with the hydraulic grade line. The hydraulic grade line shall be computed throughout the channel reach to show its elevation at junctions with incoming pipes or channels and at the ends of the channel reach under consideration. It shall also provide for the losses and differences in elevations as required below. Since it is based on design flow in a given channel, it is of importance in determining minimum sizes within narrow limits. The depth at which the actual flows will occur is controlled by the two end conditions of the reach considered, and by the relationship between the energy available and by the energy required to overcome the losses that are encountered along the channel.

There are several methods of calculating “losses” in channel design. The following procedures are represented for the engineer’s information and consideration.

It is required that the design recognize the reality of “losses” occurring and make such allowances as good engineering judgement indicates.

#### (1) Control Sections

The engineer should locate all possible control sections for the reach in question. A control section refers to any section at which the depth of flow is known or can be controlled to a required stage. At the control section, flow must pass through a control depth which may be the critical depth, the normal depth or any other known depth. Three types of control sections include (a) Upstream Control Section; (b) Downstream Control Section; (c) Artificial Control Section, which occurs at a control structure, such as a weir, dam, sluice gate, roadway embankment, culvert, bridges or at the confluence with a major river or stream.

## Section 8 Storm Drainage Facilities

### (2) Friction Loss

The friction loss may be calculated by the same procedure as is presented in [Section 8.03.02](#) of these standards.

### (3) Flow in Curved Channels

The centrifugal force caused by flow around a curve produces a rise in the water surface on the outside wall and a lowering of the inner wall. This phenomenon is called superelevation. The flows tend to behave differently according to the state of flow.

In subcritical flow, friction effects are of importance, whereby in supercritical flow, the formation of cross-waves is of major concern.

#### i. Curve Losses

Curve losses may be estimated from [Figure 8.2](#) by replacing  $D$ , diameter, with  $b$ , width of channel.

#### ii. Superelevations

In addition to curve losses, an evaluation of superelevations should be considered and, if required, an allowance made in the top elevation of the outside wall. Equations are presented below which may be used to determine the superelevation at channel bends.

#### i. Trapezoidal Channels

Subcritical Flow:

$$\Delta H_w = 1.15(V^2/2gr_c)[b + D(ZL + ZR)]$$

Supercritical Flow:

$$\Delta H_w = 2.6(V^2/2gr_c)[b + D(ZL + ZR)]$$

#### ii. Rectangular Channels

Subcritical Flow:

$$\Delta H_w = (V^2b/2gr_c)$$

Supercritical Flow:

$$\Delta H_w = (V^2b/gr_c)$$

Where:

## Section 8 Storm Drainage Facilities

$\Delta H_w$  = Change in water height above the centerline water surface elevation.

$V$  = Average velocity of design flow in fps

$g$  = Acceleration of gravity (32.2 ft/sec/sec)

$r_c$  = Radius of curve on horizontal alignment in feet

$b$  = Base width of channel in feet

$D$  = Depth of flow in straight channel

$ZL$  = Left side slope (ft/ft)

$ZR$  = Right side slope (ft/ft)

### (4) Transitions

Transitions should be designed to accomplish the required change in cross section with as little flow disturbance as possible.

The following features are to be considered in design of transition structures.

#### a. Proportioning

For a well designed transition, the following rules should be used:

- i. The optimum maximum angle between the channel axis and a line connecting the channel sides between the entrance and exit section is  $12.5^\circ$ .
- ii. Sharp angles in the structure should be avoided.

#### b. Losses

The energy loss in a transition consists of the friction loss and the conversion loss. The friction loss may be estimated by the Manning Formula. The conversion loss is generally expressed in terms of the change in velocity head between the entrance and exit sections of the structure.

$$H_t = K_t \Delta V_H$$

Where:

$H_t$  = Conversion loss

$K_t$  = Coefficient of head loss in transition

$\Delta V_H$  = Absolute change in velocity head

## Section 8 Storm Drainage Facilities

Average design values for  $K_t$  are presented in the table below:

<u>Type of Transition</u>	<u>Contracting Section</u>	<u>Expanding Section</u>
Warped	0.10	0.20
Wedge	0.20	0.50
Cylinder-quadrant	0.15	0.25
Straight Line	0.30	0.50
Square End	0.40	0.75

See [Figure 8.4](#) for sketches of each type of transition.

c. Freeboard

A transition shall have a minimum of one (1) foot of freeboard above the hydraulic grade line.

d. Hydraulic Jump

The existence of a hydraulic jump in a transition may become objectionable, and the design of the transition should be checked for such.

e. Sudden Enlargement and Contraction

A sudden enlargement results when an intense shearing action occurs between incoming high-velocity jet and the surrounding water. As a result, much of the Kinetic energy of the jet is dissipated by eddy action. The head loss at a sudden enlargement,  $H_{Le}$ , is:

$$H_{Le} = K_e(\Delta V^2/2g)$$

Where:

$K_e$  = Coefficient of head loss for enlargements = 1

$\Delta V$  = Change in velocities between incoming and outgoing sections

$g$  = Acceleration of gravity (32.2 ft/sec/sec)

The flow in a sudden contraction is first contracted and then expanded resulting in high losses as compared to a sudden enlargement. Thus, the head loss at a sudden contraction,  $H_{Lc}$  is:

## Section 8 Storm Drainage Facilities

$$H_{Lc} = K_c(\Delta V^2/2g)$$

Where

$K_c$  = Coefficient of head loss for contractions = 0.5

$\Delta V$  = Change in velocities between incoming and outgoing sections

$g$  = Acceleration of gravity (32.2 ft/sec/sec)

### (5) Constrictions

A constriction results in a sudden reduction in channel cross section. The effect of the constriction on the flow depends mainly on the boundary geometry, the discharge and the state of flow. When the flow is subcritical, the constriction will induce a backwater effect that extends a long distance upstream. If the flow is supercritical, the disturbance is usually local and will only affect the water adjacent to the upstream side of the constriction. A control section may or may not exist at a constriction. The control section, when it exists, may be at either side of the constriction (upstream or downstream), depending on whether the slope of the constricted channel is steep or mild. The entrance and outlet of the constriction then acts as a contraction and an expansion, respectfully.

### (6) Obstructions

An obstruction in open-channel flow creates at least two paths of flow in the channel. Typical obstructions include bridge piers, pile trestles, and trash racks. The flow through an obstruction may be subcritical or supercritical.

### B. Hydraulic Grade Line Limits

- (1) The hydraulic grade line at any point along a channel shall not be higher than one (1) foot below the top of the channel wall.
- (2) The hydraulic grade line at any point along a channel shall not cause the hydraulic grade limits of the storm sewer system to be exceeded as stated in [Section 8.030.03](#) of these standards.

## 11. Hydraulic Jump

When flow changes from the supercritical to subcritical state, a hydraulic jump may

## Section 8 Storm Drainage Facilities

occur. A study should be made on the height and location of the jump, and for discharges less than the design discharge, to ensure adequate wall heights extend over the full ranges of discharge.

### **12. Improved Channel Junctions**

#### A. General

- (1) Consideration shall be given in the design of improved channel junctions to the geometry of the confluence of flows in order to minimize undesirable hydraulic effects due to supercritical velocities.

#### B. Confluence Design Criteria

- (1) The momentum equation can be applied to the confluence design if the below stated criteria is used.
- (2) The design water-surface elevations in the two joining channels should be approximately equal at the upstream end of the confluence.
- (3) The angle of the junction intersection can vary from 0-12 degrees.
- (4) The width of the main channel shall be expanded below the junction to maintain approximate flow depths throughout the junction
- (5) Flow depths should not exceed ninety percent (90%) of the critical depth.

### **13. Erosion Protection**

Properly designed rock blankets, minimum two (2) foot thick, shall be required at each end of the improved channel. The minimum length of the rock blanket shall be twenty five (25) feet. A rock toe wall, minimum four (4) foot deep, shall be constructed at the free end of each blanket. Alternative erosion protection products may be considered, such as articulated block mattresses, etc.

### **14. Sanitary Sewer Crossings**

The characteristics of any sanitary sewer crossing shall be given consideration in the design of the channel floor.



### **8.030.06 Culverts**

The design of culverts shall include consideration of many factors relating to requirements of hydrology, hydraulics, physical environment, imposed exterior loads, construction and maintenance.

With the design discharge and general layout requirements determined, the design requires detailed consideration of such hydraulic factors as shape and slope of approach and exit channels, allowable head at entrance (and ponding capacity, if appreciable), tailwater levels, hydraulic and energy gradelines, and erosion potential.

#### **1. Hydraulic Design**

The hydraulic design of a culvert for a specified design discharge involves (1) selection of a type and size, (2) determination of the position of hydraulic control, and (3) hydraulic computations to determine whether acceptable headwater depths and outfall conditions will result. Hydraulic computations will be carried out by standard methods based on pressure, energy, momentum and loss considerations.

#### **2. Entrances and Headwalls - Outlets and Endwalls**

Where an existing culvert is to be extended, the possibility for maintaining or improving existing capacity should be investigated. Marked improvement may be obtainable by proper entrance design. All culverts shall be designed for possible extension unless there are extenuating circumstances.

## **8.040 Bridges**

Bridges shall be designed to meet IDOT requirements.

### **8.040.01 Waterway Capacity and Backwater Effects**

Sufficient capacity will be provided to pass the runoff from the design storm determined in accordance with principles given elsewhere in this Manual.

### **8.040.02 Clearance**

The lowest point of the bridge superstructure shall have a (freeboard) clearance of two (2) feet above design water surface elevation for the 15-year frequency.

### **8.040.03 Waterway Alignment**

The bridged waterway will be aligned to result in the least obstruction to stream flow, except that for natural streams consideration will be given to future realignment and improvement of the channel.

### **8.040.04 Erosion Protection**

To preclude failure by scouring, abutment and pier footings will usually be placed either to a depth of not less than five (5) feet below and anticipated depth of scour, or on firm

rock if such is encountered at a higher elevation. Large multispan structures crossing alluvial streams may require extensive pile foundations. To protect the channel, revetment on channel sides and/or bottom should be placed as required.

### **8.050 Outlet Erosion Protection**

If outlet velocities exceed 5 fps, an appropriate erosion protection must be provided. Erosion protection may be required at outlets where velocities are less than 5 fps if soil conditions warrant.

For paved channels a cutoff wall will be required at the termini with appropriate protection. The cutoff wall shall extend a minimum depth of four (4) feet into the existing ground line.

### **8.060 Stormwater Management for Development and Redevelopment Projects**

All new developments and redevelopments in the City shall have a properly designed stormwater management systems to help prevent downstream flooding, stream bank erosion, the destruction of habitats, and contaminating water sources.

#### **8.060.01 Minimization of Increases in Runoff Volumes and Rates**

In the selection of a drainage plan for a new development or re-development; the applicant shall evaluate and implement site design features which minimize the increase in runoff volumes and rates from the site and maintain downstream water quality. The applicant's drainage plan submittal shall include evaluations which are consistent with the following hierarchy:

1. Preservation of regulatory floodplains, flood prone and wetland areas
2. Minimize impervious surfaces on the property, consistent with the needs of the project.
3. Attenuate flows by use of open vegetated swales and natural depressions and preservation of the existing natural streams, channels and drainageways.
4. The use of native, deep-rooted landscaping as an alternative to turf grass.
5. The use of open vegetated channels, filter strips, and infiltration (basins, trenches, floodplain restoration, etc.) to convey, filter and infiltrate stormwater runoff and minimize the usage of minor stormwater systems.
6. Preservation of the natural infiltration and storage characteristics of the site (e.g., disconnection of impervious cover, on-lot bio-retention facilities, rooftop detention, parking lot detention).
7. Structural measures that provide water quality and volume control (stormwater wetland, wet detention facilities, sedimentation traps, etc.).

## Section 8 Storm Drainage Facilities

8. Infiltration of runoff on-site.
9. Provide storm water retention structures.
10. Provide wet or wetland detention structures.
11. Provide dry detention structures.
12. Construct storm sewers.

### **8.060.02 Water Quality and Multiple Uses**

1. The drainage system should be designed to minimize adverse surface and groundwater quality impacts off-site and on the property itself. Detention basins shall incorporate design features to capture storm water runoff pollutants. When designers propose wet bottom and wetland type designs, all flows from the development shall be routed through the basin (i.e. low flows shall not be bypassed). When it is not practical or feasible to route all of the project's flow to the detention basin, the design of the basin shall compensate for the bypass flow. In cases where detention facilities are practical and the long-term maintenance of such facilities is provided for, detention of storm water shall be promoted through the property's drainage system to reduce the volume of storm water runoff and to reduce the quantity of runoff pollutants.
2. Green infrastructure and non-structural BMPs are recommended to control stormwater runoff for projects with less than 1.0 acre of new impervious area.
3. Developments shall meet water quality and buffer standards to the maximum extent that is practicable.
  - A. The development shall provide water quality treatment for runoff from increased impervious area to minimize impacts of post-development stormwater runoff on water quality.
  - B. The first inch of runoff from the new impervious area of development on the site shall be water quality control storage.
4. The drainage system should incorporate multiple uses where practicable. Uses considered compatible with storm water management include open space, aesthetics, aquatic habitat, recreation (boating, fishing, trails, playing fields), wetlands and water quality mitigation.

## Section 8 Storm Drainage Facilities

5. Water quality shall adhere to the following:
  - A. Illinois Environmental Protection Act – 415 ILCS 5/12, from Ch.111 1/2., par 1011 & 1012
  - B. Illinois Pollution Control Board Rules & Regulations - Title 35: Environmental Protection, Subtitle C: Water Pollution, Chapter I: Pollution Control Board, Part 302 Water Quality Standards
  - C. Illinois Pollution Control Board Rules & Regulations – Title 35: Environmental Protection, Subtitle C: Water Pollution, Chapter I: Pollution Control Board, Part 304 Effluent Standards.

### **8.060.03 Design Criteria, Standards, and Methods**

1. Release Rates

The drainage system for new developments or redevelopments shall be designed to control the peak rate of discharge from the property for the 2-year, 10-year, and 100-year, critical duration storm events to discharge rates at or below those which existed prior to development. Additionally, the discharge from a storm water detention facility shall not cause an increase in flooding or channel instability downstream when considered in aggregate with other developed properties and downstream drainage capacities. In areas where the drainage system discharges to a watershed identified as sensitive in the Watershed Plan, a greater reduction of discharge rates may be required.

  - A. Detention Basin Outlet Design

The detention basin outlet control structures shall be designed to account for observed or anticipated downstream tailwater elevations. The tailwater elevations used in the detention model shall be for the particular storm frequency being routed through the detention basin. An emergency spillway or overflow device shall be provided and set at the 100-year design high water elevation.
  - B. A calculation shall be made to determine the water elevation in the detention basin that would result from a 100-year critical duration storm event or 24-hour event (whichever produces the higher water elevation) with the outflow control structure openings blocked. The discharge rate flowing through the emergency spillway shall not exceed the 100-year pre-development flow rate. The top of bank for the detention basin shall be set at least one foot above this elevation. The lowest finished floor elevation of the adjacent structures shall be at least

## Section 8 Storm Drainage Facilities

one foot above the detention basin top of bank.

### 2. Detention Storage Requirements

The detention storage requirements can be found in [Section 8.060.03.1.A.](#)

### 3. Drainage System Design and Evaluation

The following criteria should be used in evaluating and designing the drainage system. The design will provide capacity to pass the 15-year, 20-minute storm event flow rate in the minor drainage system and an overland flow path for flows in excess of the design capacity, meeting the requirements of [Section 8.030.](#)

#### A. Positive Drainage

When practical, all developments must be provided an overland flow path that will pass the 100-year, 24 hour event flow at a stage at least one (1) foot below the lowest grade, adjacent to a structure, in the vicinity of the flow path.

#### B. Alteration of Drainage Patterns

The design of stormwater management systems shall not result in any transfer of water between watersheds unless no reasonable alternative exists as determined by the City Engineer.

#### C. Design Methodologies

TR-20, WinTR-20, or HEC-HMS producing a hydrologic model shall be used for the following:

- (1) To determine peak runoff rates for areas with a drainage area of 100 acres or greater; and,
- (2) To confirm the stormwater storage requirements for stormwater facilities that have a drainage area of 10 acres or more

The Rational method TR-55 may be used to calculate discharges for areas that drain less than 100 acres. TR-55 with a pond routing program such as TR-20 or HEC-HMS may be used to confirm stormwater storage requirements. Other methods may be used with the approval of the City Engineer.

#### D. Runoff Calculations

Runoff calculations for all offsite tributary land shall be based on either the anticipated future land conditions or existing land use conditions. Anticipated future land use conditions will be based on future land use and existing offsite storage facilities. Existing land use conditions will be based on existing land use and existing off site storage facilities.

## Section 8 Storm Drainage Facilities

### E. Rainfall

Unless a continuous simulation approach to drainage system hydrology is used, all design rainfall events shall be based on the Illinois State Water Survey's Bulletin 75. The precipitation frequency estimates, and their time distributions presented in this bulletin supersede those published in Bulletin 70, Circular 172, and Circular 173.

- (1) The first quartile point rainfall distribution shall be used for the design and analysis of detention basins and conveyance systems with critical durations less than or equal to 6 hours.
- (2) The second quartile point distribution shall be used for the design and analysis of detention basins and conveyance systems with critical durations greater than six hours and less than or equal to 12 hours.
- (3) The third quartile point rainfall distribution shall be used for the design and analysis of detention basins and conveyance systems with critical durations greater than 12 and less than or equal to 24 hours.
- (4) The fourth quartile point rainfall distribution shall be used in the design and analysis of detention basins and conveyance systems with critical durations greater than 24 hours.
- (5) The first, third, and fourth quartile distributions described by Huff are presented in Table 26 of Bulletin 75. Refer to Table 13 (for Section 8 Southwest) of Bulletin 75 for rainfall depth duration, and frequency. The NRCS Type II distribution may be used as an alternate to the Huff distributions. Adjustments for the "St. Louis Urban Effect" as given in Table 4, of Illinois State Water Survey Circular 172 is not applicable when Bulletin 75 rainfall data is used.

### F. Curve Numbers (CN)

A CN value of 80 shall be used for existing agricultural land.

### G. Antecedent Moisture

Average antecedent moisture conditions shall be assumed when calculating runoff curve numbers for use in the SCS TR-55 method.

## 4. Wet Retention Basin Design

Wet retention basins shall be designed to remove stormwater pollutants, to be safe, to be aesthetically pleasing, and as much as feasible to be available for recreation use.

### A. Wet Basin Depths

Wet basins shall be at least three feet deep, excluding near-shore banks and

## Section 8 Storm Drainage Facilities

safety ledges. If fish habitat is to be provided, the basin shall be at least eight (8) feet deep over 25-percent of the bottom area to prevent winterkill.

### B. Wet Basin Shoreline Slopes

The side slopes of wet basins at the normal pool elevation shall not be steeper than three to one (3 to 1 horizontal to vertical). It is recommended that aquatic vegetation be established around the perimeter to provide erosion protection for the shorelines. For basins in excess of five acres, rip rap shoreline protection or native wetland and wet prairie vegetation with a deep root system shall be provided to stabilize the soil.

### C. Permanent Pool Volume

The permanent pool volume in a wet basin at normal depth shall, at a minimum, be equal to the runoff volume from its watershed for the 2-year, critical duration storm event (calculated during dry weather conditions).

### D. Wet Basin Inlet and Outlet Orientation

The distance between detention inlets and outlets shall be maximized. Inlets and outlets shall be at opposite ends of the basin providing that the orientation does not create undue hardship based on topography or other natural constraints.

## 5. Dry Detention Basin Design

In addition to the other requirements of this section, dry basins shall be designed to remove storm water pollutants, to be safe, to be aesthetically pleasing and as much as feasible to be available for multiple uses. Lined low flow channels may be used in a dry basin provided provisions are made to prevent ponding.

### A. Dry Basin Drainage

Dry basins shall be designed so that 80-percent of their bottom area shall have standing water no longer than 72 hours for any runoff event less than the 100-year, critical duration storm event. Grading plans shall clearly distinguish the wet portion of the basin bottom. Underdrains directed to the outlet may be used to accomplish this requirement.

### B. Velocity Dissipation

Velocity dissipation measures shall be incorporated into dry basin designs to minimize erosion at inlets and outlets and to minimize resuspension of pollutants.

### C. Dry Basin Inlet and Outlet Orientation

Shall be the same as [Section 8.060.03.4.D](#).

## Section 8 Storm Drainage Facilities

### 6. Existing Depressional Areas

Existing depressional storage volume will be maintained, and the volume of detention storage provided to meet the requirements of this section shall be in addition to this existing storage.

### 7. Minimum Detention Outlet Size

Notches or weirs are preferred to a round orifice because this configuration better controls a range of storm events. Where a single pipe outlet orifice plate is to be used to control discharge, it shall have a minimum diameter of 12-inches for larger basins. If this minimum size permits release rates greater than those specified in this section, alternative outlet design shall be utilized which incorporate self-cleaning flow restrictors. The minimum area for the flow restrictor is 12.56 square inches (equivalent to a 4-inch diameter circular orifice). The outlet pipe and control devices shall be designed to minimize maintenance requirements and prevent tampering.

### 8. Detention in Floodplains

The placement of detention basins within the riverine floodplain (Zones A and AE) is not allowed unless approved for a specific site by the City Engineer because of questions about their reliable operation during flood events. If approval is granted, the storm water detention requirements of this section may be fulfilled by providing detention storage within flood fringe areas on the project site provided the following provisions are met.

#### A. Detention in Flood Fringe Areas

The placement of a detention basin in a flood fringe area shall require compensatory storage for 1.5 times the volume below the base flood elevation occupied by the detention basin including any berms. The release from the detention storage provided shall still be controlled consistent with the requirements of this section. The applicant shall demonstrate its operation for all stream-flow and floodplain backwater conditions. Excavations for compensatory storage along watercourses shall be opposite or adjacent to the area occupied by detention. All floodplain storage lost below the existing ten-year flood elevation shall be replaced below the existing ten-year elevation. All floodplain storage lost above the existing ten-year flood elevation shall be replaced above the existing ten-year flood elevation. All compensatory storage excavations shall be constructed to drain freely and openly to the watercourse and comply with Chapter 18.06 of the City's Code of Ordinances.

#### B. Detention in Floodways

Detention in floodways is prohibited.



## Section 8 Storm Drainage Facilities

### C. On-Stream Detention

On-Stream detention is prohibited.

### 9. Drainage into Wetlands, Streams, Lakes, Ponds, and Depressional Storage Areas

Wetlands, streams, lakes, ponds and depressional storage areas shall be protected from damaging modifications and adverse changes in runoff quality and quantity associated with land developments. In addition to the other requirements of this chapter, the following requirements shall be met for all developments whose drainage flows into wetlands, lakes, ponds or depressional storage areas:

#### A. Detention in Wetlands, Streams, Lakes, Ponds or Depressional Storage Areas

Existing wetlands, streams, ponds or depressional storage areas shall not be modified for the purpose of storm water detention unless it is demonstrated that the proposed modifications will maintain or improve its habitat and ability to perform beneficial functions. Existing storage and release rate characteristics of wetlands, streams, lakes, ponds or depressional storage areas shall be maintained and the volume of detention storage provided to meet the requirements of this section shall be in addition to this existing storage.

#### B. Drainage into, or detention within, wetlands classified as Waters of the United States (WOTUS) may be allowed, subject to obtaining regulatory permitting or written clearance from the United States Army Corp of Engineers (USACE). In addition to the other requirements of this Design Manual, the following requirements shall be met for all development whose drainage flows into the WOTUS.

- (1) The 2-year discharge rate to the WOTUS shall not exceed 0.04 cfs/acre (the 2-year detention volume must be provided upstream of the WOTUS).
- (2) The existing depressional storage of the WOTUS shall be maintained. The volume of detention storage provided to meet the discharge rate requirements shall be in addition to the existing depressional storage.
- (3) The site drainage patterns shall not be altered to substantially decrease or increase the area tributary to the WOTUS.

#### C. Buffer areas shall be required for all areas defined as WOTUS. The buffer area for all WOTUS shall extend landward from the ordinary high-water mark. The buffer area for jurisdictional or mitigated wetlands shall extend from the edge of the delineated wetland. A property may contain a buffer area that originates from WOTUS on another property. Buffer areas are divided into two types, linear buffers and water body buffers.

- (1) Linear buffers shall be designated along both sides of all channels meeting

## Section 8 Storm Drainage Facilities

the definition of WOTUS:

- a. When the channel has a watershed greater than 20 acres, the minimum buffer shall be 30 feet on each side of the channel.
  - b. Channels with an Index of Biotic Integrity (IBI) greater than 35 shall have a minimum buffer width of 100 feet on each side of the channel. (Initial IBI based on IDNR, IEPA data, or site specific assessment, whichever is most current.)
- (2) Water body buffers shall encompass all non-linear bodies of water meeting the definition of WOTUS including wetlands, lakes, and ponds.
- a. For all water bodies with a total surface area of 0.10 acre but less than one (1) acre, a minimum buffer width of 30 feet shall be established.
  - b. For all water bodies with a total surface area greater than or equal to one (1) acre but less than 2.5 acres, a minimum buffer width of 40 feet shall be established.
  - c. For all water bodies with a total surface area of 2.5 acres or greater, a minimum buffer width of 50 feet shall be established.

### D. Sediment Control

The existing wetlands, streams, lakes, ponds, or depressional storage areas shall be protected during construction by appropriate soil erosion and sediment control measures and shall not be filled.

### E. Alteration of Drainage Patterns

Site drainage patterns shall not be altered to substantially decrease or increase the existing tributary to the wetland, streams, lakes, ponds or depressional storage areas.

### F. Detention/Sedimentation

All runoff from the development shall be routed through a preliminary detention/sedimentation basin designed to capture the two-year, 24-hour event and hold it for at least 24 hours, before being discharged to the wetland, stream, lake, pond, or depressional storage area. This basin shall be constructed before property grading begins and shall be maintained throughout the construction process. In addition, the drainage hierarchy defined in [Section 8.060.01](#) should be followed to minimize runoff volumes and rates being discharged to the wetlands, streams, lakes, ponds or depressional storage areas and as further regulated in [Section 8.060.03](#) of this section.

### G. Loessal Soils

Care must be taken to avoid open flow discharges of storm water over silt (loessal) soils due to high potential for erosion.

## Section 8 Storm Drainage Facilities

### H. Sinkholes, Karst Area

The following requirements apply for new developments and redevelopments where sinkholes are determined to be present:

- (1) A storm water detention basin shall not be placed in or over a sinkhole.
- (2) Storm water detention shall not be located closer than 100 feet from the rim of a sinkhole.
- (3) The outflow from a storm water detention basin, channel, ditch or any storm water runoff generated as a result of a new development or redevelopment shall not empty into or be directed, redirected by any means into or through any sinkhole.
- (4) If, after review of the storm water drainage plan, the City Engineer may determine that more detailed information or a sinkhole evaluation is required. A sinkhole evaluation which addresses the geologic, engineering and environmental factors resulting from a new development or redevelopment shall be performed by a professional geotechnical engineer with experience and expertise in karst topography, who shall certify the results of the evaluation. This evaluation shall be the responsibility of the applicant, performed at no cost to the City. After review of this evaluation, the City Engineer may either approve or disapprove the drainage plan as submitted.
- (5) Whenever a new sinkhole appears or it becomes apparent that a sinkhole has not yet been identified, it shall be reported to the County Soil and Water Conservation District.

### 10. Street Detention and Parking Lot Detention

#### A. Street Detention

Storm water detention on streets is not allowed.

#### B. Parking Lot Detention

The maximum storm water ponding depth in any parking area shall not exceed four (4) inches for more than four (4) hours.

### 11. Underground Detention Storage

In addition to other applicable requirements of this Section, underground detention storage shall be designed to remove stormwater pollutants by collecting sediment and floatable debris, to be safe, and to meet the following requirements:

#### A. Underground Detention Chambers

Adequate access shall be provided to all chambers for inspection, maintenance, and removal of accumulated sediment and debris.

## Section 8 Storm Drainage Facilities

### B. Positive Drainage

Underground facilities shall be sloped to provide positive drainage via gravity to the outlet.

### C. Storage Volume

The required detention volume shall be provided in the storage structure, storage pipe, or reservoir stone. Storage volume in voids in the bedding material will not be considered part of the detention volume. The volume of stone void space in the reservoir stone layer of an aggregate basin or an infiltration basin may provide detention storage volume and shall be assumed to be no greater than 40% void space.

### D. Location

Underground detention facilities shall be located far enough from property lines and buildings to allow sufficient space for installation, maintenance, and future repairs as well as to prevent building foundation damage if the storage basin fails or is not watertight. A minimum separation of ten (10) feet from adjacent property lines and buildings is required. Exceptions may be allowed when the building foundation is designed to account for the proximity of the underground basin.

### E. Design

Underground detention and infiltration facilities shall be designed, signed, and sealed by an Illinois Licensed Professional Engineer, and structural components shall be designed, signed and sealed by Illinois Licensed Structural Engineer.

## 12. Infiltration Practices

Infiltration practices including basins, trenches, and porous pavement may be used as detention facilities subject to the following:

- A. The facility must be designed to dewater within 72 hours following the end of the 100-year critical duration storm event.
- B. The underlying soils must have an infiltration rate of at least 0.5 inches per hour as determined by an engineer and be located in hydrologic soil groups "A" or "B" as designated by the U.S.D.A. Natural Resources Conservation Service.
- C. Pretreatment facilities must be provided to prevent obstruction.
- D. The facility must be at least 200 feet away from any water supply wells or maximum setback zone if established.

## Section 8 Storm Drainage Facilities

- E. Runoff from the areas that have water quality concerns or are subject to frequent winter deicing must not be routed to the infiltration facility.
- F. The bottom of the infiltration facility must be at least four (4) feet above the seasonal high groundwater.

### 13. Vegetated Filter Strips and Swales

To effectively filter storm water pollutants and promote infiltration of runoff, sites should be designed to maximize the use of vegetated filter strips and swales. Whenever practicable, runoff from impervious surfaces should be directed onto filter strips and swales comprised of native grasses and forbs before being routed to a storm sewer or detention basin.

### 14. Safety Considerations

The drainage system components, especially all detention basins, shall be designed to protect the safety of any children or adults coming into contact with the system during runoff events.

#### A. Side Slopes

The side slopes of all detention basins at 100-year, critical duration storm event capacity shall be as level as practicable to prevent accidental falls into the basin and for stability and ease of maintenance. Side slopes of detention basins and opens channels shall not be steeper than three (3) horizontal to one (1) vertical.

#### B. Safety Ledge

All wet detention basins shall have a level safety ledge at least four (4) feet in width, 2.5 to three (3) feet below the normal water depth or it must be protected by an enclosed fence that is at least 48 inches in height.

#### C. Velocity

Velocities throughout the surface drainage system shall be controlled to safe levels taking into consideration rates and depths of flow.

#### D. Overflow Structures

See [Section 8.060.03.1](#).

### 15. Maintenance Considerations

The storm water drainage system shall be designed to minimize and facilitate maintenance. Turfed side slopes shall be designed to allow mowing equipment to easily negotiate them. Wet basins shall be provided with alternate outflows which can be used to completely drain the pool for sediment removal. Pumping may be

## Section 8 Storm Drainage Facilities

considered if drainage by gravity is not feasible. Pre-sedimentation basins shall be included, where feasible, for localizing sediment deposition and removal. Site access for heavy equipment shall be provided.

### 8.060.04 Accommodating Flows from Upstream Tributary Areas

Storm water runoff from areas tributary to the property shall be considered in the design of the property's drainage system. Whenever practicable, flows from upstream areas that are not to be detained should be routed around the basin being provided for the site being developed. Off-site flow may be diverted around a proposed detention facility provided that the other applicable standards regarding regulatory floodplain or flood-prone areas are met. Peak runoff at the point where off-site and detention outlet flows shall be analyzed to verify the peak runoff is not increased from that of the pre-developed condition.

1. Upstream Areas Not Meeting Section Requirements:
  - A. When there are areas not meeting the storage and release rates of this chapter, tributary to the applicant's property, regionalized detention on the applicant's property may be explored by the applicant or the City. When it is deemed beneficial by the City or the applicant to explore such a design, the following steps shall be followed:
    - (1) The applicant shall compute the storage volume needed for their property using the release rates of [Section 8.060.03](#) and the procedures described in [Section 8.060.02](#).
    - (2) Areas tributary to the applicant's property, not meeting the storage and release rate requirements of this section, shall be identified
    - (3) Using the areas determined above plus the applicant's property area, the total storage needed for the combined properties shall be computed.
  - B. Allowable release rates shall be computed using the combined property areas. Storage shall be computed as described in [Section 8.060.03](#). If tributary areas are not developed, a reasonable fully developed land cover, based on local zoning, shall be assumed for the purposes of computing storage.
  - C. Once the necessary combined storage is computed, the City may choose to pay for over-sizing the applicant's detention basin to accommodate the regional flows. If regional storage is selected by the City, then the design produced in [Section 8.060.02](#) shall be implemented. If regional storage is rejected by the City, the applicant shall bypass all tributary area flows around the applicant's basin whenever practicable.

## Section 8 Storm Drainage Facilities

### 2. Upstream Areas Meeting Requirements

When there are areas which meet the storage and release requirements of this chapter, tributary to the applicant's property, the upstream flows shall be bypassed around the applicant's detention basin if this is the only practicable alternative. Storage needed for the applicants' property shall be computed as described in Section 8.060.04.1. However, if the City decides to route tributary area flows through an applicant's basin, the final design stormwater releases shall be based on the combined total of the applicant's property plus tributary areas. It must be shown that at no time will the release rate from the combined property exceed the allowable release rate for the applicant's property alone.

#### **8.060.05 Early Completion of Detention Facilities**

Where detention, retention, or depressional storage areas are to be used as part of the drainage system for a property, they shall be constructed as the first element of the initial earthwork program. Any eroded sediment captured in these facilities shall be removed by the applicant on a regular basis and before project completion in order to maintain the design volume of the facilities.

### **8.070 Soil Erosion and Sediment Control**

The City of Collinsville requires that erosion and sedimentation caused by development activities, including clearing, grading, stripping, excavating, and filling of land be controlled to prevent damage to property, protect the traveling public, protect drainage systems and waterways, and promote the health of desirable aquatic life. Measures taken to control soil erosion and off-site sediment runoff shall be adequate to assure that sediment is not transported from the site by a storm event of two (2) year, 24-hour frequency or less. The following principles shall apply to all new development or redevelopment activities within the City and to the preparation of the submissions required in [Section 8.070.02](#) of this section.

#### **8.070.01 General**

1. New development or redevelopment shall be related to the topography and soils of the site to create the least potential for erosion. Areas of steep slopes greater than 33-percent where high cuts and fills may be required are to be avoided whenever possible, and natural contours should be followed as closely as possible.
2. Natural vegetation shall be retained and protected wherever possible. Areas immediately adjacent to natural watercourses, lakes, ponds, sinkholes, and wetlands are to be left undisturbed wherever possible. Temporary crossings of watercourses, when permitted, must include appropriate stabilization measures.
  - A. Where stream construction crossings are necessary, temporary crossings shall be constructed of non-erosive material.

## Section 8 Storm Drainage Facilities

- B. The time and area of disturbance of a stream shall be kept to a minimum. The stream, including bed and banks, shall be restabilized within 48 hours after channel disturbance is completed or interrupted.
3. Stormwater conveyance channels, including ditches, swales, and diversions, and the outlet of all channels and pipes shall be designed and constructed to withstand the expected flow velocity from the 10-year frequency storm without erosion. All constructed or modified channels shall be stabilized within 48 hours.
4. Special precautions shall be taken to prevent damages resultant from any necessary development activity within or adjacent to any stream, lake, pond, sinkhole, or wetland. Preventative measures shall reflect the sensitivity of these areas to erosion and sedimentation.
  - A. At points where concentrated flow leaves a development site, energy dissipation devices shall be placed at discharge locations and along the length of any outfall channel as necessary to provide a nonerosive velocity of flow from the structure to the watercourse so that the natural physical and biological characteristics and functions are maintained and protected.
  - B. Areas of embankments having slopes greater than or equal to 3H:1V shall be stabilized with staked-in-place sod, mat, or blanket in combination with seeding.
5. Water quality shall adhere to:
  - A. Illinois Environmental Protection Act - 415 ILCS 5/12, from Ch. 111 ½., par 1012;
  - B. Illinois Pollution Control Board Rules & Regulations - Title 35: Environmental Protection, Subtitle C: Water Pollution, Chapter I: Pollution Control Board, Part 302 Water Quality Standards; and
  - C. Illinois Pollution Control Board Rules & Regulations - Title 35: Environmental Protection, Subtitle C: Water Pollution, Chapter I: Pollution Control Board, Part 304 Effluent Standards.
6. In the design of erosion control facilities and practices, aesthetics and the requirements of continuing maintenance must be considered.
7. Provisions shall be made to accommodate the increased run-off caused by changing soil and surface conditions during and after development. Drainage ways should be designed so that their final gradients and the resultant velocities and rates of discharge will not create additional erosion on-site or downstream.



## Section 8 Storm Drainage Facilities

8. Disturbed areas shall be stabilized with temporary or permanent measures within seven (7) calendar days following the end of active hydrologic disturbance, or disturbance. Permanent vegetation and structures shall be installed and functional as soon as practical during development.
9. Those areas being converted from agricultural purposes to other land uses shall be vegetated with an appropriate protective cover prior to development. Appropriate temporary or permanent stabilization measures shall include seeding, mulching, sodding, and/or non-vegetative measures.
10. All waste generated as a result of site development activity shall be properly disposed of and shall be prevented from being carried off the site by either wind or water.
11. All construction sites shall provide measures to prevent sediment from being tracked onto public or private roadways. The applicant shall be responsible for cleaning any mud or sediment from roadways daily.
12. All temporary erosion and sediment control practices shall be maintained to function as intended until the contributing drainage area has been permanently stabilized at which time they shall be removed.

### **8.070.02 Erosion and Sediment Control Plan Submittal Requirements**

Each applicant shall submit information depending on development size (see Chapter 18.04 of the Collinsville Municipal Code and [Section 8.070.03.2](#)), as regulated to ensure that the provisions of this Section are met.

### **8.070.03 Design and Operation Standards and Requirements**

1. The preparation of soil erosion and sediment control plans and the design criteria, standards, and methods shall be prepared in accordance with the requirements of this Section and the standards and specifications contained in the "Illinois Urban Manual" prepared for the Illinois Environmental Protection Agency by the USDA Natural Resources Conservation Service, which standards and methods are hereby incorporated into this Section by reference. In the event of conflict between the provisions of said manuals and of this Section, this Section shall govern.
2. Erosion and sediment control design requirements  
New developments or redevelopments shall comply with Chapter 18.04 of the Collinsville Municipal Code and meet the following:

## Section 8 Storm Drainage Facilities

- A. Control measures shall be constructed to control runoff from the property to such an extent possible that sediment is retained on-site.
- B. Temporary on-site control measures required shall be constructed and functional prior to initiating clearing, grading, stripping, excavating or fill activities on the site.
- C. Disturbed areas shall be stabilized with permanent measures with seven (7) calendar days following the end of active disturbance, or re-disturbance consistent with the following criteria:
  - (1) Appropriate permanent stabilization measures shall include seeding, mulching, sodding, or with non-vegetative measures as a last resort.
  - (2) Areas having slopes greater than 33-percent shall be stabilized with sod, mat, or blanket in combination with seeding or equivalent.
- D. All temporary or permanent erosion and sediment control practices must be maintained and repaired as needed to ensure effective performance of their function. Repair, replace, or maintain erosion and sediment control structures after a singular or cumulative rainfall event(s) of 0.5 inches or more over a 24-hour period. Make adjustments to the sedimentation and erosion control plans and methods, as needed, to accomplish the intended purpose.
- E. Site Development requirements  
On-site sediment control measures, as specified by the following criteria, shall be constructed as specified in the referenced handbooks, and functional prior to initiating clearing, grading, stripping, excavating or fill activities on site.
  - (1) For new developments or redevelopments less than one (1) acre, or for a tract of land where a single family is being erected and less than 10,000 square feet of impervious surface is being developed, filter barriers (including filter fences or equivalent control measures) shall be constructed to control all on-site runoff. Vegetated filter strips, with a minimum width of 25 feet, may be used as an alternative only where runoff in sheet flow is expected.
  - (2) For new developments or redevelopments that are at least one (1) acre but less than five (5) acres, a sediment trap designed in accordance with the Illinois Urban Manual or equivalent control measures shall be constructed at the down slope point of the disturbed area.
  - (3) For new developments or redevelopments that are five (5) acres or greater, a sediment basin or equivalent control measure shall be constructed at the

## Section 8 Storm Drainage Facilities

down slope point of the disturbed area.

- (4) Sediment basins shall have both a permanent pool (dead storage) and additional volume (live storage) with each volume equal to the runoff amount of a 2-year, 24-hour event over the onsite hydrologically disturbed tributary drainage area to the sediment basin. The available sediment volume below normal water level, in addition to the dead storage volume shall be sized to store the estimated sediment load generated from the site over the duration of the construction period. For construction periods exceeding one (1) year, the 1-year sediment load and a sediment removal schedule may be submitted. If the detention basin for the proposed development condition of the site is used for the sediment basin, the above volume requirements will be explicitly met. Until the site is finally stabilized, the basin permanent pool of water shall meet the above volume requirements and have a filtered perforated riser protecting the outflow pipe.
  - (5) Sediment shall not be deposited into sinkholes. The alteration of sinkholes by filling, grading, or excavating is prohibited, including the area within 25 feet of the rim.
  - (6) To the extent possible or as otherwise regulated in this section all desirable trees eight (8) inches in diameter and larger shall be protected for their present and future value for erosion protection and other environmental benefits. Trees that have been selected for preservation shall be marked prior to the beginning of any clearing, grading, stripping, excavation, or filling of the site. The perimeter of the drip line of each tree which is to be preserved shall be established and marked with temporary fence or silt fence to designate the area to be undisturbed adjacent to the tree.
- F. Storm water conveyance channels, including ditches, swales, and diversions, and the outlets of all channels and pipes shall be designed and constructed as regulated in this manual. All constructed or modified channels shall be stabilized within 48 hours, consistent with the standards as required in the Illinois Urban Manual.
- G. Land disturbance activities in stream channels shall be avoided, where possible, or as regulated in this manual and Chapter 18.04 of the Collinsville Municipal Code. If disturbance activities are unavoidable, the following requirements shall be met.
- (1) Construction vehicles shall be kept out of the stream channel to the maximum extent practicable. Where construction crossings are necessary, temporary crossings shall be constructed of non-erosive material, such as riprap, gravel, or other approved material.

## Section 8 Storm Drainage Facilities

- (2) The time and area of disturbance of stream channels shall be kept to a minimum. The stream channel, including bed and banks, shall be stabilized within 48 hours after channel disturbance is completed, interrupted, or stopped.
- H. Storm sewer inlets and culverts shall be protected by sediment control barriers, inlet filters or traps meeting accepted design standards and specifications.
- I. Soil storage piles containing more than ten (10) cubic yards of material shall not be located with a down slope drainage length of less than 25 feet to a roadway, drainage channel, or sinkhole. Filter barriers, including filter fence, or equivalent shall be installed immediately on the down slope side of the piles.
- J. If dewatering devices are used, discharge locations shall be protected from erosion. All pumped discharges shall be routed through appropriately designed sediment traps or basins, or equivalent and shall not be deposited into a sinkhole.
- K. Each site shall have graveled (or equivalent) entrance roads, access, drives, and parking areas of sufficient length and width to prevent sediment from being tracked onto public or private roadways. Any sediment reaching a public or private road shall be removed by shoveling or street cleaning (not flushing) before the end of each workday and transported to a controlled sediment disposal area.

### **8.070.04 Maintenance of Control Measures**

All soil erosion and sediment control measures necessary to meet the requirements of this Section shall be maintained periodically by the applicant or subsequent landowner during the period of land disturbance and development of the site in a satisfactory manner to ensure adequate performance.

1. Control of Construction Site Wastes  
All waste materials generated during construction activities must be properly disposed. Examples of construction site waste may consist of, but not limited to, all building materials, raised structure debris, concrete (including concrete truck wash), asphalt, brick, excess soil, rebar, erosion and sediment control materials, cleared vegetation, chemicals, temporary bathroom facilities, and all other construction site wastes.
2. Construction Site Stormwater Pollution Prevention Plan  
Activities that are applicable to this Section must provide a Stormwater Pollution Prevention Plan (SWPPP) for the construction site.

## Section 8 Storm Drainage Facilities

- A. The SWPPP may be a full-sized plan sheet with necessary notes for requirements or may be a narrative explaining construction site operating procedures to minimize or eliminate storm water pollution as a result of construction activities.
- B. The items covered in an approvable SWPPP are dependent on the activities and the materials required on site to complete the project. Therefore, the detail of the Plan may be more or less depending on site activities planned. The SWPPP shall include the items required by NPDES Permit No. ILR10. Standard items included in the SWPPP are, but not limited to, the items listed in [Section 1.050.02](#).
- C. Should construction site activities/materials be changed during construction, the SWPPP must reflect the changes. Therefore, the plan must be kept on-site at all times and be altered as necessary with the approval of the Inspector. Should major changes be warranted, a revised plan must be submitted for review and approval.

### 8.080 Long Term Maintenance Responsibility

#### 8.080.01 Long Term Maintenance Responsibility

Maintenance of storm water drainage, and erosion and sediment control facilities located on private property shall be the responsibility of the owner of the property. Before an appropriate permit is obtained from the City the applicant shall execute a maintenance agreement with the City guaranteeing that the applicant and all future owners of the property will maintain its storm water drainage and erosion and sediment control system and shall provide for access to the system for inspection by authorized City personnel. The maintenance agreement shall also stipulate that if the appropriate City personnel notify the property owner in writing of maintenance problems which require correction, the property owner shall begin such corrections within 24 hours and shall not extend beyond seven (7) calendar days of such notification. If the corrections are not made within this time period, the City may have the necessary work completed and assess the cost to the property owner. The City has the option of requiring a bond to be filed by the property owner for maintenance of the storm water drainage and erosion and sediment control system.

1. The owner shall maintain all storm water management facilities in good working order in accordance with the approved O&M Plan.
2. The owner shall convey to the City easements to assure access for inspections and maintenance, if required.

## Section 8 Storm Drainage Facilities

3. The owner shall keep on file with the City the name, address, and telephone number of the person or company responsible for maintenance activities; in the event of a change, new information will be submitted to the City within ten (10) days of the change.
4. Enumerate permanent stormwater management facilities as permanent real estate appurtenances and record as deed restrictions or easements that run with the land.
5. The record owner of the development site shall sign and record an Operation and Maintenance (O&M) Agreement covering all storm water management facilities, including riparian buffers and riparian forest buffers, which are to be privately owned. The O&M Plan and Agreement shall be recorded as a restrictive covenant that runs with the land.
6. The owner of a development shall convey ownership and maintenance responsibilities of common areas of the development related to O&M of the storm water management system to the association established by the restrictive covenant agreement when at least 50-percent of the lots in the development have been conveyed to lot owners other than the developer. The stormwater management system shall be in substantial compliance with the terms of the NPDES permit at the time of transfer.
7. Bodies of water, channels, and natural streams located on privately owned property outside of recorded drainage easements or common areas shall be maintained by the property owner.

### **8.080.02 Inspections and Testing**

The City shall make inspections and perform tests as hereinafter required and shall either approve that portion of the work completed or shall notify the permittee wherein the work fails to comply with the storm drain, storm water drainage, or erosion and sedimentation control plan as approved. Plans for grading stripping, excavating, and filling work bearing the stamp of approval of the City Engineer shall be maintained at the site during progress of the work.

1. Storm water drainage and erosion and sedimentation control inspections.  
In order to obtain inspections and to ensure compliance with this Section, the permittee shall notify the City Engineer within two (2) working days of the completion of the construction stages specified below:
  - A. Upon completion of installation of storm water drainage and erosion and sediment control measures (including perimeter controls and diversions), prior to proceeding with any other earth disturbance or grading.

## Section 8 Storm Drainage Facilities

- B. After stripping and clearing.
  - C. After rough grading.
  - D. After final grading.
  - E. After seeding and landscaping deadlines, and
  - F. After final stabilization and landscaping, prior to removal of sediment controls.
2. If stripping, clearing, grading, and/or landscaping are to be done in phases or areas, the permittee shall give notice and request inspection at the completion of each of the above work stages in each phase or area. If an inspection is not made and the permittee is not notified of the results within five working days after notice is received by the City from the permittee, the permittee may continue work at his/her own risk, without presuming acceptance by the City. Notification of the results of the inspection shall be given in writing at the site.
3. Storm drain and structure inspections and testing  
All projects shall be inspected and tested upon completion of installation in the presence of City staff. The City Engineer will designate the locations of test and extent of the system to be tested, and extent of recording test results. Equipment for performing tests and making measurements shall be furnished by the contractor. Sections of storm sewer which fail to pass the tests shall have defects located and repaired or replaced and be retested until with the specified allowance.
- A. Cleaning  
Prior to acceptance, all the storm sewer and storm sewer appurtenances shall be cleaned and operational to the satisfaction of the City Engineer.
  - B. Visual Test  
The City requires that storm sewer lines be inspected visually to verify accuracy of alignment and freedom from debris and obstructions. The full diameter of the pipe for straight alignments shall be visible when viewed between consecutive structures. The method of test shall be closed circuit television.
  - C. Deflection Testing  
A mandrel test is required by the City from structure to structure for all storm sewer lines installed. Deflection limits for flexible pipe materials shall not exceed the manufacturer's recommended deflection limit or a maximum of 5.0% of the internal diameter of the pipe, whichever is more stringent.

## Section 8 Storm Drainage Facilities

Where deflection is found in excess of allowable testing limits, the contractor shall excavate to the point of excess deflection and carefully compact around the point where excess deflection was found. The line shall then be retested for deflection. However, should after the initial testing the deflected pipe fail to return to the original size (inside diameter), the line shall be replaced.

### D. Leakage Test

After a structure to structure reach of pipe has been backfilled to final grade and prepared for testing, the pipe shall be air tested in accordance with *“Standard Specifications for Water and Sewer Construction in Illinois”*

4. The owner/developer and on-site personnel shall be notified in writing when violations are observed. Written notification shall describe the nature of the violation and the required corrective action and date.
5. The owner/developer shall have the site inspected bi-weekly and after each rainfall event of one half (1/2) inches or more over a 24-hour period. Bi-weekly and rainfall inspection reports shall be submitted to the City for all development permits. Excepting permits involving the development of one single family dwelling the bi-weekly reports must be certified by a registered professional engineer or certified storm water inspector, describing the current status of construction for proposed drainage and detention systems, including whether drainage construction and erosion control has been installed in accordance with the construction plans. The report shall define whether maintenance has been provided as needed for the erosion.

### **8.080.03 Specialized Precautions**

If at any stage of the grading of any development site the City Engineer determines by inspection that the nature of the site is such that further work authorized by an existing permit is likely to imperil any property, public way, stream, lake, wetland, or drainage structure, the City Engineer may require, as a condition of allowing the work to be done, that such reasonable special precautions be taken as is considered advisable to avoid the likelihood of such peril.

“Special Precautions” may include, but shall not be limited to, a more level exposed slope, construction of additional drainage facilities, berms, terracing, compaction, or cribbing, installation of plant materials for erosion control, and recommendations of a soil scientist and/or engineering geologist, which may outline requirements for further work.

Where it appears that storm damage may occur due to incomplete grading at the site, work may be stopped, and the permittee required to install temporary structures or



## Section 8 Storm Drainage Facilities

take such measures as may be required to protect adjoining property or the public safety. On large development or where unusual site conditions prevail, the City may specify the start and end dates of grading operations or may require that the operations be conducted in specific stages so as to ensure completion of protective measures or devices prior to the advent of seasonal rains.

### **8.080.04 Amendments of Plans**

Major amendments to storm water drainage and detention or erosion and sediment control plans shall be submitted to the City Engineer and shall be processed and approved or disapproved in the same manner as the original plans. Field modification of a minor nature may be authorized by the City Engineer by written authorization to the permittee.

### **8.080.05 Final Certification**

Prior to final approval by the City, a registered professional engineer shall certify that the detention basin has been constructed in accordance with the construction plans and the proposed volume has been provided. An "as-built" survey of the detention basin, prepared by a licensed surveyor, shall be included with the certification for approval.

**Exhibit 8-A**

Check List for Review of Stormwater Detention

The following check list is intended to provide guidance in review detention designs. It is not intended to supersede any criteria in the latest version of the City's "Infrastructure Design Manual".

Project No \_\_\_\_\_

Project Name: \_\_\_\_\_

Location: \_\_\_\_\_

- \_\_\_\_\_ 1. Contact for downstream problems.
- \_\_\_\_\_ 2. Detention required if differential runoff, per **8.060.01.1.A**, is greater than 2 cfs, or if required by the City due to flooding problems.
- \_\_\_\_\_ 3. For building and parking lot additions, detention is required if there is existing detention. Check existing calculations to see if addition is covered.
- \_\_\_\_\_ 4. No reduction in outfall pipe size permitted because of detention.
- \_\_\_\_\_ 5. Basin located at or near lowest point of site such that on-site runoff will be directed to basin.
- \_\_\_\_\_ 6. Offsite flows bypassed around basin.
- \_\_\_\_\_ 7. Underground basin had adequate access for maintenance.
- \_\_\_\_\_ 8. Provide means of visual inspection of both sides of low flow device from ground surface for underground basin.
- \_\_\_\_\_ 9. Underground basin has volume and spillway capacity to pass/contain 100-year, 24-hour event with low and intermediate flow openings fully blocked and water ponded to sill of overflow structure, unless directed otherwise by the City. It is further recommended that the control structure have at least 2 openings, one above the other.
- \_\_\_\_\_ 10. Check flow capacity of downstream pipe with inlet control nomographs found in Hydraulic Design of Highway Culverts, U.S. Department of Transportation publication.

## Section 8 Storm Drainage Facilities

- \_\_\_\_\_ 11. Check inlet control constants as entered in the analysis to match the Hydraulic Design of Highway Culverts per U.S. Department of Transportation.
- \_\_\_\_\_ 12. Aluminized corrugated metal pipe (CMP) allowed for commercial projects only, gauge specified.
- \_\_\_\_\_ 13. No underground basins allowed for residential projects, except by cooperation and a technical lack of other options.
- \_\_\_\_\_ 14. TR-55 or similar SCS method used for hydrology; Type II rainfall distribution. 100 foot maximum distance for sheet flow component of time of concentration. Also be sure to use proper n-value from TR-55 [Table 8.1](#) for sheet flow component.
- \_\_\_\_\_ 15. 2-year and 100-year, 24-hour rainfall amounts of 3.23" and 7.31", respectively.
- \_\_\_\_\_ 16. Legible Detention Basin Area maps showing total acres tributary to each point of interest, flow paths used in time of concentration calculations with each flow segment indicated and labeled, and CN values for existing and proposed conditions, 24" X 36" exhibits are preferred.
- \_\_\_\_\_ 17. CNs for vegetated areas located within the post-construction disturbance limits shall be assumed to be hydrologic soil group D during modeling of post-construction conditions, unless soil amendments are used.
- \_\_\_\_\_ 18. Elevations vs. Discharge table, including modeling data.
- \_\_\_\_\_ 19. Elevation vs. Storage table.
- \_\_\_\_\_ 20. Hydraulic gradeline calculations for incoming and outgoing pipes.
- \_\_\_\_\_ 21. Provide a copy of the NRCS web soil survey map and label site.
- \_\_\_\_\_ 22. Geotechnical report may be required for embankment.
- \_\_\_\_\_ 23. Structural calculations may be required for control structure.
- \_\_\_\_\_ 24. Details of control structure showing reinforcement.
- \_\_\_\_\_ 25. Minimum of 3 cross sections through basin for as-built calculations tied to a baseline or known point or to Property Line.
- \_\_\_\_\_ 26. Incoming pipes should discharge at the toe of the slope in dry basins.

## Section 8 Storm Drainage Facilities

- \_\_\_\_\_ 27. Pervious pilot swale provided from incoming pipes to control structure.
- \_\_\_\_\_ 28. Pervious pilot swale is a minimum of 6 inch deep.
- \_\_\_\_\_ 29. Details for permanent erosion control for earthen swales with slopes greater than 3%.
- \_\_\_\_\_ 30. Minimum longitudinal slope of pilot swale is 2.0%, slope called out on plan.
- \_\_\_\_\_ 31. Bottom of basin is sloped a minimum of 2% laterally towards earthen swale and called out on plan.
- \_\_\_\_\_ 32. Rock blanket provided along outside of curved sale downstream of incoming pipe to prevent erosion.
- \_\_\_\_\_ 33. Concrete headwall provided around protruding low flow pipe.
- \_\_\_\_\_ 34. Trash rack provided for low flow openings less than 6" wide.
- \_\_\_\_\_ 35. No railroad tie walls within ponding area of basin.
- \_\_\_\_\_ 36. Maximum fluctuation above permanent pool is 6'.
- \_\_\_\_\_ 37. Maximum side slopes are 3:1 without fencing.
- \_\_\_\_\_ 38. Dry basins and the fluctuating areas of lakes are to be appropriately vegetated to the maximum high water elevation, call out on plan. Sod and mowing may be approved above that level (required, if not ripped).
- \_\_\_\_\_ 39. Control structures are to be reinforced concrete; no brick allowed; wall thickness is at least 8" with one row of steel or 10" with two rows of steel.
- \_\_\_\_\_ 40. In basins with walls, provide access ramp.
- \_\_\_\_\_ 41. No wetland mitigation in detention basin.
- \_\_\_\_\_ 42. Maximum depth of water in a dry basin is 8' exceptions on a case-by-case basis.
- \_\_\_\_\_ 43. Maximum depth of water in a parking lot is 4", 8" for truck parking lots.
- \_\_\_\_\_ 44. Maximum ponding elevation calculated with low and intermediate flow openings fully blocked and water ponded to sill of overflow structure, unless directed otherwise by the

## Section 8 Storm Drainage Facilities

City.

- \_\_\_\_\_ 45. Limits of maximum ponding are 30' horizontally and 2' vertically from a building; 10' horizontally and 1' vertically for parking lot detention.
- \_\_\_\_\_ 46. Freeboard from top of berm to maximum ponding elevation is at least 1'.
- \_\_\_\_\_ 47. Basin is located in common ground or easement dedicated to subdivision trustees.
- \_\_\_\_\_ 48. Owners of the basin execute a City Maintenance Agreement.
- \_\_\_\_\_ 49. Four foot high fence required if side slopes are steeper than 3:1, including walls.
- \_\_\_\_\_ 50. Hydraulic calculations showing 100-year flow is conveyed to basin; calculations at ditch sections, sills of structures et above 100-yr elevation.
- \_\_\_\_\_ 51. Smallest low flow opening is 1.5" diameter. However, special trashrack or opening protection may be required.
- \_\_\_\_\_ 52. Detention cannot cross watershed boundary. Watershed and sub-watershed tributary areas to each point of interest shall remain unchanged when comparing existing and proposed conditions.
- \_\_\_\_\_ 53. Discharge pipe into wet basin shall be a minimum of 3' above bottom, or flowline of pipe shall be no higher than the normal pool elevation.
- \_\_\_\_\_ 54. The report shall have a Table of Contents which is sealed by a Illinois Professional Engineer.
- \_\_\_\_\_ 55. The report shall contain a written summary describing the existing and proposed conditions and the design/modeling approach used to manage stormwater. All calculations shall be included. Hard copies shall be bound.
- \_\_\_\_\_ 56. The starting hydraulic grade line for all incoming pipes shall be the 100-year 24-hour blocked low flow water surface elevation, or an elevation approved by the City.
- \_\_\_\_\_ 57. For some channel and wetlands work, a 404 and/or 401 permit may be required from the Corps and IDNR, respectively.

Section 8 Storm Drainage Facilities

P FACTOR FOR RUNOFF						
% IMPERVIOUS	DURATION OF RAIN IN MINUTES					
	15	20	30	60	90	120
0	0.3	0.35	0.41	0.51	0.56	0.6
5	0.32	0.37	0.43	0.53	0.58	0.62
10	0.34	0.39	0.46	0.56	0.6	0.64
15	0.36	0.41	0.48	0.58	0.62	0.66
20	0.38	0.44	0.5	0.6	0.64	0.67
25	0.4	0.46	0.52	0.62	0.66	0.69
30	0.42	0.48	0.54	0.64	0.68	0.71
35	0.44	0.5	0.57	0.66	0.7	0.73
40	0.46	0.52	0.59	0.68	0.72	0.74
45	0.48	0.54	0.61	0.71	0.74	0.76
50	0.5	0.56	0.63	0.73	0.75	0.78
55	0.52	0.58	0.65	0.75	0.77	0.8
60	0.54	0.6	0.68	0.77	0.79	0.81
65	0.56	0.63	0.7	0.79	0.81	0.83
70	0.58	0.65	0.72	0.81	0.83	0.85
75	0.6	0.67	0.74	0.84	0.85	0.87
80	0.62	0.69	0.76	0.86	0.87	0.88
85	0.64	0.71	0.79	0.88	0.89	0.9
90	0.66	0.73	0.81	0.9	0.91	0.92
95	0.68	0.75	0.83	0.92	0.93	0.94
100	0.7	0.77	0.85	0.94	0.95	0.95

VALUES FOR P FOR 0% AND 100% ARE THOSE USED FOR ST. LOUIS MODIFIED 9-1939  
 RAINFALL INTENSITY OF 1 INCH PER HOUR ON 1 ACRE = 1.008 CU. FT. PER SECOND ON 1 ACRE  
 = 1 CU. FT. PER SECOND ON 1 ACRE (APPROXIMATELY)

$P \times I = Q$  = RUNOFF IN CU. FT. PER SEC. PER ACRE FOR GIVEN % IMPERVIOUSNESS OF  
 CONTRIBUTING AREA DURING A RAINFALL OF GIVEN INTENSITY  
 CORRESPONDING TO THE GIVEN DURATION AND A SELECTED FREQUENCY.

I = INTENSITY OF RAINFALL IN INCHES PER HOUR FOR GIVEN DURATION AND  
 GIVEN FREQUENCY.

$\frac{\text{RUNOFF}}{\text{RAINFALL}} = P$  = RATIO OF RUNOFF CONTRUBUTED BY AN AREA OF GIVEN %  
 IMPERVIOUSNESS FOR A GIVEN DURATION PERIOD TO THE RAINFALL OF  
 A GIVEN INTENSITY CORRESPONDING TO THE SAME DURATION PERIOD  
 AND A SELECTED FREQUENCY

**P (RUNOFF FACTORS) FOR  
 VARIOUS IMPERVIOUS CONDITIONS**

Runoff Factors

**Table 8.1**

Section 8 Storm Drainage Facilities

P.I. FACTOR IN CUBIC FEET PER SECOND PER ACRE														
DURATION OF RAIN IN MINUTES	% IMPERVIOUS	10-YEAR RAINFALL FREQUENCY					15-YEAR RAINFALL FREQUENCY							
		15	20	30	60	90	120	15	20	30	60	90	120	
	0	1.70	1.75	1.60	1.26	1.13	0.92	1.92	1.97	1.80	1.42	1.35	1.03	
	5	1.82	1.85	1.68	1.31	1.17	0.95	2.05	2.09	1.89	1.48	1.40	1.07	
	10	1.93	1.95	1.79	1.39	1.21	0.98	2.18	2.20	2.02	1.56	1.45	1.10	
	15	2.04	2.05	1.87	1.44	1.25	1.01	2.30	2.31	2.11	1.62	1.49	1.14	
	20	2.16	2.20	1.95	1.49	1.29	1.03	2.43	2.48	2.20	1.67	1.54	1.15	
	25	2.27	2.30	2.03	1.54	1.33	1.06	2.56	2.59	2.29	1.73	1.59	1.19	
	30	2.39	2.40	2.11	1.59	1.37	1.09	2.69	2.71	2.38	1.79	1.64	1.22	
	35	2.50	2.51	2.22	1.64	1.41	1.12	2.82	2.82	2.51	1.84	1.69	1.26	
	40	2.61	2.61	2.30	1.69	1.45	1.13	2.94	2.93	2.60	1.90	1.74	1.27	
	45	2.73	2.71	2.38	1.76	1.49	1.16	3.07	3.05	2.68	1.98	1.78	1.31	
	50	2.84	2.81	2.46	1.81	1.51	1.19	3.20	3.16	2.77	2.04	1.81	1.34	
	55	2.95	2.91	2.54	1.86	1.55	1.22	3.33	3.27	2.86	2.09	1.86	1.38	
	60	3.07	3.01	2.65	1.91	1.59	1.24	3.46	3.38	2.99	2.15	1.90	1.39	
	65	3.18	3.16	2.73	1.96	1.63	1.27	3.58	3.55	3.08	2.20	1.95	1.43	
	70	3.29	3.26	2.81	2.01	1.67	1.30	3.71	3.67	3.17	2.26	2.00	1.46	
	75	3.41	3.36	2.89	2.08	1.71	1.33	3.84	3.78	3.26	2.34	2.05	1.50	
	80	3.52	3.46	2.96	2.13	1.75	1.35	3.97	3.89	3.34	2.40	2.10	1.51	
	85	3.64	3.56	3.08	2.18	1.79	1.38	4.10	4.00	3.48	2.46	2.14	1.55	
	90	3.75	3.66	3.16	2.23	1.83	1.41	4.22	4.12	3.56	2.51	2.19	1.58	
	95	3.86	3.76	3.24	2.28	1.87	1.44	4.35	4.23	3.65	2.57	2.24	1.62	
	100	3.98	3.86	3.32	2.33	1.91	1.45	4.48	4.34	3.74	2.62	2.29	1.63	
	RAINFALL	5.68	5.01	3.90	2.48	2.01	1.53	6.40	5.64	4.40	2.79	2.41	1.72	

**P.I. VALUES FOR VARIOUS IMPERVIOUS CONDITIONS**  
(10 YEAR & 15 YEAR RAINFALL FREQUENCIES)

P.I. Values for 10 Year & 15 Year Rainfall Frequencies  
**Table 8.2**

Section 8 Storm Drainage Facilities

P.I. FACTOR IN CUBIC FEET PER SECOND PER ACRE																
DURATION OF RAIN IN MINUTES	% IMPERVIOUS	2-YEAR RAINFALL FREQUENCY					5-YEAR RAINFALL FREQUENCY									
		15	20	30	60	90	120	15	20	30	60	90	120			
	0	1.20	1.23	1.12	0.88	0.77	0.64	1.48	1.52	1.39	1.09	0.96	0.79			
	5	1.28	1.30	1.18	0.92	0.79	0.66	1.57	1.61	1.45	1.13	0.99	0.82			
	10	1.36	1.37	1.26	0.97	0.82	0.68	1.67	1.70	1.55	1.20	1.03	0.84			
	15	1.44	1.44	1.32	1.00	0.85	0.71	1.77	1.78	1.62	1.24	1.06	0.87			
	20	1.52	1.54	1.37	1.04	0.88	0.72	1.87	1.91	1.69	1.28	1.09	0.88			
	25	1.60	1.61	1.42	1.07	0.90	0.74	1.97	2.00	1.76	1.33	1.13	0.91			
	30	1.68	1.68	1.48	1.11	0.93	0.76	2.07	2.09	1.83	1.37	1.16	0.94			
	35	1.76	1.76	1.56	1.14	0.96	0.78	2.16	2.18	1.93	1.41	1.20	0.96			
	40	1.84	1.83	1.62	1.18	0.99	0.79	2.26	2.26	1.99	1.46	1.23	0.98			
	45	1.92	1.90	1.67	1.23	1.01	0.81	2.36	2.35	2.06	1.52	1.27	1.00			
	50	2.00	1.97	1.73	1.26	1.03	0.83	2.46	2.44	2.13	1.56	1.28	1.03			
	55	2.08	2.04	1.78	1.30	1.05	0.86	2.56	2.52	2.20	1.61	1.32	1.06			
	60	2.16	2.11	1.86	1.33	1.08	0.87	2.66	2.61	2.30	1.65	1.35	1.07			
	65	2.24	2.21	1.92	1.37	1.11	0.89	2.76	2.74	2.37	1.69	1.39	1.10			
	70	2.32	2.28	1.97	1.40	1.14	0.91	2.85	2.83	2.43	1.73	1.42	1.12			
	75	2.40	2.35	2.03	1.45	1.16	0.93	2.95	2.91	2.50	1.80	1.45	1.15			
	80	2.48	2.42	2.08	1.49	1.19	0.94	3.05	3.00	2.57	1.84	1.49	1.16			
	85	2.56	2.49	2.16	1.52	1.22	0.96	3.15	3.09	2.67	1.88	1.52	1.19			
	90	2.64	2.56	2.22	1.56	1.25	0.98	3.25	3.18	2.74	1.93	1.56	1.21			
	95	2.72	2.63	2.27	1.59	1.27	1.01	3.35	3.26	2.81	1.97	1.59	1.24			
	100	2.80	2.70	2.33	1.63	1.30	1.02	3.44	3.35	2.87	2.01	1.62	1.25			
	RAINFALL	4.00	3.51	2.74	1.73	1.37	1.07	4.92	4.35	3.38	2.14	1.71	1.32			

**P.I. VALUES FOR VARIOUS IMPERVIOUS CONDITIONS**  
(2 YEAR & 5 YEAR RAINFALL FREQUENCIES)

P.I. Values for 2 Year & 5 Year Rainfall Frequencies  
**Table 8.3**



Section 8 Storm Drainage Facilities

P.I. FACTOR IN CUBIC FEET PER SECOND PER ACRE													
DURATION OF RAIN IN MINUTES	% IMPERVIOUS	50-YEAR RAINFALL FREQUENCY					100-YEAR RAINFALL FREQUENCY						
		15	20	30	60	90	120	15	20	30	60	90	120
	0	2.32	2.38	2.16	1.71	1.66	1.24	2.58	2.66	2.42	1.91	1.92	1.39
	5	2.47	2.52	2.27	1.78	1.72	1.28	2.75	2.81	2.54	1.98	1.98	1.43
	10	2.62	2.66	2.43	1.88	1.78	1.32	2.92	2.96	2.71	2.09	2.05	1.48
	15	2.78	2.79	2.53	1.95	1.84	1.37	3.10	3.11	2.83	2.17	2.12	1.52
	20	2.93	3.00	2.64	2.02	1.89	1.39	3.27	3.34	2.95	2.24	2.19	1.55
	25	3.09	3.13	2.75	2.08	1.95	1.43	3.44	3.49	3.07	2.32	2.26	1.59
	30	3.24	3.27	2.85	2.15	2.01	1.47	3.61	3.64	3.19	2.39	2.33	1.64
	35	3.40	3.41	3.01	2.22	2.07	1.51	3.78	3.80	3.36	2.47	2.39	1.69
	40	3.55	3.54	3.12	2.28	2.13	1.53	3.96	3.95	3.48	2.54	2.46	1.71
	45	3.71	3.68	3.22	2.39	2.19	1.57	4.13	4.10	3.60	2.66	2.53	1.76
	50	3.86	3.81	3.33	2.45	2.22	1.61	4.30	4.25	3.72	2.73	2.57	1.80
	55	4.01	3.95	3.43	2.52	2.28	1.66	4.47	4.40	3.84	2.81	2.63	1.85
	60	4.17	4.09	3.59	2.59	2.34	1.68	4.64	4.55	4.01	2.88	2.70	1.87
	65	4.32	4.29	3.70	2.65	2.40	1.72	4.82	4.78	4.13	2.95	2.77	1.92
	70	4.48	4.43	3.80	2.72	2.46	1.76	4.99	4.93	4.25	3.03	2.84	1.96
	75	4.63	4.56	3.91	2.82	2.52	1.80	5.16	5.09	4.37	3.14	2.91	2.01
	80	4.79	4.70	4.01	2.89	2.58	1.82	5.33	5.24	4.48	3.22	2.98	2.03
	85	4.94	4.84	4.17	2.96	2.63	1.86	5.50	5.39	4.66	3.29	3.04	2.08
	90	5.10	4.97	4.28	3.02	2.69	1.90	5.68	5.54	4.78	3.37	3.11	2.13
	95	5.25	5.11	4.38	3.09	2.75	1.95	5.85	5.69	4.90	3.44	3.18	2.17
	100	5.40	5.24	4.49	3.16	2.81	1.97	6.02	5.84	5.02	3.52	3.25	2.19
	RAINFALL	7.72	6.81	5.28	3.36	2.96	2.07	8.60	7.59	5.90	3.74	3.42	2.31

**P.I. VALUES FOR VARIOUS IMPERVIOUS CONDITIONS**  
(50 YEAR & 100 YEAR RAINFALL FREQUENCIES)

P.I. Values for 50 Year & 100 Year Rainfall Frequencies  
**Table 8.4**

## Section 8 Storm Drainage Facilities

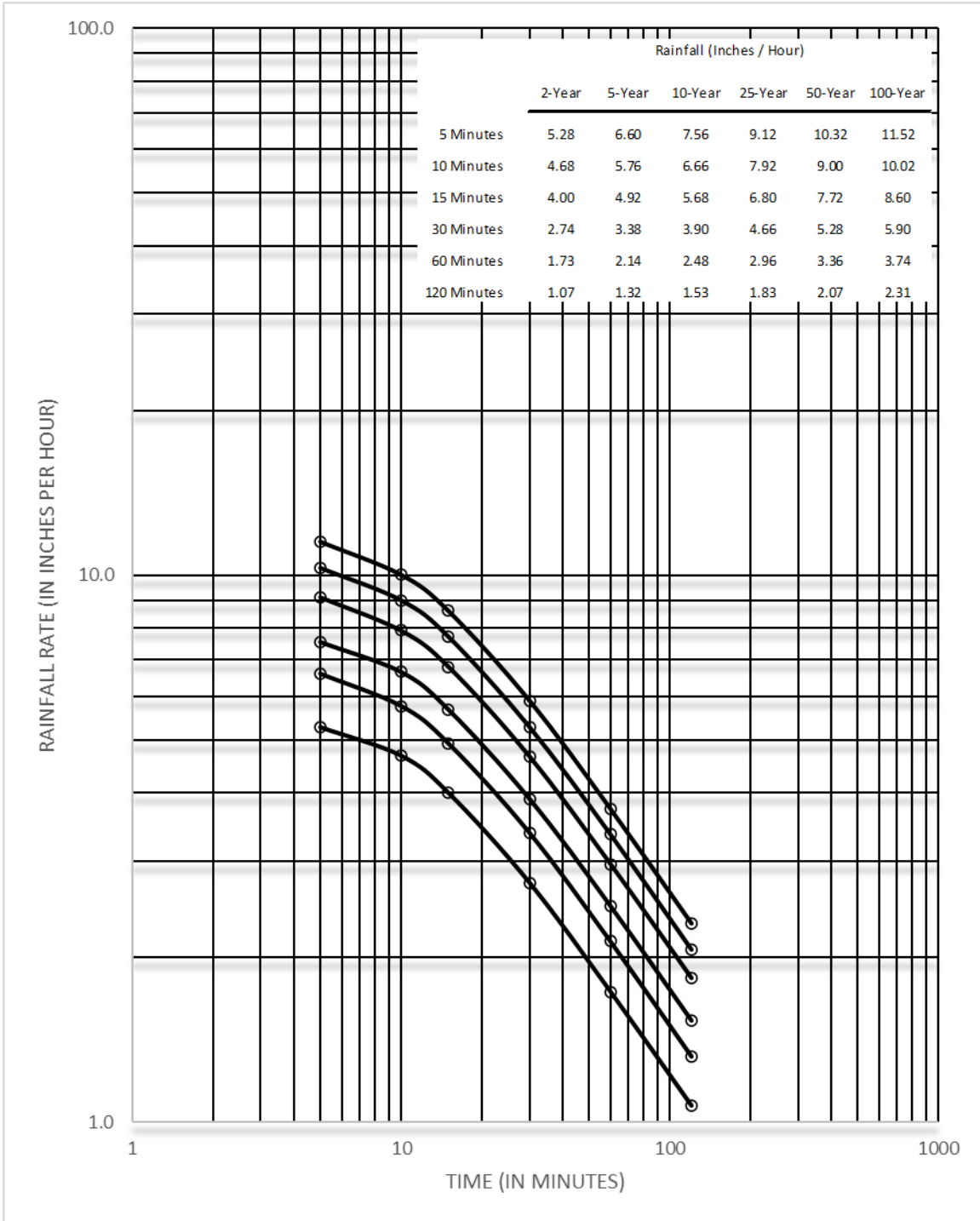

Rainfall Intensity - Duration Curves

**Figure 8.1**

Section 8 Storm Drainage Facilities

SYMBOLS

- D = DIAMETER OF PIPE
- r = RADIUS OF CURVE
- V = VELOCITY IN FT. PER SEC.
- K<sub>c</sub> = CURVE LOSS COEFFICIENT
- h<sub>c</sub> = HEAD LOSS DUE TO CURVED ALIGNMENT
- α = DEFLECTION ANGLE IN RADIANS
- C = FACTOR OF CONSERVATISM TO ACCOUNT FOR THE VARIATION IN THE EXPERIMENTAL DATA. FOR THESE CURVES C = 1.5 FOR THE DESIGN OF HYDRAULIC CAPACITY.
- L<sub>n</sub> = NATURAL LOG

$$K_c = C \frac{2\alpha}{\pi^2 (L_n \frac{r}{D} + \alpha)}$$

$$h_c = K_c \frac{V^2}{2g}$$

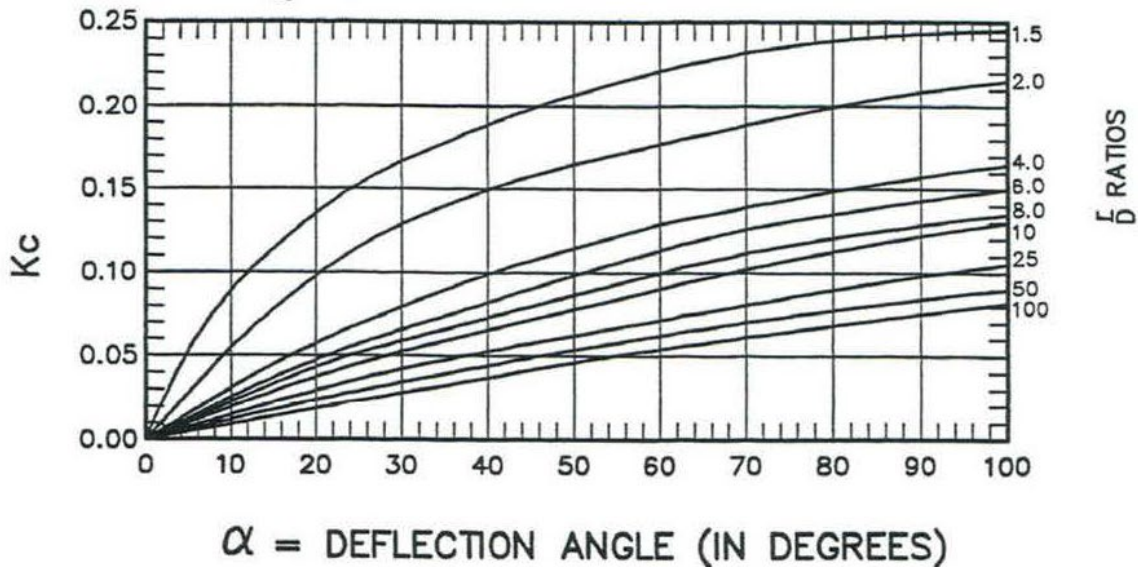

EXAMPLE

- Q = 260cfs      V = 13.2fps
- D = 60"        α = 90°
- r = 50'        V<sup>2</sup>/2g = 2.71'
- r/D = 10

FROM α = 90° ON THE ABSCISSA FOLLOW A VERTICAL LINE UP TO THE INTERSECTION WITH THE r/D = 10 CURVE. THEN TRANSFER ON A HORIZONTAL LINE TO THE ORDINATE AND READ THE CORRESPONDING CURVE LOSS COEFFICIENT

K<sub>c</sub> = 0.123

THE HEAD LOSS DUE TO CURVED ALIGNMENT =

$$h_c = K_c \frac{V^2}{2g} = (0.123)(2.71) = 0.33$$

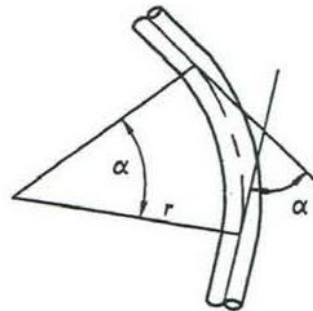

Head Loss for Curved Alignment of Concrete Pipes

Figure 8.2

Section 8 Storm Drainage Facilities

GENERAL NOTES:

1. DO NOT SCALE DRAWING. FOLLOW DIMENSIONS.
2. LOW POINT INLETS ARE CONTROLLED BY CAPACITY IN GUTTER BASED ON PERCENT OF GRADE OF THE GUTTER AT THE BEGINNING POINT OF THE STANDARD SUMP, E.G., 0.5% GRADE, 2% CROSS SLOPE, 3" DEEP,  $0.02N=2.1$  C.F.S.
3. ASSUME INLET INTERCEPTS 100% OF FLOW.

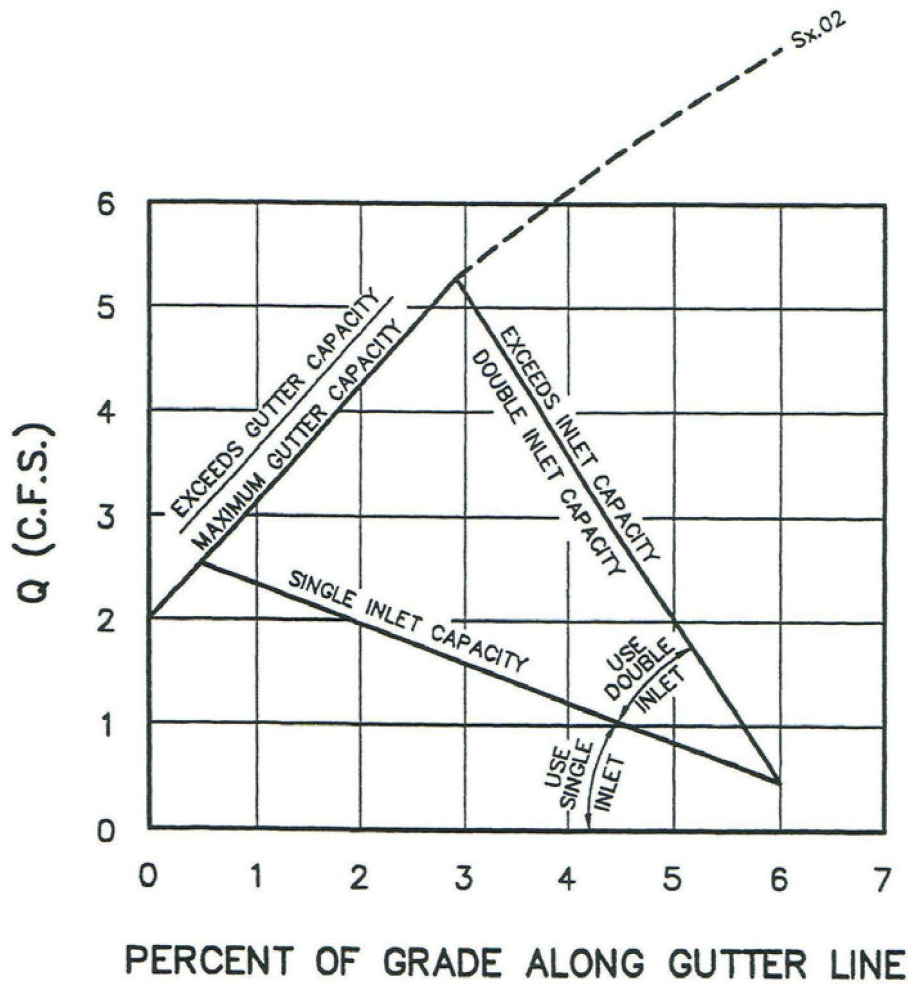

Inlet and Gutter Intercept Capacity Chart

Figure 8.3

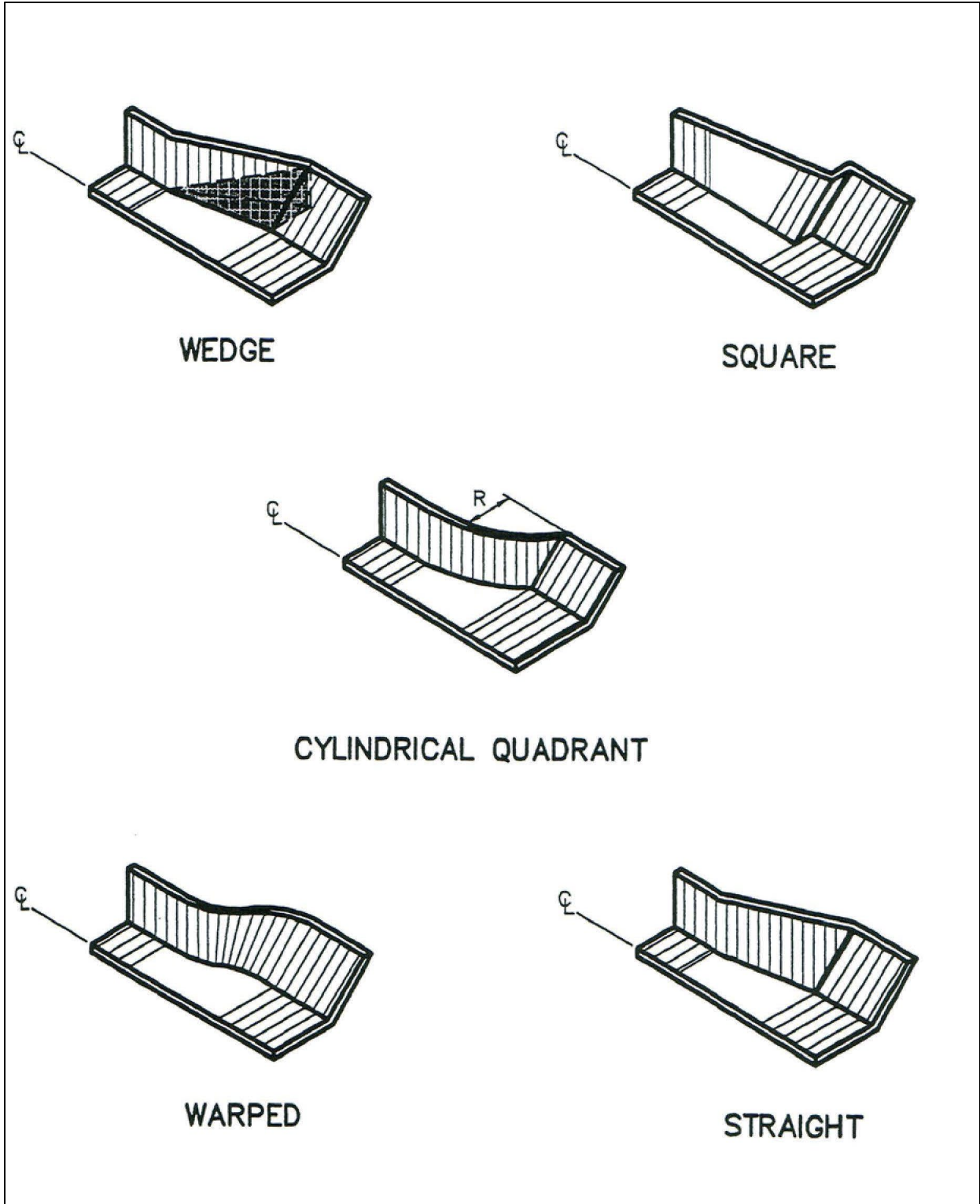

Transition Types for Rectangular Channels

Figure 8.4

## Section 9 Sanitary Sewer Facilities

### 9.010 General

This Section gives the minimum technical design requirements of the City for sanitary sewerage and sewage treatment facilities. In general, the formulae presented herein for hydraulic design represent acceptable procedures not necessarily to the exclusion of other sound and technically supportive formulae. Any departure from these design requirements shall be brought to the attention of the City and discussed before the submission of plans for approval, with justification. Minimum standards specified by the Illinois Environmental Protection Agency shall be followed instances not governed in the section or directed by the City. All construction details pertaining to sanitary sewer improvements shall be prepared in accordance with “*Standard Specifications for Water and Sewer Construction in Illinois*” unless otherwise noted.

If the public sewer system is within seven hundred fifty (750) of a proposed subdivision or development, and said system has the available capacity, the developer shall extend the existing system and sewer to the entire proposed development at the developer’s own expense.

Whenever the existing public sanitary sewer system is to be extended for a proposed development, the developer shall have detailed construction plans prepared by a professional engineer registered in the State of Illinois. The plans and necessary permit application papers required by the Illinois Environmental Protection Agency shall be submitted to the City for approval by the City Engineer. For subdivisions, the developer must install a six (6) inch service tap for each lot to be served with sufficient six (6) inch service line to place the service a minimum of five (5) feet beyond the lot line of each lot.

### 9.020 General Requirements of Sanitary Sewer Construction

All sanitary sewers shall meet the following general requirements:

#### 9.020.01 Size and Shape

The minimum diameters of pipe for sanitary sewers shall be eight (8) inches. Sewers shall not decrease in size in the direction of the flow. Circular pipe sewers shall be used for all sizes of sanitary sewers.

#### 9.020.02 Materials

All materials shall conform to the “*Standard Specifications for Water and Sewer Construction in Illinois*”.

All sewers mains shall have a copper tracer wire installed with the main to allow future underground location. The tracer wire shall be THWN soft drawn No. 12 copper and shall be wrapped around outside of all manholes and connected to a ground rod. All underground splices shall be made with silicone filled wire nuts.



**9.020.03 Bedding and Backfill**

The project Plans and Project Specifications shall indicate the specific type or types of bedding, cradling, or encasement required in the various parts of the sanitary sewer construction if different than the current *“Standard Specifications for Water and Sewer Construction in Illinois”*.

Special design and bedding provisions shall be made for pipes laid under or over fills or embankments in shallow or partial trenches either by specifying extra strength pipe for the additional loads due to differential settlement, or by special construction methods, including ninety (90%) modified proctor compaction of fill, to prevent or minimize such additional loads. Special considerations shall be made for pipe material and bedding for unsuitable soil conditions or other conditions within the project area that may affect the pipe design.

Compacted granular backfill shall be required in all trench excavation within public (or private) streets rights-of-way or area where street rights-of-way are anticipated to be dedicated for public use. Under area to be paved, the compacted granular backfill shall be placed to the subgrade of the pavement. Under unpaved areas, the compacted granular backfill shall be placed to within two (2) feet of the finished surface, and generally not more than two (2) feet beyond street pavement or curb lines. For new residential developments, in areas outside of street right-of-way, where private driveways are not yet constructed, granular backfill will not be required. If the storm and sanitary sewers are parallel and in the same trench, the upper pipe shall be placed on a shelf and the lower pipe shall be bedded in compacted granular fill to the flowline of the upper pipe. If the sewers are within eighteen (18) inches of each other, the lower pipe shall be concrete encased.

**9.020.04 Pipe or Conduit Under Streets and Pavements**

Any pipe or conduit material beneath a highway, road, street or pavement, or with reasonable probability of being so located, shall have ample strength for all vertical loads, including live load required by the highway authority having jurisdiction, but in no case shall provide for less than an AASHTO HS-20 loading. Special considerations may be required for adverse conditions. Compacted granular backfill shall be utilized to the base of the pavement. For new residential site developments, in areas outside of street right-of-way, where private driveways are not yet construct, granular backfill will not be required.

**9.020.05 Joints**

The joint type required for the type of pipe used and the application shall conform to the latest standards set forth in the *“Standard Specifications for Water and Sewer Construction in Illinois”* or as approved by the City.

**9.020.06 Monolithic Structures**

Monolithic reinforced concrete structures shall be designed structurally as continuous rigid units. Wall thickness shall be eight (8) inches minimum with one row of reinforcement, horizontal and vertical. Wall thickness ten (10) inches and greater shall require two rows of reinforcement, horizontal and vertical. Where approved, IDOT precast structures are allowed, less steel and thickness may be accepted.

**9.020.07 Alignment**

Sanitary sewer alignments are normally limited by the available easements, which in turn should reflect proper alignment requirements.

Sanitary sewers shall be aligned:

1. To be in a straight line between structures for all pipe sewers thirty (30) inches in diameter and smaller.
2. To be parallel with or perpendicular to the centerlines of straight streets unless otherwise unavoidable. Deviations may be made only with approval of the City.
3. To avoid meandering, off-setting and unnecessary angular changes.
4. To make angular changes in alignment for sewers thirty (30) inches in diameter or smaller in a manhole located at an angle point and for sewer thirty-three (33) inches in diameter or larger, by a uniform curve between two tangents. Curves shall have a minimum radius of ten times the pipe diameter.
5. To avoid angular changes in direction greater than necessary and any exceeding ninety (90) degrees.

**9.020.08 Location**

Sanitary sewers locations are determined primarily by the requirements of service and purpose. Sanitary sewers in the right-of-way are generally located along the center of the street. It is also necessary to consider accessibility for construction and maintenance, site availability and competing uses, and effects of easements on private property.

Sanitary Sewers shall be located:

1. To serve all property conveniently and to best advantage.
2. In public streets, road, alleys, rights-of-way, or in sewer easements dedicated to the City.
3. In easements on private property only when unavoidable.



## Section 9 Sanitary Sewer Facilities

4. On private property along property lines or immediately adjacent to public street, avoiding crossing through the property.
5. At a sufficient distance from existing and/or proposed buildings (including footings) and underground utilities or other sewers to avoid encroachment and reduce construction hazards.
6. In unpaved or unimproved areas whenever possible.
7. To avoid, whenever possible, any locations known to be or probably to be beneath curbs, paving or other improvements particularly when laid parallel to centerlines.
8. To avoid sinkholes and creeks.
9. No sanitary lateral clean outs or sampling tees shall be placed within the area of the stormwater overflow path.
10. No sanitary sewer shall be within ten (10) feet horizontally or eighteen (18) inches vertically of a water main, or as allowed by IAC Title 35 Section 653.119.

### 9.020.09 **Flowline**

The flowline of the sanitary sewer shall meet the following requirements:

1. The flowline shall be straight or without gradient change between the inner walls of connected structures.
2. Gradient changes in successive reaches normally shall be consistent and regular, with small or insignificant differences in successive reaches. Gradient designations less than the nearest 0.001 foot per foot, except under special circumstances and for larger sewers, shall be avoided.
3. For sanitary sewers the hydraulic grade line shall not rise above the inside top of the sewer pipe.
4. When the grade of a sewer is twenty (20) percent or greater, a concrete cradle or collar at each pipe joint is required. For grades exceeding fifty (50) percent a special design and project specifications are required.

### 9.020.10 **Manholes**

Manholes provide access to sewers for purposes of inspection, maintenance and repair. They also serve as junction structures for connecting lines. Requirements of sewer maintenance determine the main characteristics of manholes.

## Section 9 Sanitary Sewer Facilities

1. Manholes shall be located at changes in direction, changes of pipe size, changes of flowline gradient, and at junction points with connecting sewers.

For sewers thirty-three (33) inches in diameter and larger, manholes shall be located on special structures at junction points with other sewers and at changes of size, alignment, or gradient. These special structures are identified as Junction Structures, and are described further in [Section 9.030.09](#). A manhole shall be located at each end of a short or long curve.

2. Spacing of manholes shall not exceed four hundred (400) feet for pipe sewers thirty-six (36) inches in diameter and smaller, five hundred (500) feet for pipe sewers forty-two (42) inches in diameter and larger, except under special approved conditions. Spacing shall be approximately equal, whenever possible.

In addition, street access manholes should be located at a spacing of not more than 1200 feet apart to facilitate sewer maintenance requirements. "Street access manholes" are those manholes in or adjacent to a paved street accessible to the City.

3. Manholes on sanitary sewers eight (8) inches through thirty-six (36) inches shall be a minimum of forty-eight (48) inches in diameter and/or have a square bottom section with sides of forty-eight (48) inches, depending on the sewer diameter. Manholes on sewers greater than thirty-six (36) inches in diameter shall be built in accordance with the *"Standard Specifications for Water and Sewer Construction in Illinois"*.
4. At stream and channel crossings, manholes shall be a minimum of ten (10) feet horizontally back from the top of the bank on both sides of the crossing.
5. All manholes on sanitary sewers that are built in existing or proposed areas subject to flooding or ponding, or within the 100-year flood limits, the stormwater overflow path, swales, or ditches, or in other areas determined to be subject to flooding or ponding, shall be provided with lock type, sealing, watertight manhole frames and covers, R-1916-D, as manufactured by Neenah Foundry Company, or equivalent, conforming to AASHTO M-105. This requirement applies to newly constructed manholes, as well as existing manholes that are to be adjusted to grade or otherwise modified or connected into. All other manholes shall be provided with standard frames and cover, R-1015, as manufactured by Neenah Foundry Company, or equivalent, conforming to AASHTO M-105.
6. Manholes for sanitary sewers shall be precast concrete or poured in place type and waterproofed on the exterior, as approved by the City.

### 9.020.11 Sewage Treatment Facilities

1. New treatment plants will not be allowed.
2. Treatment using a septic system for continued use of an existing individual residence may be considered only where the City determines that no public sanitary sewer is available. Availability of sanitary sewers is assumed if any point on the property to be served is within a distance of two hundred fifty (250) feet of a public sanitary sewer, per Section 13.16.080 of the Collinsville Municipal Code. In any case, the City will make the final determination based on specific site conditions.
3. Where sanitary sewers are unavailable under the provisions of Section 13.16.080 of the Collinsville Municipal Code, the building sewer shall be connected to a private sewage disposal system complying with the provisions of Section 13.16.080 of the Collinsville Municipal Code.

## 9.030 Design Requirements

### 9.030.01 General

All sanitary sewers shall be designed and constructed to conform to these design requirements. Hydraulic calculations must be submitted as part of the plan review for all public sewer construction. Calculations must be submitted for the existing and ultimate upstream development condition.

### 9.030.02 Gradients

The following minimum slopes of sanitary pipe sewers are those giving at least three (3) feet per second velocities flowing full, based on Manning's formula using an "n" value of 0.013 unless otherwise directed by the City. Slopes greater than these minimums shall be used whenever possible. Variation from these minimums will only be considered by the City under extenuating circumstances due to existing and unavoidable site conditions.

For sewers with a design grade less than one (1) percent, field verification of the pipe grade will be required for each installed reach of sewer, prior to any surface restoration or installation of any surface improvements.

The City may require the submittal of revised hydraulic calculations for any sewer reach having an as-built grade flatter than the design grade by more than 0.1%. Base on a review of the hydraulic information, the City may require the removal and replacement of any portion of a sewer required to ensure sufficient hydraulic capacity and cleansing velocity of the system.

Pipes Larger than thirty-six (36) inches in diameter shall maintain a minimum cleansing velocity of two (2) feet per second. Where velocities are greater than 15 feet per

## Section 9 Sanitary Sewer Facilities

second, special provisions to protect against displacement by erosion and impact shall be made.

Pipe Size	Minimum Slope in Ft. per 100 Ft (% Grade)
6 (house lateral)*	1.1
8	0.40
10	0.28
12	0.22
15	0.15
18	0.12
21	0.10
24	0.08
27	0.067
30	0.058
36	0.046

Minimum Slope for Pipe Size

**Table 9.1**

### 9.030.03 Depth and minimum Cover

Sewer depths shall be determined primarily by the requirements of pipe or conduit size, utility obstructions, required connections, future extensions, and adequate cover. The minimum depth requirements shall be as follows:

1. For sewers which may be extended in the future, the minimum depth shall be nine (9) feet below the finish grade to flowline, except where upstream topography indicates that this depth is not necessary as determined by the City.
2. The minimum depth of sewers shall not be less than three (3) feet plus the sewer diameter. The flowline of the sewer must have a vertical distance from the low point of a basement or low floor of not less than 2.5 feet plus the sewer diameter. The minimum depth shall be increased as required to insure a minimum 1.1 percent slope and 2.5 feet of cover for a six (6) inch house lateral.
3. At stream and channel crossings, a minimum depth of three (3) feet shall be allowed where greater depths cannot be achieved. Where this minimum cover cannot be achieved, a casing pipe shall be installed to encase the sewer unless otherwise directed by the City. Stream and channel crossings must be protected with rock blanket or other approved bank stabilization/channel protection methods. Concrete encasement is not an option. Aerial crossings are not allowed unless attached to a bridge.

## Section 9 Sanitary Sewer Facilities

4. Sewer depths at manholes shall be sufficient to ensure the use of standard manholes. Special manholes will only be allowed upon approval by the City.
5. In situations where fill is being added, minimal cover is proposed, or the sewer is being subjected to additional live or dead load, as directed by the City the design engineer shall provide structural calculations to verify the sewer is able to support the proposed loading.

### 9.030.04 Flow Design

Proposed flow for domestic sewage discharge shall be determined in accordance with Subpart C of the IRSSW except that the peaking factor shall be 4.0 in all instances. Proposed flow for commercial and industrial sewage discharge shall be based on projected population equivalents for proposed facilities.

### 9.030.05 Population Factors

The population factor used shall be based on residence type according to [Table 9.2](#).

Residence Type	Number of Persons
Efficiency or Studio Apartment	1
1 Bedroom Apartment	1.5
2 Bedroom Apartment	3
3-Bedroom Apartment	3.7
Single Family Dwelling	3.7
Mobile Home	2.5

Population Factors

**Table 9.2**

**9.030.06 Sanitary Flow Table**

Population Unit	Flow (cfs)
One Person @ 400 G/D	0.00062
Efficiency or Studio Apartment @ 1.0 Persons @ 400 G/C/D	0.00062
1 Bedroom Apartment @1.5 Persons @ 400 G/C/D	0.00093
2 Bedroom Apartment @3.0 Persons @ 400 G/C/D	0.00186
3 Bedroom Apartment @3.7 Persons @ 400 G/C/D	0.00229
Single Family Dwelling @3.7 Persons @ 400 G/C/D	0.00229
Mobile Home @2.5 Persons @ 400 G/C/D	0.00155

Sanitary Flow  
**Table 9.3**

G/C/D = Gallons per Capita per Day

Basic Formula:

$$\text{Flow (CFS)} = \text{Population} \times \text{Flow (in G/C/D)} / 646,317$$

**9.030.07 Hydraulic Grade Line**

1. Hydraulic Grade Line Limits

The hydraulic grade line for sanitary sewers shall not rise above the inside top of the sewer pipe.

The beginning point of the hydraulic grade line computations shall be the higher (i.e. more conservative) elevation as determined below:

For connection to existing pipe systems

- A. The inside top of the sewer pipe or inlet control calculation at least two reaches downstream of the connection point to the existing system; or
- B. The hydraulic grade line computed for the existing system, especially where the

## Section 9 Sanitary Sewer Facilities

downstream system has suspected or known lack of capacity issues.

Field verified structure and flowline elevations, pipe sizes and characteristics shall be used.

### 2. Computation Methods

Sanitary sewers shall be designed to flow not more than 80% full at ultimate peak design flow conditions. Their hydraulic grade line shall be computed to show its elevation at manholes, transition structures, and junction points of flow in pipes, and shall provide for the losses and the differences in elevations as required below.

#### A. Friction Loss

The major energy loss in a sanitary sewer will be the energy loss due to friction. It is determined by the equation:

$$h_f = L \times S_h$$

Where:

$h_f$  = difference in water surface elevation, or head in feet in length L due to friction

L = length in feet of pipe or channel

$S_h$  = hydraulic slope required for a pipe of given diameter and for a given roughness "n", expressed as feet of slope per foot of length

From Manning's formula:

$$S_h = [(V)(n)/(1.486 R^{0.667})]^2$$

Where:

R = hydraulic radius of pipe or conduit in feet

V = velocity in feet per second

n = Manning's value for coefficient of roughness; where

n = 0.013 for concrete, vitrified clay and plastic pipe;

n = 0.012 for concrete pipe greater than forty-eight (48) inches in diameter or greater

#### B. Curve Loss

Curve loss in pipe flow is the additional head required to maintain the required flow because of curved alignment, and is in addition to the friction loss of an

## Section 9 Sanitary Sewer Facilities

equal length of straight alignment. If concrete pipe, it may be evaluated from [Figure 8.2](#) which includes an example.

### C. Turn Loss

Head losses in manholes due to change in flow (turns) will be determined in accordance with the following:

<u>Change in Direction of Flow (A)</u>	<u>Multiplier of Velocity Head of Water Being Turned (K)</u>
90 Deg.	0.7
60 Deg.	0.55
45 Deg.	0.47
30 Deg.	0.35
15 Deg.	0.18
0 Deg.	0.0
Other Angles	By Interpolation

DIAGRAM

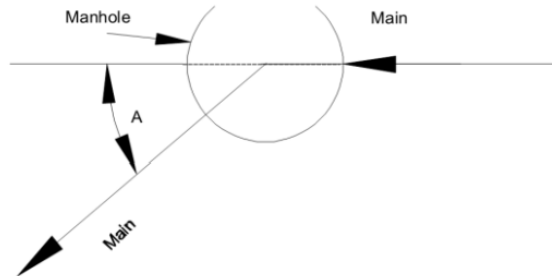

Formula:  $H_L = K(V_L)^2/2g$

Where:

$H_L$  = Feet of head lost in manhole due to change in direction of pipe flow

$V_L$  = Velocity of flow in pipe in ft/sec

$g$  = Acceleration of gravity, 32.2 ft/sec/sec

$K$  = Multiplier of Velocity Head of water being turned

### D. Junction Chamber Loss



## Section 9 Sanitary Sewer Facilities

A sewer junction occurs for large pipes or conduits too large to be brought together in a forty two (42) inch diameter manhole where one or more branch sewers enter a main sewer. Allowances should be made for head loss due to curvature of the paths due to impact at the converging streams.

Losses in a junction chamber for combining large flows shall be minimized by setting flowline elevations so that pipe centerlines (spring lines) will be approximately in the same planes.

A computation method for determining junction chamber losses is presented below:

$$H_j = y + V_{h1} - V_{h2}$$

Where:

$H_j$	=	junction chamber loss (ft)
$V_{h1}$	=	upstream velocity head
$V_{h2}$	=	downstream velocity head
$y$	=	change in hydraulic grade line through the junction in feet

Where:

$$y = \frac{[(Q_2 V_2) - (Q_1 V_1) + \{(Q_3 V_3 \cos \theta_3) + (Q_n V_n \cos \theta_n)\}]}{0.5(A_1 + A_2)g}$$

Where:

$Q_2$	=	Discharge in cubic feet per second (cfs) at the exiting conduit
$V_2$	=	Velocity in feet per second (fps) at the exiting conduit
$A_2$	=	Cross section area of flow in sq. ft. for the exiting conduit
$Q_1$	=	Discharge in cfs for the incoming pipe (main flow)
$V_1$	=	Velocity in fps for the incoming pipe (main flow)
$A_1$	=	Cross section area of flow in sq. ft for the incoming pipe (main flow)
$Q_3, Q_n$	=	Discharge(s) in cfs for the branch lateral(s)
$V_3, V_n$	=	Velocity(ies) in fps for the branch lateral(s)
$\theta_3, \theta_n$	=	The angle between the axes of the exiting pipe and the branch lateral(s)
$g$	=	Acceleration of gravity, 32.2 ft/sec/sec

Where:

$\theta$  = is the angle between the axes of the outfall and the incoming laterals

### E. Losses at Junctions of Several Flows in Manholes

## Section 9 Sanitary Sewer Facilities

The computation of losses in a manhole with several flows entering the structure should utilize the principle of the conservation of energy. This involves both the elevation of water surface and momentum (mass times the velocity head). Thus, at a manhole with two or more incoming pipes, the sum of the energy content for inflows is equal to the sum of the energy content of the outflows plus the additional energy required by the turbulence of the flows passing through the structure.

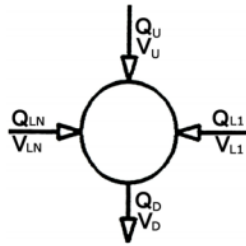

The upstream hydraulic grade line may be calculated as follows:

$$H_U = \left[ \frac{V_D^2}{2g} \right] - \left[ \left( \left( \frac{Q_U}{Q_D} \right) (1 - K) \left( \frac{V_U^2}{2g} \right) \right) + \left( \left( \frac{Q_{L1}}{Q_D} \right) (1 - K) \left( \frac{V_{L1}^2}{2g} \right) \right) + \left( \left( \frac{Q_{LN}}{Q_D} \right) (1 - K) \left( \frac{V_{LN}^2}{2g} \right) \right) \right] + H_D$$

Where:

- $H_U$  = Upstream hydraulic grade line in feet
- $Q_U$  = Upstream main line discharge in cubic feet per second
- $Q_D$  = Downstream main line discharge in cubic feet per second
- $Q_{L1}$ - $Q_{LN}$  = Lateral discharges in cubic feet per second
- $V_U$  = Upstream main line velocity in feet per second
- $V_D$  = Downstream main line velocity in feet per second
- $V_{L1}$ - $V_{LN}$  = Lateral velocities in feet per second
- $H_D$  = Downstream hydraulic grade line in feet
- $K$  = Multiplier of Velocity of Water being turned
- $g$  = Acceleration of gravity, 32.2 ft/sec/sec

The above equation does not apply when two (2) almost equal and opposing flows, each perpendicular the downstream pipe, meet and no other flows exist in the structure. In this case the head loss is considered as the total velocity head of the downstream discharge.

### F. Transition Loss

## Section 9 Sanitary Sewer Facilities

The relative importance of the transition loss is dependent on the velocity head of the flow. If the velocity and velocity head of the flow are quite low, the transition losses cannot be very great. However, even small losses may be significant in flat terrain. The sewer design shall provide for the consideration of the necessary transitions and resulting energy losses. The possibility of objectionable deposits is to be considered in the design of transitions.

For design purposes it shall be assumed that the energy loss and changes in depth, velocity and invert elevation, if any, occur at the center of the transition. These changes shall be distributed throughout the length of the transition in actual detailing. The designer shall carry the energy head, piezometric head, and invert as elevations, and work from the energy grade line.

### Closed Conduits

Transitions in small sewers may be confined within a manhole. Special structures may be required for larger sewers. If a sewer is flowing surcharged, the form and friction losses are independent of the invert slope; therefore, the transition may vary at the slopes of the adjacent conduits. The energy loss in a transition shall be expressed as a coefficient multiplied by the change in velocity head ( $V^2/2g$ ) in which V is the change in velocity before and after the transition. The coefficient may vary from zero to one, depending on the design of the transition.

If the areas before and after a transition are known, it is often convenient to express the transition loss in terms of the area ratios and either the velocity upstream or downstream.

For an expansion:

$$H_L = \frac{K(V_1 - V_2)^2}{2g} \approx \left[ \frac{KV_1^2}{2g} \right] \left[ 1 - \left( \frac{A_2}{A_1} \right) \right]^2$$

In which HL is the energy loss; K is a coefficient equal to 1.0 for a sudden expansion and approximately 0.2 for a well-designed transition and the subscripts 1 and 2 denote the upstream and downstream sections, respectively, i.e., A1 = Area Before Transition and A2 = Area After Transition.

For a contraction:

## Section 9 Sanitary Sewer Facilities

$$H_L = \left[ \frac{KV_2^2}{2g} \right] \left[ \frac{1}{C_c} - 1 \right]^2 \approx \left[ \frac{KV_2^2}{2g} \right] \left[ 1 - \frac{A_2}{A_1} \right]^2$$

in which K is a coefficient equal to 0.5 for a well-designed transition,  $C_c$  is a coefficient of contraction, and the other terms and subscripts are similar to the previous equation. Losses in closed conduits of constant area are expressed in terms of  $(V^2/2g)$ .

The above equations may be applied to approximate the energy loss through a manhole for a circular pipe flowing full. If the invert is fully developed, that is, semi-circular on the bottom and vertical on the sides from one-half depth up to the top of the pipe, for the expansion  $(A_1/A_2) = 0.88$ , and for the contraction  $(A_2/A_1) = 0.88$ . The expansion is sudden; therefore,  $K = 1$ . The contraction may be rounded if the downstream pipe has a bell or socket. In this case, K may be assumed to be 0.2.

The expansion energy loss is  $0.014[V^2/2g]$  and the contraction energy loss is  $0.010[V^2/2g]$ . Thus it may be seen that if the invert is fully developed, the manhole loss is small.

### 9.030.08 Infiltration

An additional amount of flow due to infiltration shall be evaluated. All sanitary sewers shall be limited to a maximum of two hundred (200) gallons per inch of pipe diameter per mile per day of line, as required by IEPA Specifications, when tested by appropriate water of low pressure testing. In addition, there shall be no visible leaks.

### 9.030.09 Special Situations and Design Requirements

1. Connections to Manholes
  - A. The invert of incoming sanitary sewers shall enter the manhole at the manhole flowline elevation. Under special circumstances, and only as approved by the City, up to two (2) foot interior free-fall drop will be allowed for incoming sewers. Such special circumstances may include sewer construction in bed rock or utility conflicts.
  - B. If it is necessary to enter a manhole with a force main this should be done within twelve (12) inches of the flowline of the manhole, and the manhole invert should be shaped to insure proper flow through the structure. Consideration shall be given to the detention time of the sewage in the force main, and the potential detrimental effects of the release of hydrogen sulfide

## Section 9 Sanitary Sewer Facilities

from the force main on the concrete structure of the manhole. Where it is determined that the release of hydrogen sulfide may be a problem, the concrete manhole shall be protected by a cementitious or plastic liner or epoxy coating, as approved by the City. Prior to the manhole lining, existing manhole steps that are in poor condition, or are without copolymer polypropylene plastic exterior, shall be removed flush with manhole interior wall, and then new standard manhole replacement steps as approved by the City shall be installed. Prior to the manhole lining, each step shall be wrapped except for the initial 2" portion protruding from the wall; this is to allow new manhole lining to completely cover the initial 2" of each step out from the manhole wall. Wrap to be removed after manhole liner completely cures.

Connection of a public force main to a manhole will require manhole lining protection for at least one manhole and possibly as many as five (5) downstream. Connection of a private forced lateral may require similar protection.

- C. The number of sewers coming into one manhole should be kept to a minimum. A Special detail may be required to assure the proper constructability and maintenance of the structure, especially for larger pipes, angled approaches or multiple incoming pipes.
- D. Pipes entering and exiting manholes at the flowline should project toward the center of the structure and the manhole invert should be shaped to assure proper flow through the structure.
- E. Private house lateral connections should be made to the main sewer, at existing wyes of record. In the absence of a wye, connect to the public sewer pipe using another approved method, and not to the manholes unless an 8 inch or large private sewer is connecting to an 8 inch or larger public sewer.
- F. All connections to sanitary manholes are subject to City review and approval and will be made at the City's discretion.
- G. Connections to existing structures may require rehabilitation or reconstruction of the structure being utilized. This work shall be considered part of the project being proposed.
- H. Junction Structure shall be required to have a ground surface access with a minimum of a standard 48" diameter manhole riser section(s). The junction structure flow channels and benches shall be built into the bottom of the structure. The entry angle from a sewer connection from the side shall not

## Section 9 Sanitary Sewer Facilities

exceed 20 degrees as measured between the centerlines of the two sewers being connected.

### 2. Adjusting Manholes to Grade

When a project requires a manhole to be adjusted to grade, a maximum of twelve (12) inches of rise is allowed if not previously adjusted. When adjustments to raise or lower a manhole are required, the method of adjustment must be stated on the project plans and approved by the City. Metal grade rings shall not be allowed.

### 3. Storm Sewers Crossing Over Sanitary Sewers

When a new storm pipe crosses over a new sanitary sewer and the vertical clearance is less than two (2) feet, a water main quality pipe must be installed as a casing pipe around the sewer, through the crossing and for ten (10) lineal feet each side of the crossing unless otherwise directed by the City. When new storm pipe crosses over an existing sanitary sewer and the vertical clearance is less than two (2) feet, the sanitary sewer shall be protected and the upper half of the sanitary sewer shall be carefully exposed and then concrete encased within the limits of the new storm sewer trench.

### 4. Location in Conjunction with Water Main

No cross connections. Outer limit of sanitary sewers and manholes shall be at least ten (10) feet horizontally from outer limit of any existing or proposed water main. Sewers and water mains shall be placed in separate trenches. If this is not possible, the water main shall be placed on an undisturbed earth shelf, the bottom of the water main shall be at least 18 inches above the top of the sewer, and the sewer must be constructed of slip-on or mechanical joint pipe or continuously encased and pressure tested to 150 psi to assure watertightness.

On crossings, a minimum of vertical clearance of eighteen (18) inches shall be provided between the outside of the water main and outside of the sanitary sewer. Sewer pipe joints shall be equidistant and as far as possible from the water main joints. Where a water main crosses under a sewer, adequate structural support shall be provided for the sewer to maintain line and grade as directed by the City Engineer.

If it is not possible to obtain proper horizontal and vertical separation, either:

- A. The sewer shall be designed and constructed of equal to water pipe and pressure tested to assure water tightness prior to backfilling, or

## Section 9 Sanitary Sewer Facilities

- B. Water main or sewer line is continuously encased or enclosed in a watertight carrier pipe of approved material which extends 10 feet in both directions, measured perpendicular to the water main.

### 5. Sanitary Sampling Appurtenance

A sanitary sampling appurtenance (“T” or manhole) is required for non-residential, commercial, and industrial projects. A sampling appurtenance shall be located on each private building lateral, in a location readily accessible to City personnel, downstream from any traps, interceptors or other pretreatment facilities, and before connection to the public sewer. Each sampling appurtenance shall be fitted with a cover that can readily be removed for sampling access.

- A. For all industrial projects the sampling appurtenance shall be a standard manhole in accordance with [Section 9.020.10](#) or a similar structure which affords an equivalent degree of access for the installation of flow monitoring and sampling equipment.
- B. For commercial projects, the sampling appurtenance shall be a minimum of a “T” of the same diameter as the private lateral except that no sampling “T” shall be less than six (6) inches in diameter. The City may, at its discretion, require a standard manhole or equivalent structure, as described above in lieu of a sampling “T” for a commercial project.

### 6. Abandonment of Sanitary Sewer Services

Sanitary sewer laterals, from buildings to be demolished, shall be cleanly cut and plugged by attaching a Fernco (or approved equal) transition coupling to the cut lateral and a plastic plug. The latera shall be plugged at the foundation wall or at the last trap leaving the building.

### 7. Private Force Main Connections

Private force lateral main connections to the public gravity sewers will only be considered where site topography does not allow for gravity lateral service to the sanitary sewer or the gravity extension of the sanitary sewer is not feasible. Make the force connection into public gravity sewer by one of the following two methods:

- b. Directly into a manhole one foot above the flowline. See [Section 9.030.09.1.B](#).
- c. Connect the private small diameter force main into a private 6-inch clean-out assembly. From the clean-out, install a 6-inch gravity lateral with a 1.1 percent

## Section 9 Sanitary Sewer Facilities

slope into the public sewer through a wye connection.

For all properties, the operation and maintenance of private grinder pumps and their pressure laterals shall be the responsibility of the property owner.

### 8. Oil/Gas Separators, Sand Interceptors, and Grease Interceptors

If required by the City, grease, oil and sand interceptors shall be provided when such devices are necessary for the proper handling of liquid wastes containing grease or oil in excessive amounts or any flammable wastes, sand, or other harmful materials which can be intercepted. Such interceptors shall not be required for private dwelling units. Prior to the installation of any interceptor, drawings and specifications shall be submitted to the City for approval. All interceptors shall be located so as to be readily accessible for cleaning and visual inspection on influent and effluent sides. All interceptors shall be properly sized, in no case shall the grease interceptor be less than 1,500 gallons, except in special cases in the Uptown District.

Grease and oil interceptors shall be constructed of impervious materials capable of withstanding sudden and extreme changes in temperature. All such devices shall be of substantial construction, water-tight, and equipped with easily removable covers which, when bolted in place, shall be gas tight and watertight, unless otherwise approved by the City.

All grease, oil and sand interceptors shall be maintained in effective operation at all times by and at the expense of the user.

## 9.040 Inspection and Testing

All projects shall be inspected and tested upon completion of installation in the presence of City staff. The City Engineer will designate the locations of test and extent of the system to be tested, and extent of recording test results. Equipment for performing tests and making measurements shall be furnished by the contractor. Sections of sewer which fail to pass the tests shall have defects located and repaired or replaced and be retested until with the specified allowance.

### 9.040.01 Manholes

All manholes shall be thoroughly cleaned of dirt and debris and all visible leakage eliminated before inspections and acceptance.

All manholes shall be tested for leakage by vacuum testing. A vacuum of ten (10) inches Hg shall be placed on the manhole and the time shall be measured for the vacuum to drop to nine (9) inches Hg. The vacuum shall not drop below nine (9) inches Hg for the time indicated for each size of manhole as shown in [Table 9.4](#).



## Section 9 Sanitary Sewer Facilities

Manhole Diameter (inches)	Max. Time for 9" Drop (seconds)
48	60
60	75
72	90
84	105

Requirements for Manhole Vacuum Testing

**Table 9.4**

Any manholes that fail the test shall be sealed and re-tested until acceptable. The testing shall be done after backfilling. Leaks found shall be fixed externally unless approved by the City Engineer. The manhole frame and adjusting rings shall be in place at finished grade prior to testing.

### 9.040.02 Flexible Pipe Testing

Prior to other test all sanitary sewer pipes shall be cleaned and inspected for major defects. Pre-cleaning by appropriately sized sewer cleaning ball or by high velocity jet or other approved method shall be performed. Any debris, grit, etc. shall be removed and shall not be allowed to enter the existing system.

#### 1. Visual Testing

The City requires that sewer lines be inspected visually to verify accuracy of alignment and freedom from debris and obstructions. The full diameter of the pipe for straight alignments shall be visible when viewed between consecutive manholes. The method of test shall be closed circuit television.

#### 2. Deflection Testing

A mandrel test is required by the City from structure to structure for all sewer lines installed. Deflection limits for flexible pipe materials shall not exceed the manufacturer's recommended deflection limit or a maximum of 5.0% of the internal diameter of the pipe, whichever is more stringent.

Where deflection is found in excess of allowable testing limits, the contractor shall excavate to the point of excess deflection and carefully compact around the point where excess deflection was found. The line shall then be retested for deflection. However, should after the initial testing the deflected pipe fail to return to the original size (inside diameter), the line shall be replaced.

#### 3. Leakage Test

After a manhole to manhole reach of pipe has been backfilled to final grade and prepared for testing, the pipe shall be air tested in accordance with "*Standard Specifications for Water and Sewer Construction in Illinois*".

## Section 10 Water Distribution Facilities

### 10.010 General

All water mains and services shall be designed and constructed to conform to these design requirements and installed by a State of Illinois Licensed Plumber. In general all proposed extensions or replacements of the City's water distribution system shall accomplish the following:

- Extend water mains through a proposed development to serve otherwise unserved abutting properties.
- Provide adequate capacity including maximum fire flows to serve all of the lots proposed to be served by the main, plus any additional extension to the main which serve future developments with the types of uses and the maximum density permitted by the Title 17 of the Collinsville Municipal Code.
- Maintain separation from public or private sewer or septic systems
- Loop water mains to avoid dead-ends

It is the responsibility of the developer to install, or have installed, the necessary water mains to serve the development. All lots in a development shall be served by a water main within fifty (50) feet of each individual lot. Whenever the existing public water sewer system is to be extended for a proposed development, the developer shall have detailed construction plans, bill of materials, and completed papers for the Environmental Protection Agency Permit prepared by a professional engineer registered in the State of Illinois. All plans shall be approved by the City Engineer prior to submittal to the Illinois Environmental Protection Agency.

### 10.020 General Requirement of Water Main Construction

#### 10.020.01 Size

The minimum size water main shall be 8-inch diameter in residential zones and 10-inch diameter in commercial, industrial and institutional zones.

Should a larger size main be required by the City to improve the overall distribution flow and to make a looped connection, the City will participate in the cost of the main on a pro-rata basis for the extra cost of the additional size.

#### 10.020.02 Materials

All water mains constructed shall be either ductile iron or plastic pipe.

All ductile iron pipe shall be cement-lined Class 50 or 52 (dependent upon site conditions) meeting the requirements of AWWA C151, with mechanical or rubber ring (slip seal or push on) joints. Corrosion protection shall be in accordance with AWWA C105, or as conditions require.

## Section 11 Commercial Site Design

All plastic pipe shall be Class 200, SDR 21 or AWWA C900, DR 18 (dependent upon site conditions) PVC pipe with joints conforming to ASTM D 3139 and F 477.

In the event PVC water main is used, it shall be necessary to install a copper tracer wire with the main to allow future underground location. The tracer wire shall be THWN soft drawn No. 12 copper and shall be connected to all valves and hydrants. All underground splices shall be made with silicone filled wire nuts.

### **10.020.03 Bedding and Backfill**

The project Plans and Project Specifications shall indicate the specific type or types of bedding or encasement required in the various parts of the water main construction if different than the current "*Standard Specifications for Water and Sewer Construction in Illinois*".

Special design and bedding provisions shall be made for pipes laid under or over fills or embankments in shallow or partial trenches either by specifying extra strength pipe for the additional loads due to differential settlement, or by special construction methods, including ninety (90%) modified proctor compaction of fill, to prevent or minimize such additional loads. Special considerations shall be made for pipe material and bedding for unsuitable soil conditions or other conditions within the project area that may affect the pipe design.

Compacted granular backfill shall be required in all trench excavation within public (or private) streets rights-of-way or area where street rights-of-way are anticipated to be dedicated for public use. Under area to be paved, the compacted granular backfill shall be placed to the subgrade of the pavement. Under unpaved areas, the compacted granular backfill shall be placed to within two (2) feet of the finished surface, and generally not more than two (2) feet beyond street pavement or curb lines. For new residential developments, in areas outside of street right-of-way, where private driveways are not yet constructed, granular backfill will not be required.

### **10.020.04 Pipe Under Streets and Pavements**

Any pipe beneath a highway, road, street or pavement, or with reasonable probability of being so located, shall have ample strength for all vertical loads, including live load required by the highway authority having jurisdiction, but in no case shall provide for less than an AASHTO HS-20 loading. Special considerations may be required for adverse conditions. Compacted granular backfill shall be utilized to the base of the pavement. For new residential site developments, in areas outside of street right-of-way, where private driveways are not yet construct, granular backfill will not be required.

### **10.020.05 Fittings and Valves**

Valves shall be installed in strategic locations to provide for subsystem isolation for any necessary future maintenance or repairs.

## Section 11 Commercial Site Design

All water main fittings and valves to be secured by use of restraint joint glands, EBBA, Model 2000 or equal. Cor-Blue nuts and bolts, or approved equal, shall be used to attach all fittings, valves, and restraint joint glands.

All valves shall be right closing, resilient wedge gate valves with integral stainless steel nuts and bolts (bonnet and packing bolts). All valves shall be in valve boxes with water lids.

All tapping sleeves shall be stainless steel sleeves with ductile iron flange, Romac Industries Model SST or approved equal. Flange bolts and nuts to be 316 stainless steel.

All water main fittings shall be mechanical joint AWWA C153 Compact Ductile Iron.

### 10.020.06 Fire Hydrants

Fire hydrants shall be installed by the developer at strategic locations. In single-family residential areas, hydrant spacing shall not exceed five hundred (500) feet. In all other zone districts, hydrant spacing shall not exceed three hundred (300) feet.

All hydrants shall be 5-1/4-inch barrel, 3-way Mueller Centurion Model A-423, Kennedy Guardian or Clow Medallion with a 3.5-foot bury, two (2) two and one-half (2½) inch discharges, a four and one-half (4½) inch steamer connection, and National Standard threads. The hydrant shall be yellow in color by the Manufacturer.

A six (6) inch resilient wedge gate valve shall be installed between two (2) and three (3) feet ahead of all hydrants. All valves shall be in valve boxes with water lids.

The hydrant shall be anchored to the gate valve by use of an anchoring coupling or restraint joint gland meeting the requirements of [Section 10.020.05](#) and attached with nuts and bolts meeting the requirements of [Section 10.020.05](#).

### 10.020.07 Location

Water mains shall have a minimum cover of forty-two (42) inches and a maximum cover of six (6) feet from the top of pipe to the finished ground surface. Any variation must be approved by the City Engineer.

Water mains are generally located on the north and east sides of the street. The preferred location is between the curb and sidewalk. Water mains parallel to curbs shall be located at least two (2) feet from the back of the curb.

Water mains shall be looped except where cul-de-sacs can be served by mains five hundred (500) feet or less in length.

Water main locations are determined primarily by the requirements of service and improving system reliability. It is also necessary to consider accessibility for construction and maintenance, site availability and competing uses, and effects of easements on private property.

## Section 11 Commercial Site Design

1. Water mains shall be constructed within the public Right-of-Way whenever possible.
2. When it is necessary to construct a water main on private property, an exclusive watermain easement shall be granted to the City of Collinsville, extending a minimum of ten (10) feet on either side of the main and shall be recorded.
3. No water main shall be laid under, nor within ten (10) feet of, any building or permanent structure.
4. Water main that connects to an existing public water main at two locations or more (looped), and/or has multiple services tapped off of it, shall be public water main.

### **10.020.09**   **Grade**

Water mains shall be laid at a uniform grade between main junctures. Where a uniform grade is not possible, the grade shall be designed so that the number of changes in the direction of the slope are the minimum possible.

1. Where both end of a section of main are at a lower elevation than an intermediate point, a means of releasing entrapped air (e.g. fire hydrant, air release valve) must be provided at the top of the “hill”.
2. Where both ends of the section of main are at a higher elevation than an intermediate point, a means of flushing out sediment through a fire hydrant must be provided at the bottom of the “valley”.

The minimum radii curves which may be laid by deflecting twenty (20) foot lengths of push-on joint pipe at the joints are two-hundred thirty (230) feet for pipes with a diameter of up to twelve (12) inches and three-hundred eighty (380) feet for pipes with a diameter greater than twelve (12) inches.

1. Curve radii shall be measured in the plane of defined by the centerline of the pipe.
2. Curves with smaller radii than permitted above shall be made using bends and offsets.

### **10.020.10**   **Protection of Water Supply**

No water main shall pass through or come into contact with any part of a sewer manhole or storm sewer inlet structure.

Horizontal and vertical separation between water mains, water appurtenances and all storm and sanitary sewers, and appurtenances, or other sewerage structures shall be as follows:

Outer limit of water main shall be at least ten (10) feet horizontally from outer limit of

## Section 11 Commercial Site Design

any existing or proposed sewer. Water mains and sewers shall be placed in separate trenches. If this is not possible, the water main shall be placed on an undisturbed earth shelf, the bottom of the water main shall be at least 18 inches above the top of the sewer, and the sewer must be constructed of slip-on or mechanical joint pipe or continuously encased and pressure tested to 150 psi to assure watertightness.

On crossings, a minimum of vertical clearance of eighteen (18) inches shall be provided between the outside of the water main and outside of the sanitary sewer. Sewer pipe joints shall be equidistant and as far as possible from the water main joints. Where a water main crosses under a sewer, adequate structural support shall be provided for the sewer to maintain line and grade as directed by the City Engineer.

If it is not possible to obtain proper horizontal and vertical separation, either:

1. The sewer shall be designed and constructed of equal to water pipe and pressure tested to assure water tightness prior to backfilling, or
2. Water main or sewer line is continuously encased or enclosed in a watertight carrier pipe of approved material which extends 10 feet in both directions, measured perpendicular to the water main.

### **10.020.11 Dead Ends**

All dead ends on newly laid mains shall be closed with ductile iron plugs and caps. Where a dead end is not equipped with a fire hydrant, the last pipe shall be fitted with a bleeder plug and valve.

In order to reduce cost and allow future main extension to be made without interruption of water service, extensions should, where possible, end one (1) pipe length beyond a control valve. The stub end must be capped or plugged but the bleeder valve may be located in the control valve vault, provided no service connections are made to the stub.

### **10.020.12 Thrust Blocking**

The parameters involved in the design of thrust blocks shall include pipe size, maximum system pressure, angle of the bend (configuration of the fitting) and the horizontal bearing strength of the soil. Bearing surface should be placed against undisturbed soil, where possible. Where it is not possible, the fill between the bearing surface and undisturbed soil must be compacted to 90% Standard Proctor density.

Thrust blocks shall be used wherever there is a fitting installed on any pipe that is not joint restrained.

## Section 11 Commercial Site Design

Thrust blocks shall be Portland cement concrete that is a minimum of twelve (12) inches thick, formed between the pipe, or fitting, and the undisturbed trench wall. It shall be anchored in such a manner that the pipe and fitting joints will be accessible for repairs.

### 10.020.13 Service Connections

Every property with frontage along a water main and having a habitable dwelling shall be provided a water service to the property line when the main is constructed, unless the property has an existing service connection to another main along which the property fronts. Every property shall have a separate service connection to the water main, and no more than one property shall be served by any one connection to a main.

The City will provide the water meter, lid and cover, and meter tile.

All water meter lids and valve boxes to be adjusted to the proper finish grade.

### 10.020.14 Hydrostatic Testing

After the pipe has been laid and partly backfilled as specified, all newly laid pipe or any valved sections of it shall, unless otherwise expressly specified, be subjected to a hydrostatic pressure equal to fifty (50) percent more than the operating pressure at the lowest elevation of the pipe section, but not to exceed the pressure rating of the type of pipe specified. The duration of each pressure test shall be for a period of not less than one hour and not more than six hours. The basic provisions of AWWA C600 and C605 shall be applicable. All pressure testing shall be done in the presence of City staff.

After test pressure has been reached and the system allowed to stabilize, not more than plus or minus five pounds per square inch gauge ( $\pm 5$  PSIG) deviation will be allowed for the duration of the test.

All exposed pipe, fittings, valves, hydrants and joints shall be carefully examined. All joints showing visible leaks shall be repaired by the contractor. Any cracked or defective pipe, fittings, valves, or hydrants discovered in consequence of the pressure test shall be removed and replaced by the contractor. The test shall be repeated until satisfactory to the City.

A leakage test shall be conducted if the pressure test can not be satisfactorily completed. Leakage shall be defined as the quantity of water that must be supplied into the newly laid pipe, or any valved sections thereof, to maintain pressure within five pounds per square inch (5 PSI). Leakage shall not be measured by a drop in pressure in a test section over a period of time.

No pipe installation will be accepted if the leakage is greater than specified in AWWA Standard C600-87, which is determined by the following formula:

$$L = \frac{SD\sqrt{P}}{132,2000}$$

## Section 11 Commercial Site Design

Where,

L = testing (leakage) allowance (makeup water), in gallons per hour

S = length of pipe tested, in feet

D = nominal diameter of pipe, in inches

P = average test pressure during the hydrostatic test, in pounds per square inch (gauge)

### **10.020.15 Disinfection**

After the backfill has been completely made, the contractor shall disinfect the pipeline in compliance with the provisions of AWWA Standard C651.

Following disinfection, City staff shall flush the watermain that was tested and collect bacteriological testing samples.